

श्रव्य, वीडियो एवं समान इलेक्ट्रॉनिकी  
उपकरण — सुरक्षा अपेक्षाएँ  
( पाँचवा पुनरीक्षण )

Audio, Video and Similar Electronic  
Apparatus — Safety Requirements  
( Fifth Revision )

ICS 97.020

FOR BIS INTERNAL USE. TO BE  
USED FOR STANDARDS  
DEVELOPMENT PURPOSE ONLY

© BIS 2017



भारतीय मानक ब्यूरो  
BUREAU OF INDIAN STANDARDS  
मानक भवन, 9 बहादुरशाह ज़फर मार्ग, नई दिल्ली-110002  
MANAK BHAVAN, 9 BAHADUR SHAH ZAFAR MARG  
NEW DELHI-110002  
[www.bis.gov.in](http://www.bis.gov.in) [www.standardsbis.in](http://www.standardsbis.in)



## CONTENTS

NATIONAL FOREWORD.....	iv
INTRODUCTION.....	x
1 General .....	1
2 Terms and definitions.....	6
3 General requirements .....	19
4 General test conditions .....	19
5 Marking and instructions .....	24
6 Hazardous radiations .....	30
7 Heating under normal operating conditions.....	32
8 Constructional requirements with regard to the protection against electric shock.....	36
9 Electric shock hazard under normal operating conditions.....	44
10 Insulation requirements.....	48
11 Fault conditions .....	51
12 Mechanical strength.....	55
13 CLEARANCES and CREEPAGE DISTANCES .....	61
14 Components .....	75
15 TERMINALS .....	91
16 External flexible cords.....	98
17 Electrical connections and mechanical fixings .....	100
18 Mechanical strength of picture tubes and protection against the effects of implosion.....	103
19 Stability and mechanical hazards .....	104
20 Resistance to fire.....	107
Annex A (normative) Additional requirements for apparatus with protection against splashing water.....	123
Annex B (normative) Apparatus to be connected to the TELECOMMUNICATION NETWORKS .....	124
Annex C (normative) Band-pass filter for wide-band noise measurement .....	126
Annex D (normative) Measuring network for TOUCH CURRENTS.....	127
Annex E (normative) Measurement of CLEARANCES and CREEPAGE DISTANCES.....	128
Annex F (normative) Table of electrochemical potentials .....	132
Annex G (normative) Flammability test methods .....	133
Annex H (normative) Insulated winding wires for use without interleaved insulation (see 8.16) .....	136
Annex I (Void) .....	139
Annex J (normative) Alternative method for determining minimum CLEARANCES.....	140
Annex K (normative) Impulse test generators (see 13.3.4 and Annex J, Clause J.6).....	145
Annex L (normative) Additional requirements for electronic flash apparatus for photographic purposes .....	146
Annex M (informative) Examples of requirements for quality control programmes for allowing reduced clearances.....	150
Annex N (informative) Routine tests .....	151
Bibliography .....	154

Figure 1 – Test circuit for fault conditions .....	111
Figure 2 – Example of an assessment of REINFORCED INSULATION.....	111
Figure 3 – Example of ACCESSIBLE parts .....	112
Figure 4 – Test hook .....	113
Figure 5 – Surge test.....	114
Figure 6 – Dielectric strength test instrument.....	115
Figure 7 – Test voltages.....	116
Figure 8 – Impact test using a steel ball.....	116
Figure 9 – Test plug for mechanical tests on antenna coaxial sockets.....	117
Figure 10 – Minimum CLEARANCES and CREEPAGE DISTANCES ON PRINTED BOARDS .....	118
Figure 11 – Test apparatus for devices forming a part of the MAINS plug .....	119
Figure 12 – Scratch patterns for implosion test .....	120
Figure 13 – Distances from a POTENTIAL IGNITION SOURCE and an example for the design of barriers .....	120
Figure 14 – Mandrel .....	121
Figure 15 – Initial position of mandrel .....	121
Figure 16 – Final position of mandrel.....	121
Figure 17 – Position of metal foil on insulating material.....	122
Figure C.1 – Band-pass filter for wide-band noise measurement (amplitude/frequency response limits).....	126
Figure D.1 – Measuring network for TOUCH CURRENTS according to IEC 60990 .....	127
Figure E.1 – Narrow groove.....	128
Figure E.2 – Wide groove.....	129
Figure E.3 – V-shaped groove .....	129
Figure E.4 – Rib.....	129
Figure E.5 – Uncemented joint with narrow groove .....	129
Figure E.6 – Uncemented joint with wide groove.....	130
Figure E.7 – Uncemented joint with narrow and wide grooves .....	130
Figure E.8 – Intervening, unconnected conductive part .....	130
Figure E.9 – Narrow recess .....	131
Figure E.10 – Wide recess .....	131
Figure K.1 – Impulse generating circuit.....	145
Table 1 – Voltage ranges of TNV-CIRCUITS.....	11
Table 2 – Test power supply.....	21
Table 3 – Permissible temperature rise of parts of the apparatus (1 of 2).....	34
Table 4 – Test temperature and testing time (in days) per cycle .....	42
Table 5 – Test voltages for dielectric strength test and values for insulation resistance .....	51
Table 6 – Impact test on the enclosure of apparatus .....	56
Table 7 – Torque values for end-piece test.....	59
Table 8 – Minimum CLEARANCES for insulation in circuits CONDUCTIVELY CONNECTED TO THE MAINS and between such circuits and circuits not CONDUCTIVELY CONNECTED TO THE MAINS .....	65

Table 9 – Additional CLEARANCES for insulation in circuits CONDUCTIVELY CONNECTED TO THE MAINS with peak WORKING VOLTAGES exceeding the peak value of the nominal a.c. MAINS voltage and between such circuits and circuits not CONDUCTIVELY CONNECTED TO THE MAINS .....	66
Table 10 – Minimum CLEARANCES in circuits not CONDUCTIVELY CONNECTED TO THE MAINS.....	68
Table 11 – Minimum CREEPAGE DISTANCES .....	71
Table 12 – Minimum CLEARANCES and CREEPAGE DISTANCES (enclosed, enveloped or hermetically sealed constructions) .....	74
Table 13 – Flammability category related to distance from POTENTIAL IGNITION SOURCES .....	77
Table 14 – Peak surge current .....	87
Table 15 – Nominal cross-sectional area to be accepted by TERMINALS .....	95
Table 16 – Minimum nominal thread diameter.....	95
Table 17 – Pull force on pins .....	97
Table 18 – Nominal cross-sectional areas of external flexible cords .....	98
Table 19 – Mass and pulley diameter for stress test.....	99
Table 20 – Torque to be applied to screws.....	101
Table 21 – Distances from POTENTIAL IGNITION SOURCES and consequential flammability categories .....	110
Table B.1 – Separation of TNV circuits .....	125
Table E.1 – Value of $X$ .....	128
Table H.1 – Mandrel diameter .....	136
Table H.2 – Oven temperature .....	137
Table J.1 – MAINS transient voltages .....	141
Table J.2 – Minimum CLEARANCES .....	144
Table K.1 – Component values for impulse generating circuits.....	145
Table M.1 – Rules for sampling and inspection – Reduced CLEARANCES.....	150
Table N.1 – Test voltage .....	153

## NATIONAL FOREWORD

This Indian Standard (Fifth Revision) which is identical with IEC 60065 : 2014 'Audio, video and similar electronic apparatus — Safety requirements' issued by the International Electrotechnical Commission (IEC) was adopted by the Bureau of Indian Standards on the recommendation of the Audio, Video and Multimedia Systems and Equipments Sectional Committee and approval of the Electronics and Information Technology Division Council.

This standard was first published in 1957 and subsequently revised in 1981, 1986, 2003 and 2010. The fifth revision of this standard is being done to bring it in line with the latest edition of IEC 60065 : 2014.

The text of IEC Standard has been approved as suitable for publication as an Indian Standard without deviations. Certain conventions are however not identical to those used in Indian Standards. Attention is particularly drawn to the following:

- a) Wherever the words 'International Standard' appear referring to this standard, they should be read as 'Indian Standard'.
- b) Comma (,) has been used as a decimal marker while in Indian Standards, the current practice is to use a point (.) as the decimal marker.

In this adopted standard, reference appears to certain International Standards for which Indian Standards also exist. The corresponding Indian Standards, which are to be substituted in their places, are listed below along with their degree of equivalence for the editions indicated:

<i>International Standard</i>	<i>Corresponding Indian Standard</i>	<i>Degree of Equivalence</i>
IEC 60027 (All parts) Letter symbols to be used in electrical technology	IS 3722 Letter symbols and signs used in electrical technology : (Part 1) : 1983 General guidance on symbols and subscripts (Part 2) : 1983 Reference tables for symbols and subscripts	Technically Equivalent
IEC 60068-2-6 : 2007 Environmental testing — Part 2-6: Tests — Test Fc: Vibration (sinusoidal)	IS 9001 (Part 13) : 1981 Guidance for environmental testing: Part 13 vibration (sinusoidal) test	do
IEC 60068-2-75 Environmental testing — Part 2-75 : Tests — Test Eh: Hammer tests	IS 9000 (Part 7/Sec 7) : 2006 Basic environmental testing procedures for electronic and electrical items: Part 7 Impact test, Section 7 Test Eh : Hammer tests	Identical with IEC 60068-2-75 : 1997
IEC 60068-2-78 Environmental testing — Part 2: Tests — Test Cab: Damp heat, steady state	IS 9000 (Part 4) : 2008 Basic environmental testing procedures for electronic and electrical items: Part 4 Damp heat (steady state) ( <i>first revision</i> )	Identical with IEC 60068-2-78 : 2001
IEC 60085 Electrical insulation — Thermal evaluation and designation	IS 1271 : 2012 Electrical insulation-thermal evaluation and designation ( <i>second revision</i> )	Identical with IEC 60085 : 2007
IEC 60086-4 Primary batteries — Part 4 : Safety of lithium batteries	IS 6303 (Part 4) : 2013 Primary batteries: Part 4 Safety of lithium batteries ( <i>second revision</i> )	Identical with IEC 60086-4 : 2007

<i>International Standard</i>	<i>Corresponding Indian Standard</i>	<i>Degree of Equivalence</i>
IEC 60107-1 : 1997 Methods of measurement on receivers for television broadcast transmissions — Part 1: General considerations — Measurements at radio and video frequencies	IS 4545 (Part 1) : 2008 Methods of measurement on receivers for television broadcast transmissions: Part 1 General considerations ( <i>second revision</i> )	Technically Equivalent
IEC 60112 Method for the determination of the proof and the comparative tracking indices of solid insulating materials	IS 2824 : 2007 Method for determining of the proof and the comparative tracking indices of solid insulating materials ( <i>second revision</i> )	Identical with IEC 60112 : 2003
IEC 60127 (All parts) Miniature fuses	IS/IEC 60127 (All parts) Miniature fuses ( <i>first revision</i> )	Identical
IEC 60127-6 Miniature fuses — Part 6: Fuse-holders for miniature cartridge fuse-links	IS/IEC 127-6 : Miniature fuses: Part 6 Fuse-holders for miniature cartridge fuse-links — Specification	Identical with IEC 60127-6 : 1994
IEC 60167 : 1964 Methods of test for the determination of the insulation resistance of solid insulating materials	IS 2259 : 1963 Methods of test for determination of insulation resistance of solid insulating materials	Technically Equivalent
IEC 60216 (All parts) Electrical insulating materials — Thermal endurance properties	IS 8504 (All parts) Electrical insulating materials — Thermal endurance properties	Identical
IEC 60227 (All parts) Polyvinyl chloride insulated cables of rated voltages up to and including 450/750 V	IS 694 : 2010 Polyvinyl chloride insulated unsheathed and sheathed cables/cords with rigid and flexible conductor for rated voltages up to and including 450/750 V	Technically Equivalent
IEC 60245 (All parts) Rubber insulated cables — Rated voltages up to and including 450/750 V	IS 9968 Elastomer insulated cables: (Part 1) : 1998 For working voltages up to and including 1100 V ( <i>first revision</i> ) (Part 2) : 2002 For working voltages from 3.3 kV up to and including 3 kV ( <i>first revision</i> )	do
IEC 60268-1 : 1985 Sound system equipment — Part 1: General	IS 15596 (Part 1) : 2005 Sound system equipment: Part 1 General	Identical
IEC 60317-43 Specifications for particular types of winding wires — Part 43: Aromatic polyimide type wrapped round copper wire, class 240	IS 13730 (Part 43) : 2013 Specifications for particular types of winding wires: Part 43 Aromatic polyimide type wrapped round copper wire, class 240 ( <i>first revision</i> )	Identical with IEC 60317-43 : 2010
IEC 60320 (All parts) Appliance couplers for household and similar general purposes	IS/IEC 60320 (All parts) Appliance couplers for household and similar general purposes	Identical
IEC 60320-1 Appliance couplers for household and similar general purposes — Part 1: General requirements	IS/IEC 60320-1 : 2001 Appliance couplers for household and similar general purposes: Part 1 General requirements	Identical with IEC 60320-1 : 2001
IEC 60335-1 Household and similar electrical appliances — Safety — Part 1: General requirements	IS 302 (Part 1) : 2008 Safety of household and similar electrical appliances: Part 1 General requirements ( <i>sixth revision</i> )	Technically Equivalent

**IS 616 : 2017**  
**IEC 60065 : 2014**

<i>International Standard</i>	<i>Corresponding Indian Standard</i>	<i>Degree of Equivalence</i>
IEC 60384-1 : 2008 Fixed capacitors for use in electronic equipment — Part 1: Generic specification	IS 7305 : 1984 Fixed capacitors used in electronic equipment ( <i>first revision</i> )	Technically Equivalent
IEC 60384-14 : 2005 Fixed capacitors for use in electronic equipment — Part 14 : Sectional specification: Fixed capacitors for electromagnetic interference suppression and connection to the supply mains	IS QC 302400 : 1994 Fixed capacitors for use in electronic equipment: Part 14 Sectional specification : Fixed capacitors for electromagnetic interference suppression and connection to the supply mains supply mains	Identical with IEC Pub 384-14/QC 302400 (1993-07)
IEC 60410 : 1973 Sampling plans and procedures for inspection by attributes	IS 10373 : 1983 Sampling plan and procedures for inspection by attributes for electronic items	Technically Equivalent
IEC 60417 Graphical symbols for use on equipment	IS 2032 (All parts) Graphical symbols used in electro technology	do
IEC 60454 (All parts) Pressure-sensitive adhesive tapes for electrical purposes	IS 7809 (All parts) Specification for pressure sensitive adhesive insulating tapes for electrical purposes	do
IEC 60529 : 1989 Degrees of protection provided by enclosures (IP code)	IS/IEC 60529 : 2001 Degrees of protection provided by enclosures (IP code)	Identical with IEC 60529 : 2001
IEC 60664-1 : 2007 Insulation coordination for equipment within low-voltage systems — Part 1: Principles, requirements and tests	IS 15382 (Part 1) : 2014 Insulation coordination for equipment within low-voltage systems: Part 1 Principles, requirements and tests ( <i>first revision</i> )	Identical
IEC 60664-3 Insulation coordination for equipment within low-voltage systems — Part 3 : Use of coating, potting or moulding for protection against pollution	IS 15382 (Part 3) : 2006 Insulation coordination for equipment within low-voltage systems: Part 3 Use of coating, potting or moulding for protection against pollution	Identical with IEC 60664-3 : 2003
IEC 60691 : 2002 Thermal links — Requirements and application guide	IS/IEC 691 : 1993 Thermal links — Requirements and application guide	Identical with IEC Pub 691 : 1993
IEC 60695-11-5 : 2004 Fire hazard testing — Part 11-5: Test flames — Needle-flame test method — Apparatus, confirmatory test arrangement and guidance	IS 11000 (Part 2/Sec 2) : 2008 Fire hazard testing : Part 2 Test methods — Section 2 Needle-flame test method — Apparatus confirmatory test arrangement and guidance ( <i>first revision</i> )	Identical
IEC 60730-1 : 2010 Automatic electrical controls for household and similar use — Part 1: General requirements	IS/IEC 60730-1 : 1999 Automatic electric controls for household and similar use: Part 1 General requirements	Identical with IEC 60730 : 1999
IEC 60747-5-5 : 2007 Semiconductor devices — Discrete devices — Part 5-5: Optoelectronic devices — Photocouplers	IS 14901 (Part 5) : 2004 Semiconductor devices — Discrete devices and integrated circuits: Part 5 Optoelectronic devices	Identical with IEC 60747-5 : 1992
IEC 60851-3 : 2009 Winding wires — Test methods — Part 3: Mechanical properties	IS 13778 (Part 3) : 2012 Winding wires — Test methods: Part 3 Mechanical properties	Identical
IEC 60851-5 : 2008 Winding wires — Test methods — Part 5: Electrical properties	IS 13778 (Part 5) : 2012 Winding wires — Test methods: Part 5 Electrical properties	do

<i>International Standard</i>	<i>Corresponding Indian Standard</i>	<i>Degree of Equivalence</i>
IEC 60851-6 : 2012 Winding wires — Test methods — Part 6: Thermal properties	IS 13778 (Part 6) : 2011 Winding wires — Test methods: Part 6 Thermal properties	Identical with IEC 60851-6 : 1996
IEC 60906 (All parts) IEC system of plugs and socket-outlets for household and similar purposes	IS 1293 : 2005 Plugs and socket-outlets of rated voltage up to and including 250 volts and rated current up to and including 16 amperes — Specification ( <i>third revision</i> )	Technically Equivalent
IEC 60950-1 : 2005 Information technology equipment — Safety — Part 1: General requirements	IS 13252 (Part 1) : 2010 Information technology equipment — Safety: Part 1 General requirements	Identical
IEC 60990 Methods of measurement of touch current and protective conductor current	IS/IEC 60990 : 1999 Methods of measurement of touch current and protective conductor current	Identical with IEC 60990 : 1999
IEC 61032 : 1997 Protection of persons and equipment by enclosures — Probes for verification	IS 1401 : 2008 Protection of persons and equipment by enclosures — Probes for verification ( <i>second revision</i> )	Identical
IEC 61051-2 : 1991 Varistors for use in electronic equipment — Part 2: Sectional specification for surge suppression varistors	IS QC 420100 : 1994 Varistors for use in electronic equipment — Sectional specification for surge suppression varistors	do
IEC 61058-1 : 2000 Switches for appliances — Part 1: General requirements	IS/IEC 61058-1 : 2000 Switches for appliances: Part 1 General requirements	do
IEC 61260 Electroacoustics — Octave-band and fractional-octave-band filters	IS 6964 : 2001 Electroacoustics — Octave-band and fractional-octave-band filters ( <i>first revision</i> )	Identical with IEC 61260 : 1995
IEC 61558-1 : 2005 Safety of power transformers, power supplies, reactors and similar products — Part 1: General requirements and tests	IS/IEC 61558-1 : 1997 Safety of power transformers, power supply units and similar: Part 1 General requirements and tests	Identical with IEC 61558-1 : 1997
IEC 61965 Mechanical safety of cathode ray tubes	IS/IEC 61965 : 2003 Mechanical safety of cathode ray tubes	Identical with IEC 61965 : 2003
IEC 62133 Secondary cells and batteries containing alkaline or other non-acid electrolytes — Safety requirements for portable sealed secondary cells, and for batteries made from them, for use in portable applications	IS 16046 : 2012 Secondary cells and batteries containing alkaline or other non-acid electrolytes — Safety requirements for portable sealed secondary cells, and for batteries made from them, for use in portable applications	Identical with IEC 62133 : 2002
IEC 62151 : 2000 Safety of equipment electrically connected to a telecommunication network	IS 16423 : 2016 Safety of equipment electrically connected to a telecommunication network	Identical
IEC 62471 : 2006 Photobiological safety of lamps and lamp systems	IS 16108 : 2012 Photobiological safety of lamps and lamp systems	do
ISO 261 ISO general purpose metric screw threads — General plan	IS 4218 (Part 2) : 2001 ISO general purpose metric screw threads : Part 2 General plan ( <i>second revision</i> )	Identical with ISO 261 : 1998
ISO 262 ISO general-purpose metric screw threads — Selected sizes for screws, bolts and nuts	IS 4218 (Part 4) : 2001 ISO general purpose metric screw threads: Part 2 Selected sizes for screws, bolts and nuts ( <i>second revision</i> )	Identical with ISO 262 : 1998

**IS 616 : 2017**  
**IEC 60065 : 2014**

<i>International Standard</i>	<i>Corresponding Indian Standard</i>	<i>Degree of Equivalence</i>
ISO 306 : 2004 Plastics — Thermoplastic materials — Determination of Vicat softening temperature (VST)	IS 13360 (Part 6/Sec 1) : 1999 Plastics — Methods of testing: Part 6 Thermal properties, Section 1 Determination of vicat softening temperature of thermoplastic materials ( <i>first revision</i> )	Identical
ISO 2859-1 : 1999 Sampling procedures for inspection by attributes — Part 1: Samplingschemes indexed by acceptance quality level (AQL) for lot-by-lot inspection	IS 2500 (Part 6) : 2014 Sampling procedures for inspection by attributes: Part 6 System of sequential sampling plans indexed by acceptance quality limit (AQL) for lot-by-lot inspection	do
ISO 9773 Plastics — Determination of burning behaviour of thin flexible vertical specimens incontact with a small-flame ignition source	IS 13360 (Part 6/Sec 23) : 2006 Plastics — Methods of testing: Part 6 Thermal properties, Section 23 Determination of burning behaviour of thin flexible vertical specimens in contact with small-flame ignition Source	Identical with ISO 9773 : 1998

The technical committee has reviewed the provisions of following International Standards referred in this adopted standard and has decided that theyare acceptable for use in conjunction with this standard:

<i>International Standard</i>	<i>Title</i>
IEC 60038 : 2009	IEC standard voltages
IEC 60068-2-31 : 2008	Environmental testing — Part 2-31: Tests — Test Ec : Rough handling shocks, primarily for equipment-type specimens
IEC 60227-2 : 1997	Polyvinyl chloride insulated cables of rated voltages up to and including 450/750 V — Part 2: Test methods
IEC 60249-2 (All parts)	Base materials for printed circuits — Part 2: Specifications
IEC 60695-11-10 : 2013	Fire hazard testing — Part 11-10: Test flames — 50 W horizontal andvertical flame test methods
IEC 60825-1 : 2007	Safety of laser products — Part 1: Equipment classification and requirements
IEC 60998-2-2	Connecting devices for low-voltage circuits for household and similar purposes — Part 2-2: Particular requirements for connecting devices as separate entities with screwless-type clamping units
IEC 60999-1	Connecting devices — Electrical copper conductors — Safety requirements for screw-type and screwless-type clamping units — Part 1: General requirements andparticular requirements for clamping units for conductors from 0,2 mm <sup>2</sup> up to 35 mm <sup>2</sup> (included)
IEC 60999-2	Connecting devices — Electrical copper conductors. Safety requirements forscrew-type and screwless-type clamping units — Part 2: Particular requirements for clampingunits for conductors above 35 mm <sup>2</sup> up to 300 mm <sup>2</sup> (included)
IEC/TS 61149	Guide for safe handling and operation of mobile radio equipment
IEC 61293	Marking of electrical equipment with ratings related to electrical supply — Safety requirements
IEC 61558-2-16	Safety of power transformers, power supply units and similar products forvoltages up to 1 100 V — Part 2-16: Particular requirements and tests for switch mode power supply units and transformers for switch mode power supply units
IEC 62368-1	Audio/video, information and communication technology equipment — Part 1:Safety requirements

<i>International Standard</i>	<i>Title</i>
IEC Guide 104	The preparation of safety publications and the use of basic safety publications and group safety publications
IEC Guide 112	Guide on the safety of multimedia equipment
ISO 7000	Graphical symbols for use on equipment — Index and synopsis
ITU-T Recommendation K.44	Resistibility tests for telecommunication equipment exposed to overvoltages and overcurrents — Basic recommendation

Only the English language text in the IEC Standard has been retained while adopting it in this Indian Standard and as such the page numbers given are not the same as in the IEC Standard.

For the purpose of deciding whether a particular requirement of this standard is complied with the final value, observed or calculated, expressing the result of a test or analysis, shall be rounded off in accordance with IS 2 : 1960 'Rules for rounding off numerical values (*revised*)'. The number of significant places retained in the rounded off value should be the same as that of the specified value in this standard.

FOR BIS INTERNAL USE. TO BE  
USED FOR STANDARDS  
DEVELOPMENT PURPOSE ONLY

## **General**

This introduction is intended to provide an appreciation of the principles on which the requirements of this standard are based. Such an understanding is essential in order that safe apparatus can be designed and manufactured.

The requirements of this standard are intended to provide protection to persons as well as to the surroundings of the apparatus.

Attention is drawn to the principle that the requirements, which are standardized, are the minimum considered necessary to establish a satisfactory level of safety.

Further development in techniques and technologies may entail the need for future modification of this standard.

NOTE The expression "protection to the surroundings of the apparatus" implies that this protection should also include protection of the natural environment in which the apparatus is intended to be used, taking into account the life cycle of the apparatus, i.e. manufacturing, use, maintenance, disposal and possible end-of-life recycling of parts of the apparatus.

## **Hazards**

The application of this standard is intended to prevent injury or damage due to the following hazards:

- electric shock;
- excessive temperatures;
- radiation;
- implosion;
- mechanical hazards;
- fire;
- chemical burns (for example, as a result of the ingestion of lithium chemistry button/coin cells).

## **Electric shock**

Electric shock is due to current passing through the human body. Currents of the order of a milliampere can cause a reaction in persons in good health and may cause secondary risks due to involuntary reaction. Higher currents can have more damaging effects. Voltages below certain limits are generally regarded as not dangerous under specified conditions. In order to provide protection against the possibility of higher voltages appearing on parts that may be touched or handled, such parts are either earthed or adequately insulated.

For parts which can be touched, two levels of protection are normally provided to prevent electric shock caused by a single fault. Thus a single fault and any consequential faults will not create a hazard. The provision of additional protective measures, such as SUPPLEMENTARY INSULATION or protective earthing, is not considered a substitute for, or a relief from, properly designed BASIC INSULATION.

### **Cause**

Contacts with parts normally at hazardous voltage.

### **Prevention**

Prevent access to parts at hazardous voltage by fixed or locked covers, interlocks, etc.

Discharge capacitors at hazardous voltages.

Breakdown of insulation between parts normally at hazardous voltage and accessible parts.

Either use double or reinforced insulation between parts normally at hazardous voltages and accessible parts so that breakdown is not likely to occur, or connect accessible conductive parts to protective earth so that the voltage which can develop is limited to a safe value. Provide adequate mechanical and electrical strength.

Breakdown of insulation between parts normally at hazardous voltage and circuits normally at non-hazardous voltages, thereby putting accessible parts and terminals at hazardous voltage.

Segregate hazardous and non-hazardous voltage circuits either by double or reinforced insulation so that breakdown is not likely to occur, or by a protective earthed screen, or connect the circuit normally at non-hazardous voltage to protective earth, so that the voltage which can develop is limited to a safe value.

Touch current from parts at hazardous voltage through the human body.

Limit touch current to a safe value or provide a protective earthing connection to the accessible parts.

(Touch current can include current due to RFI filter components connected between mains supply circuits and accessible parts or terminals.)

### **Excessive temperatures**

Requirements are included to prevent injury due to excessive temperatures of accessible parts, to prevent damaging of insulation due to excessive internal temperatures, and to prevent mechanical instability due to excessive temperatures developed inside the apparatus.

### **Radiation**

Requirements are included to prevent injury due to excessive energy levels of ionizing and laser radiation, for example by limiting the radiation to non-hazardous values.

### **Implosion**

Requirements are included to prevent injury due to implosion of picture tubes.

### **Mechanical hazards**

Requirements are included to ensure that the apparatus and its parts have adequate mechanical strength and stability, to avoid the presence of sharp edges and to provide guarding or interlocking of dangerous moving parts.

## **Fire**

A fire can result from:

- heat;
- arcing;

caused by

- overloads;
- component failure;
- insulation breakdown;
- bad connections;
- conductor breakage.

Requirements are included that are intended to prevent fire originating within the apparatus from spreading beyond the immediate vicinity of the source of the fire or from causing damage to the surroundings of the apparatus.

The following preventive measures are recommended:

- the use of suitable components and subassemblies;
- the prevention of excessive temperature rise that might cause ignition under normal or fault conditions;
- the use of measures to eliminate POTENTIAL IGNITION SOURCES such as inadequate contacts, bad connections, interruptions;
- the limitation of the quantity of combustible material used;
- the control of the position of combustible materials in relation to POTENTIAL IGNITION SOURCES;
- the use of materials with high resistance to fire in the vicinity of POTENTIAL IGNITION SOURCES;
- the use of encapsulation or barriers to limit the spread of fire within the apparatus;
- the use of suitable fire retardant materials for the enclosure.

*Indian Standard*

**AUDIO, VIDEO AND SIMILAR ELECTRONIC  
APPARATUS — SAFETY REQUIREMENTS**

*( Fifth Revision )*

**1 General**

**1.1 Scope**

**1.1.1** This International Safety Standard applies to electronic apparatus designed to be fed from the MAINS, from a SUPPLY APPARATUS, from batteries or from REMOTE POWER FEEDING and intended for reception, generation, recording or reproduction of audio, video and associated signals. It also applies to apparatus designed to be used exclusively in combination with the above-mentioned apparatus.

This standard primarily concerns apparatus intended for household and similar general use but which may also be used in places of public assembly such as schools, theatres, places of worship and the workplace. PROFESSIONAL APPARATUS intended for use as described above is also covered unless falling specifically within the scope of other standards.

This standard concerns only safety aspects of the above apparatus; it does not concern other matters, such as style or performance.

This standard applies to the above-mentioned apparatus, if designed to be connected to the TELECOMMUNICATION NETWORK or similar network, for example by means of an integrated modem.

Some examples of apparatus within the scope of this standard are:

- receiving apparatus and amplifiers for sound and/or vision;
- independent LOAD TRANSDUCERS and SOURCE TRANSDUCERS;
- SUPPLY APPARATUS intended to supply other apparatus covered by the scope of this standard;
- ELECTRONIC MUSICAL INSTRUMENTS, and electronic accessories such as rhythm generators, tone generators, music tuners and the like for use with electronic or non-electronic musical instruments;
- audio and/or video educational apparatus;
- video projectors;

NOTE 1 Film projectors, slide projectors and overhead projectors are covered by IEC 60335-2-56.

- video cameras and video monitors;
- video games and flipper games;
- juke boxes;
- electronic gaming and scoring machines;

NOTE 2 Video games, flipper games and gaming machines and other amusement games for commercial use are covered by IEC 60335-2-82.

- teletext equipment;
- record and optical disc players;
- tape and optical disc recorders;
- antenna signal converters and amplifiers;
- antenna positioners;
- Citizen's Band apparatus;

- apparatus for IMAGERY;
- electronic light effect apparatus;
- apparatus for use in alarm systems;
- intercommunication apparatus, using low voltage MAINS as the transmission medium;
- cable head-end receivers;
- professional general use amplifiers, record or disc players, tape players, recorders, and public address systems;
- professional sound/video systems;
- electronic flash apparatus for photographic purposes (see Annex L); and
- multimedia apparatus.

The requirements of IEC 60950-1 may also be used to meet the requirements for safety of multimedia apparatus (see also IEC Guide 112).

**1.1.2** This standard applies to apparatus with a RATED SUPPLY VOLTAGE not exceeding

- 250 V a.c. single phase or d.c. supply;
- 433 V a.c. in the case of apparatus for connection to a supply other than single-phase.

**1.1.3** This standard applies to apparatus for use at altitudes not exceeding 2 000 m above sea level, primarily in dry locations and in regions with moderate or tropical climates.

For apparatus with protection against splashing water, additional requirements are given in Annex A.

For apparatus to be connected to TELECOMMUNICATION NETWORKS, additional requirements are given in Annex B.

For apparatus intended to be used in vehicles, ships or aircraft, or at altitudes exceeding 2 000 m above sea level, additional requirements may be necessary.

NOTE 1 See Table A.2 of IEC 60664-1:2007.

NOTE 2 China has special requirement in choosing multiplication factors at altitude above 2 000 m.

Requirements, additional to those specified in this standard, may be necessary for apparatus intended for special conditions of use.

**1.1.4** For apparatus designed to be fed from the MAINS, this standard applies to apparatus intended to be connected to a MAINS supply with transient overvoltages not exceeding overvoltage category II according to IEC 60664-1.

For apparatus subject to transient overvoltages exceeding those for overvoltage category II, additional protection may be necessary in the MAINS supply of the apparatus.

## **1.2 Normative references**

The following documents, in whole or in part, are normatively referenced in this document and are indispensable for its application. For dated references, only the edition cited applies. For undated references, the latest edition of the referenced document (including any amendments) applies.

IEC 60027 (all parts), *Letter symbols to be used in electrical technology*

IEC 60038:2009, *IEC standard voltages*

- IEC 60068-2-6:2007, *Environmental testing – Part 2-6: Tests – Test Fc: Vibration (sinusoidal)*
- IEC 60068-2-31:2008, *Environmental testing - Part 2-31: Tests - Test Ec: Rough handling shocks, primarily for equipment-type specimens*
- IEC 60068-2-75, *Environmental testing – Part 2-75: Tests – Test Eh: Hammer tests*
- IEC 60068-2-78, *Environmental testing – Part 2-78: Tests – Test Cab: Damp heat, steady state*
- IEC 60085, *Electrical insulation – Thermal evaluation and designation*
- IEC 60086-4, *Primary batteries – Part 4: Safety of lithium batteries*
- IEC 60107-1:1997, *Methods of measurement on receivers for television broadcast transmissions – Part 1: General considerations – Measurements at radio and video frequencies*
- IEC 60112, *Method for the determination of the proof and the comparative tracking indices of solid insulating materials*  
Amendment 1:2009
- IEC 60127 (all parts), *Miniature fuses*
- IEC 60127-6, *Miniature fuses. Part 6: Fuse-holders for miniature cartridge fuse-links*
- IEC 60167:1964, *Methods of test for the determination of the insulation resistance of solid insulating materials*
- IEC 60216 (all parts), *Electrical insulating materials – Thermal endurance properties*
- IEC 60227 (all parts), *Polyvinyl chloride insulated cables of rated voltages up to and including 450/750 V*
- IEC 60227-2:1997, *Polyvinyl chloride insulated cables of rated voltages up to and including 450/750 V – Part 2: Test methods*
- IEC 60245 (all parts), *Rubber insulated cables – Rated voltages up to and including 450/750 V*
- IEC 60249-2 (all parts), *Base materials for printed circuits – Part 2: Specifications*
- IEC 60268-1:1985, *Sound system equipment – Part 1: General*
- IEC 60317-43, *Specifications for particular types of winding wires – Part 43: Aromatic polyimide type wrapped round copper wire, class 240*
- IEC 60320 (all parts), *Appliance couplers for household and similar general purposes*
- IEC 60320-1, *Appliance couplers for household and similar general purposes – Part 1: General requirements*
- IEC 60335-1, *Household and similar electrical appliances – Safety – Part 1: General requirements*
- IEC 60384-1:2008, *Fixed capacitors for use in electronic equipment – Part 1: Generic specification*

**IS 616 : 2017**  
**IEC 60065 : 2014**

IEC 60384-14:2005, *Fixed capacitors for use in electronic equipment – Part 14: Sectional specification: Fixed capacitors for electromagnetic interference suppression and connection to the supply mains*

IEC 60410:1973, *Sampling plans and procedures for inspection by attributes*

IEC 60417, *Graphical symbols for use on equipment*, available from: <<http://www.graphical-symbols.info/equipment>>

IEC 60454 (all parts), *Pressure-sensitive adhesive tapes for electrical purposes*

IEC 60529:1989, *Degrees of protection provided by enclosures (IP Code)*

IEC 60664-1:2007, *Insulation coordination for equipment within low-voltage systems – Part 1: Principles, requirements and tests*

IEC 60664-3, *Insulation coordination for equipment within low-voltage systems – Part 3: Use of coating, potting or moulding for protection against pollution*

IEC 60691:2002, *Thermal links – Requirements and application guide*

IEC 60695-11-5:2004, *Fire hazard testing – Part 11-5: Test flames – Needle-flame test method – Apparatus, confirmatory test arrangement and guidance*

IEC 60695-11-10:2013, *Fire hazard testing – Part 11-10: Test flames – 50 W horizontal and vertical flame test methods*

IEC 60730-1:2010, *Automatic electrical controls for household and similar use – Part 1: General requirements*

IEC 60747-5-5:2007, *Semiconductor devices – Discrete devices – Part 5-5: Optoelectronic devices – Photocouplers*  
Amendment 1:2013

IEC 60825-1:2007, *Safety of laser products – Part 1: Equipment classification and requirements*

IEC 60851-3:2009, *Winding wires – Test methods – Part 3: Mechanical properties*

IEC 60851-5:2008, *Winding wires – Test methods – Part 5: Electrical properties*

IEC 60851-6:2012, *Winding wires – Test methods – Part 6: Thermal properties*

IEC 60906 (all parts), *IEC system of plugs and socket-outlets for household and similar purposes*

IEC 60950-1:2005, *Information technology equipment – Safety – Part 1: General requirements*  
Amendment 1:2009  
Amendment 2:2013<sup>1</sup>

IEC 60990, *Methods of measurement of touch current and protective conductor current*

---

<sup>1</sup> A consolidated edition (2.2) exists, that includes IEC 60950-1:2005 and its Amendments 1:2009 and 2:2013.

IEC 60998-2-2, *Connecting devices for low-voltage circuits for household and similar purposes – Part 2-2: Particular requirements for connecting devices as separate entities with screwless-type clamping units*

IEC 60999-1, *Connecting devices – Electrical copper conductors – Safety requirements for screw-type and screwless-type clamping units – Part 1: General requirements and particular requirements for clamping units for conductors from 0,2 mm<sup>2</sup> up to 35 mm<sup>2</sup> (included)*

IEC 60999-2, *Connecting devices – Electrical copper conductors. Safety requirements for screw-type and screwless-type clamping units – Part 2: Particular requirements for clamping units for conductors above 35 mm<sup>2</sup> up to 300 mm<sup>2</sup> (included)*

IEC 61032:1997, *Protection of persons and equipment by enclosures – Probes for verification*

IEC 61051-2:1991, *Varistors for use in electronic equipment – Part 2: Sectional specification for surge suppression varistors*  
Amendment 1:2009

IEC 61058-1:2000, *Switches for appliances – Part 1: General requirements*

IEC/TS 61149, *Guide for safe handling and operation of mobile radio equipment*

IEC 61260, *Electroacoustics – Octave-band and fractional-octave-band filters*

IEC 61293, *Marking of electrical equipment with ratings related to electrical supply – Safety requirements*

IEC 61558-1:2005, *Safety of power transformers, power supplies, reactors and similar products – Part 1: General requirements and tests*  
Amendment 1:2009<sup>2</sup>

IEC 61558-2-16, *Safety of power transformers, power supply units and similar products for voltages up to 1 100 V – Part 2-16: Particular requirements and tests for switch mode power supply units and transformers for switch mode power supply units*

IEC 61965, *Mechanical safety of cathode ray tubes*

IEC 62133, *Secondary cells and batteries containing alkaline or other non-acid electrolytes – Safety requirements for portable sealed secondary cells, and for batteries made from them, for use in portable applications*

IEC 62151:2000, *Safety of equipment electrically connected to a telecommunication network*

IEC 62368-1, *Audio/video, information and communication technology equipment – Part 1: Safety requirements*

IEC 62471:2006, *Photobiological safety of lamps and lamp systems*

IEC Guide 104, *The preparation of safety publications and the use of basic safety publications and group safety publications*

IEC Guide 112, *Guide on the safety of multimedia equipment*

---

<sup>2</sup> A consolidated edition (2.1) exists, that includes IEC 61558-1:2005 and its Amendment 1:2009.

ISO 261, *ISO general purpose metric screw threads – General plan*

ISO 262, *ISO general-purpose metric screw threads – Selected sizes for screws, bolts and nuts*

ISO 306:2004, *Plastics – Thermoplastic materials – Determination of Vicat softening temperature (VST)*

ISO 2859-1:1999, *Sampling procedures for inspection by attributes – Part 1: Sampling schemes indexed by acceptance quality level (AQL) for lot-by-lot inspection*

ISO 7000, *Graphical symbols for use on equipment – Index and synopsis*, available from:  
<<http://www.graphical-symbols.info/equipment>>

ISO 9773, *Plastics – Determination of burning behaviour of thin flexible vertical specimens in contact with a small-flame ignition source*

ITU-T Recommendation K.44, *Resistibility tests for telecommunication equipment exposed to overvoltages and overcurrents – Basic recommendation*

## **2 Terms and definitions**

### **2.1 Definitions in alphabetical order**

For the purposes of this document, the following terms and definitions apply.

	Subclause
ACCESSIBLE .....	2.8.3
AUDIO AMPLIFIER.....	2.2.1
AVAILABLE POWER.....	2.3.7
BASIC INSULATION.....	2.6.3
BY HAND.....	2.8.4
CLASS I.....	2.6.1
CLASS II.....	2.6.2
CLEARANCE.....	2.6.11
CONDUCTIVELY CONNECTED TO THE MAINS.....	2.4.4
CONDUCTIVE PATTERN.....	2.7.13
CREEPAGE DISTANCE.....	2.6.12
DIRECTLY CONNECTED TO THE MAINS.....	2.4.3
DOUBLE INSULATION.....	2.6.4
ELECTRONIC MUSICAL INSTRUMENT.....	2.2.2
FIRE ENCLOSURE.....	2.8.10
HAZARDOUS LIVE.....	2.6.10
IMAGERY.....	2.2.8
INSTRUCTED PERSON.....	2.8.6
ISOLATING TRANSFORMER.....	2.7.1
LASER.....	2.2.7
LASER SYSTEM.....	2.2.6
LOAD TRANSDUCER.....	2.5.4

MAINS .....	2.4.1
MAINS SWITCH .....	2.7.11
MANUALLY OPERATED MECHANICAL SWITCH .....	2.7.10
MICRO-DISCONNECTION .....	2.7.7
NOISE SIGNAL .....	2.5.2
NON-CLIPPED OUTPUT POWER .....	2.3.4
PERMANENTLY CONNECTED APPARATUS.....	2.4.2
PINK NOISE .....	2.5.1
PORTABLE APPARATUS.....	2.2.10
POTENTIAL IGNITION SOURCE.....	2.8.11
PRINTED BOARD .....	2.7.12
PROFESSIONAL APPARATUS.....	2.2.12
PROTECTIVE EARTHING TERMINAL .....	2.4.6
PROTECTIVE SCREENING .....	2.6.8
PROTECTIVE SEPARATION.....	2.6.7
PTC THERMISTOR .....	2.7.8
RATED CURRENT CONSUMPTION .....	2.3.6
RATED LOAD IMPEDANCE .....	2.3.5
RATED POWER CONSUMPTION.....	2.3.10
RATED SUPPLY VOLTAGE .....	2.3.1
REINFORCED INSULATION .....	2.6.6
REMOTE CONTROL .....	2.2.9
REMOTE POWER FEEDING.....	2.4.8
REQUIRED WITHSTAND VOLTAGE.....	2.3.8
RIPPLE FREE.....	2.3.3
ROUTINE TEST.....	2.8.2
SAFETY INTERLOCK .....	2.7.9
SEPARATING TRANSFORMER .....	2.7.2
SKILLED PERSON .....	2.8.5
SOURCE TRANSDUCER .....	2.5.3
SPECIAL BATTERY.....	2.7.14
SPECIAL SUPPLY APPARATUS.....	2.2.5
STAND-BY.....	2.8.8
SUPPLEMENTARY INSULATION .....	2.6.5
SUPPLY APPARATUS .....	2.2.3
SUPPLY APPARATUS FOR GENERAL USE .....	2.2.4
TELECOMMUNICATION NETWORK .....	2.4.7
TELECOMMUNICATION NETWORK TRANSIENT VOLTAGE.....	2.3.9
TERMINAL .....	2.4.5
THERMAL CUT-OUT .....	2.7.4
THERMAL LINK.....	2.7.5
THERMAL RELEASE .....	2.7.3
TNV CIRCUIT.....	2.4.9

TNV-0 CIRCUIT.....	2.4.10
TNV-1 CIRCUIT.....	2.4.11
TNV-2 CIRCUIT.....	2.4.12
TNV-3 CIRCUIT.....	2.4.13
TOUCH CURRENT .....	2.6.9
TRANSPORTABLE APPARATUS .....	2.2.11
TRIP-FREE .....	2.7.6
TYPE TEST.....	2.8.1
USER .....	2.8.7
WOOD-BASED MATERIAL.....	2.8.9
WORKING VOLTAGE .....	2.3.2

## **2.2 Types of apparatus**

### **2.2.1**

#### **AUDIO AMPLIFIER**

either an independent audio signal amplifying apparatus or the audio signal amplifying part of an apparatus to which this standard applies

### **2.2.2**

#### **ELECTRONIC MUSICAL INSTRUMENT**

electronic apparatus such as an electronic organ, electronic piano or music synthesiser that produces music under the control of the USER

### **2.2.3**

#### **SUPPLY APPARATUS**

apparatus which takes power from the MAINS and from which one or more other apparatus are fed

### **2.2.4**

#### **SUPPLY APPARATUS FOR GENERAL USE**

SUPPLY APPARATUS which can be used without special measures not only for the supply of apparatus within the scope of this standard, but also for the supply of other appliances or devices, for example pocket-calculators

### **2.2.5**

#### **SPECIAL SUPPLY APPARATUS**

SUPPLY APPARATUS which is designed to be used only for the supply of specified apparatus within the scope of this standard

### **2.2.6**

#### **LASER SYSTEM**

LASER in combination with an appropriate laser energy source with or without additional incorporated components

Note 1 to entry: See 3.48 of IEC 60825-1:2007.

### **2.2.7**

#### **LASER**

device which can be made to produce or amplify electromagnetic radiation in the wavelength range from 180 nm to 1 mm primarily by the process of controlled stimulated emission

Note 1 to entry: See 3.41 of IEC 60825-1:2007.

Note 2 to entry: Devices to which this definition does not apply are light emitting diodes (LEDs) used for displays, infrared remote controls, infrared audio/visual signal transmission and optocouplers.

### 2.2.8

#### IMAGERY

processing, editing, manipulation and/or storing of video signals

### 2.2.9

#### REMOTE CONTROL

controlling of an apparatus from a distance, for example mechanically, electrically, acoustically or by means of radiation

### 2.2.10

#### PORTABLE APPARATUS

apparatus specifically designed to be carried easily, the mass of which does not exceed 18 kg

### 2.2.11

#### TRANSPORTABLE APPARATUS

apparatus, the mass of which exceeds 18 kg, specifically designed to be moved frequently from place to place

Note 1 to entry: Examples of TRANSPORTABLE APPARATUS are musical instruments and their associated amplifiers.

### 2.2.12

#### PROFESSIONAL APPARATUS

apparatus for use in trades, professions or industries and which is not intended for sale to the general public

Note 1 to entry: The designation should be specified by the manufacturer.

## 2.3 Ratings and electrical values

### 2.3.1

#### RATED SUPPLY VOLTAGE

supply voltage or voltage range (for three-phase supply, the line-to-line voltage) for which the manufacturer has designed the apparatus

### 2.3.2

#### WORKING VOLTAGE

highest voltage, non-repetitive transients being disregarded, to which the insulation under consideration is or can be subjected when the apparatus is operating at its RATED SUPPLY VOLTAGE under normal operating conditions

### 2.3.3

#### RIPPLE FREE

d.c. voltage with a r.m.s. value of a ripple content of not more than 10 % of the d.c. component; the maximum peak voltage does not exceed 140 V for a nominal 120 V RIPPLE FREE d.c. system, and does not exceed 70 V for a nominal 60 V RIPPLE FREE d.c. system

### 2.3.4

#### NON-CLIPPED OUTPUT POWER

sine-wave power dissipated in the RATED LOAD IMPEDANCE, measured at 1 000 Hz at the onset of clipping on either one, or both peaks

Note 1 to entry: In cases where an amplifier is not intended for operation at 1 000 Hz, a test frequency at the peak response shall be used.

### 2.3.5

#### RATED LOAD IMPEDANCE

resistance, specified by the manufacturer, by which an output circuit should be terminated

### **2.3.6**

#### **RATED CURRENT CONSUMPTION**

current consumption of an apparatus operating at its RATED SUPPLY VOLTAGE under normal operating conditions

### **2.3.7**

#### **AVAILABLE POWER**

maximum power which can be drawn from the supplying circuit through a resistive load whose value is chosen to maximise the power for more than 2 min when the circuit supplied is disconnected

Note 1 to entry: See Figure 1.

### **2.3.8**

#### **REQUIRED WITHSTAND VOLTAGE**

peak voltage that the insulation under consideration is required to withstand

### **2.3.9**

#### **TELECOMMUNICATION NETWORK TRANSIENT VOLTAGE**

highest peak voltage expected at the TELECOMMUNICATION NETWORK connection point of the apparatus, arising from external transients on the network

### **2.3.10**

#### **RATED POWER CONSUMPTION**

power in watts consumed in an apparatus operating at its RATED SUPPLY VOLTAGE under normal operating conditions

## **2.4 Supply and external connections**

### **2.4.1**

#### **MAINS**

power source with a nominal voltage of more than 35 V (peak) a.c. or d.c. which is not used solely to supply apparatus specified in 1.1.1

### **2.4.2**

#### **PERMANENTLY CONNECTED APPARATUS**

apparatus which is intended for connection to the MAINS by a connection which cannot be loosened BY HAND

### **2.4.3**

#### **DIRECTLY CONNECTED TO THE MAINS**

electrical connection with the MAINS in such a way that a connection to either pole of the MAINS causes in that connection a permanent current equal to or greater than 9 A, protective devices in the apparatus being not short-circuited

Note 1 to entry: A current of 9 A is chosen as the minimum breaking current of a 6 A fuse.

### **2.4.4**

#### **CONDUCTIVELY CONNECTED TO THE MAINS**

electrical connection with the MAINS in such a way that a connection through a resistance of 2 000  $\Omega$  to either pole of the MAINS causes in that resistance a permanent current greater than 0,7 mA (peak), the apparatus not being connected to earth

### **2.4.5**

#### **TERMINAL**

part of an apparatus by which connection is made to external conductors or other apparatus

Note 1 to entry: A TERMINAL may contain several contacts.

#### 2.4.6

##### PROTECTIVE EARTHING TERMINAL

TERMINAL to which parts are connected which are required to be connected to earth for safety reasons

#### 2.4.7

##### TELECOMMUNICATION NETWORK

metallically-terminated transmission medium intended for communication between apparatus that may be located in separate buildings, excluding

- the MAINS systems for supply, transmission and distribution of electrical power, if used as a telecommunication transmission medium;
- television distribution systems using cable

Note 1 to entry: The term TELECOMMUNICATION NETWORK is defined in terms of its functionality, not its electrical characteristics. A TELECOMMUNICATION NETWORK is not itself defined as being a TNV CIRCUIT. Only the circuits in apparatus are so classified.

Note 2 to entry: A TELECOMMUNICATION NETWORK may be

- publicly or privately owned;
- subject to transient overvoltages due to atmospheric discharges and faults in power distribution systems;
- subject to permanent longitudinal (common mode) voltages induced from nearby power lines or electric traction lines.

Note 3 to entry: Examples of TELECOMMUNICATION NETWORKS are:

- a public switched telephone network;
- a public data network;
- an ISDN network;
- a private network with electrical interface characteristics similar to the above.

#### 2.4.8

##### REMOTE POWER FEEDING

supply of power to apparatus via a cable network, for example a TELECOMMUNICATION NETWORK or a cable distribution network for antenna signals

#### 2.4.9

##### TNV CIRCUIT

circuit which is in the apparatus and to which the ACCESSIBLE area of contact is limited (except for a TNV-0 CIRCUIT) and that is so designed and protected that, under normal operating and fault conditions, the voltages do not exceed specified limiting values

Note 1 to entry: A TNV CIRCUIT is considered to be a circuit which is not CONDUCTIVELY CONNECTED TO THE MAINS.

Note 2 to entry: The specified limiting values of voltages under normal operating and fault conditions are given in Annex B. For requirements regarding accessibility of TNV CIRCUITS, see 4.2.1 of IEC 62151:2001.

Note 3 to entry: TNV CIRCUITS are classified as TNV-0, TNV-1, TNV-2 and TNV-3 circuits as defined in 2.4.10, 2.4.11, 2.4.12, and 2.4.13 respectively.

Note 4 to entry: The voltage relationships between TNV CIRCUITS are shown in the Table 1.

**Table 1 – Voltage ranges of TNV-CIRCUITS**

Overvoltages from TELECOMMUNICATION NETWORKS possible?	Voltage ranges	
	Within TNV-0 CIRCUIT limits	Exceeding TNV-0 CIRCUIT limits but within TNV CIRCUIT limits
Yes	TNV-1 CIRCUIT	TNV-3 CIRCUIT
No	TNV-0 CIRCUIT	TNV-2 CIRCUIT

#### **2.4.10**

##### **TNV-0 CIRCUIT**

TNV CIRCUIT:

- whose voltages do not exceed a safe value under normal operating conditions and under fault conditions; and
- which is not subject to overvoltages from TELECOMMUNICATION NETWORKS

Note 1 to entry: The limiting values of voltages under normal operating and fault conditions are specified in 9.1.1.2 and 11.1 respectively.

#### **2.4.11**

##### **TNV-1 CIRCUIT**

TNV CIRCUIT:

- whose voltages do not exceed the limits for a TNV-0 CIRCUIT under normal operating conditions; and
- on which overvoltages from TELECOMMUNICATION NETWORKS are possible

#### **2.4.12**

##### **TNV-2 CIRCUIT**

TNV CIRCUIT:

- whose voltages exceed the limits for a TNV-0 CIRCUIT under normal operating conditions; and
- which is not subject to overvoltages from TELECOMMUNICATION NETWORKS

#### **2.4.13**

##### **TNV-3 CIRCUIT**

TNV CIRCUIT:

- whose voltages exceed the limits for a TNV-0 CIRCUIT under normal operating conditions; and
- on which overvoltages from TELECOMMUNICATION NETWORKS are possible

### **2.5 Signals, sources, loads**

#### **2.5.1**

##### **PINK NOISE**

NOISE SIGNAL whose energy per unit bandwidth ( $\frac{\Delta W}{\Delta f}$ ) is inversely proportional to frequency

#### **2.5.2**

##### **NOISE SIGNAL**

stationary random signal having normal probability distribution of instantaneous values

Note 1 to entry: Unless otherwise stated, the mean value is zero.

#### **2.5.3**

##### **SOURCE TRANSDUCER**

apparatus intended to convert the energy of a non-electrical signal to electrical energy

Note 1 to entry: Examples are microphone, image sensor, magnetic reproducing head, LASER pick-up.

#### **2.5.4**

##### **LOAD TRANSDUCER**

apparatus intended to convert the energy of an electrical signal into another form of energy

Note 1 to entry: Examples may include a loudspeaker, picture tube, liquid crystal display, magnetic recording head.

## 2.6 Protection against electric shock, insulations

### 2.6.1

#### CLASS I

design in which protection against electric shock does not rely on BASIC INSULATION only, but which includes an additional safety precaution in such a way that means are provided for the connection of ACCESSIBLE conductive parts to the protective (earthing) conductor in the fixed wiring of the installation, in such a way that ACCESSIBLE conductive parts cannot become HAZARDOUS LIVE in the event of a failure of the BASIC INSULATION

Note 1 to entry: Such a design may have parts of CLASS II.

### 2.6.2

#### CLASS II

design in which protection against electric shock does not rely on BASIC INSULATION only, but in which additional safety precautions, such as DOUBLE INSULATION or REINFORCED INSULATION, are provided, there being no provision for protective earthing or reliance upon installation conditions

### 2.6.3

#### BASIC INSULATION

insulation applied to HAZARDOUS LIVE parts to provide basic protection against electric shock

Note 1 to entry: BASIC INSULATION may also serve as functional insulation.

### 2.6.4

#### DOUBLE INSULATION

insulation comprising both BASIC INSULATION and SUPPLEMENTARY INSULATION

### 2.6.5

#### SUPPLEMENTARY INSULATION

independent insulation applied in addition to BASIC INSULATION in order to reduce the risk of electric shock in the event of a failure of the BASIC INSULATION

### 2.6.6

#### REINFORCED INSULATION

single insulation applied to HAZARDOUS LIVE parts which provides a degree of protection against electric shock equivalent to DOUBLE INSULATION

Note 1 to entry: REINFORCED INSULATION may comprise several layers which cannot be tested singly as BASIC INSULATION or SUPPLEMENTARY INSULATION.

### 2.6.7

#### PROTECTIVE SEPARATION

separation between circuits by means of basic and supplementary protection (BASIC INSULATION plus SUPPLEMENTARY INSULATION or plus PROTECTIVE SCREENING) or by an equivalent protective provision, for example REINFORCED INSULATION

### 2.6.8

#### PROTECTIVE SCREENING

separation from HAZARDOUS LIVE parts by means of an interposed conductive screen, connected to the PROTECTIVE EARTHING TERMINAL

### 2.6.9

#### TOUCH CURRENT

electric current through a human body when it touches one or more ACCESSIBLE parts

**2.6.10**

**HAZARDOUS LIVE**

electrical condition of an object from which a hazardous TOUCH CURRENT (electric shock) could be drawn

Note 1 to entry: See 9.1.1.

**2.6.11**

**CLEARANCE**

shortest distance in air between two conductive parts

**2.6.12**

**CREEPAGE DISTANCE**

shortest distance along the surface of an insulating material between two conductive parts

**2.7 Components**

**2.7.1**

**ISOLATING TRANSFORMER**

transformer with PROTECTIVE SEPARATION between the input and output windings

**2.7.2**

**SEPARATING TRANSFORMER**

transformer, the input windings of which are separated from the output windings by at least BASIC INSULATION

Note 1 to entry: Such transformers may have parts meeting the requirements of ISOLATING TRANSFORMERS.

**2.7.3**

**THERMAL RELEASE**

device which prevents the maintenance of excessively high temperatures in certain parts of the apparatus by disconnecting these parts from their supply

Note 1 to entry: PTC THERMISTORS (see 2.7.8) are not THERMAL RELEASES in the sense of this definition.

**2.7.4**

**THERMAL CUT-OUT**

THERMAL RELEASE with reset which has no provision for temperature setting by the USER

Note 1 to entry: A THERMAL CUT-OUT may be of the automatic or of the manual reset type.

**2.7.5**

**THERMAL LINK**

THERMAL RELEASE without reset, which operates only once and then requires partial or complete replacement

**2.7.6**

**TRIP-FREE**

automatic action, with a reset actuating member, so designed that the automatic action is independent of manipulation or position of the reset mechanism

**2.7.7**

**MICRO-DISCONNECTION**

adequate contact separation so as to ensure functional security

Note 1 to entry: There is a requirement for the dielectric strength of the contact gap but no dimensional requirement.

### 2.7.8

#### PTC THERMISTOR

thermally sensitive semiconductor resistor, which shows a step-like increase in its resistance when the increasing temperature reaches a specific value

Note 1 to entry: The change of temperature is obtained either by the flow of current through the thermosensitive element, or by a change in the ambient temperature, or by a combination of both.

### 2.7.9

#### SAFETY INTERLOCK

means either of preventing access to a hazardous area until the hazard is removed or of automatically removing the hazardous condition when access is gained

### 2.7.10

#### MANUALLY OPERATED MECHANICAL SWITCH

device operated BY HAND, not incorporating semiconductors, and situated anywhere in the circuit of the apparatus, which can interrupt the intended function, such as sound and/or vision, by moving contacts

Note 1 to entry: Examples of MANUALLY OPERATED MECHANICAL SWITCHES are single-pole or all-pole MAINS SWITCHES, functional switches and switching systems which, for example, can be a combination of relays and switches controlling the relays.

### 2.7.11

#### MAINS SWITCH

MANUALLY OPERATED MECHANICAL SWITCH which interrupts either one pole or all poles of the MAINS, except the protective earthing conductor

### 2.7.12

#### PRINTED BOARD

base material cut to size, containing all needed holes and bearing at least one CONDUCTIVE PATTERN

### 2.7.13

#### CONDUCTIVE PATTERN

configuration formed by electrically conductive material of a PRINTED BOARD

### 2.7.14

#### SPECIAL BATTERY

rechargeable battery or group of rechargeable batteries, identified by battery manufacturer's name and catalogue number, provided with the apparatus or recommended by the manufacturer

### 2.7.15

#### COIN CELL BATTERY

#### BUTTON CELL BATTERY

small, single cell battery having a diameter greater than its height

## 2.8 Miscellaneous

### 2.8.1

#### TYPE TEST

test of one or more specimens made on a certain design to show that the design meets all requirements of this standard

### 2.8.2

#### ROUTINE TEST

test to which each specimen is subjected during or after manufacture to ascertain whether it complies with certain criteria

**2.8.3**

**ACCESSIBLE**

possibility of touching by the test finger according to IEC 61032:1997, test probe B

Note 1 to entry: Any ACCESSIBLE area of a non-conductive part is considered as being covered with a conductive layer (see Figure 3 as an example).

**2.8.4**

**BY HAND**

operation that does not require the use of any object such as a tool, coin, etc.

**2.8.5**

**SKILLED PERSON**

person with relevant education and experience to enable him or her to avoid dangers and to prevent risks which electricity may create

**2.8.6**

**INSTRUCTED PERSON**

person adequately advised or supervised by a SKILLED PERSON to enable him or her to avoid dangers and to prevent risks which electricity may create

**2.8.7**

**USER**

any person, other than a SKILLED PERSON or an INSTRUCTED PERSON, who may come into contact with the apparatus

**2.8.8**

**STAND-BY**

operating condition where the main functions, such as sound and/or vision, are switched-off and where the apparatus is only partly in operation

Note 1 to entry: In this condition, permanent functions, such as a clock, are maintained and it allows the apparatus to be brought into full operation, for example by REMOTE CONTROL or automatically.

**2.8.9**

**WOOD-BASED MATERIAL**

material in which the main ingredient is machined natural wood, coupled with a binder

Note 1 to entry: Examples of WOOD-BASED MATERIAL are materials incorporating ground or chipped wood, such as hard fibre board or chip board.

**2.8.10**

**FIRE ENCLOSURE**

part of the apparatus intended to minimize the spread of fire or flames from within

**2.8.11**

**POTENTIAL IGNITION SOURCE**

possible fault which can start a fire if the open-circuit voltage measured across an interruption or faulty contact exceeds a value of 50 V (peak) a.c. or d.c. and the product of the peak value of this voltage and the measured r.m.s. current under normal operating conditions exceeds 15 VA

Note 1 to entry: Such a faulty contact or interruption in an electrical connection includes those which may occur in CONDUCTIVE PATTERNS ON PRINTED BOARDS.

Note 2 to entry: An electronic protection circuit may be used to prevent such a fault from becoming a POTENTIAL IGNITION SOURCE.

### 2.8.12

#### PASSIVE FLAMMABILITY

flammability caused by external heating of the component

Note 1 to entry: It can be caused for example, by flames.

## 3 General requirements

### 3.1 General

The apparatus shall be so designed and constructed as to present no danger when used for its intended purpose, either in normal operating conditions or under fault conditions, particularly providing protection against

- hazardous currents passing through the human body (electric shock);
- excessive temperatures;
- hazardous radiations;
- effects of implosion and explosion;
- mechanical instability;
- injury by mechanical parts; and
- start and spread of fire.

In general, compliance is checked under normal operating conditions and under fault conditions, as specified in 4.2 and 4.3, by carrying out all the relevant tests specified.

### 3.2 Designation of classes

Apparatus designed to be fed from the MAINS shall be constructed according to the requirements of CLASS I, or CLASS II apparatus.

### 3.3 Constructions and components not specifically covered

Where the equipment involves technologies, components and materials or methods of construction not specifically covered in this standard, the equipment shall provide safety measures not less than that generally afforded by this standard and the principles of safety contained herein.

### 3.4 Components and subassemblies that comply with IEC 62368-1

Components and subassemblies that comply with IEC 62368-1 are acceptable as part of an apparatus covered by this standard without further evaluation other than to give consideration to the appropriate use of the component or subassembly in the end-product.

## 4 General test conditions

### 4.1 Conduct of tests

#### 4.1.1 Tests according to this standard are TYPE TESTS.

NOTE For ROUTINE TEST, recommendations are given in Annex N.

#### 4.1.2 The sample or samples under test shall be representative of the apparatus the USER would receive, or shall be the actual apparatus ready for shipment to the USER.

As an alternative to carrying out tests on the complete apparatus, tests may be carried out separately on circuits, components or subassemblies outside the apparatus, provided that

*inspection of the apparatus and circuit arrangements ensures that such testing will indicate that the assembled apparatus would conform to the requirements of this standard.*

*If any such test indicates a likelihood of non-compliance in the complete apparatus, the test shall be repeated in the apparatus.*

*If a test specified in this standard could be destructive, it is permitted to use a physical model to represent the condition to be evaluated.*

*The tests should be carried out in the following order:*

- *component or material pre-selection;*
- *component or subassembly bench tests;*
- *tests where the apparatus is not energized;*
- *live tests*
  - *under normal operating conditions,*
  - *under abnormal operating conditions,*
  - *involving likely destruction.*

NOTE In view of the amount of resources involved in testing and in order to minimize waste, all parties concerned can jointly consider the test programme, the test samples and the test sequence.

**4.1.3** *Unless otherwise specified, the tests are carried out under normal operating conditions at:*

- *an ambient temperature between 15 °C and 35 °C, and*
- *a relative humidity of 75 % maximum.*

**4.1.4** *Any position of intended use of the apparatus, normal ventilation not being impeded.*

*The temperature measurements shall be carried out with the apparatus positioned in accordance with the instructions for use provided by the manufacturer, or, in the absence of instructions, the apparatus shall be positioned 5 cm behind the front edge of an open-fronted wooden test box with 1 cm free space along the sides and top and 5 cm depth behind the apparatus.*

*Tests on apparatus, intended to be part of an assembly not provided by the apparatus manufacturer, shall be carried out according to the instructions for use provided by the apparatus manufacturer, specifically those dealing with proper ventilation.*

*The apparatus shall also comply with Table 3 when tested on an open bench.*

**4.1.5** *The characteristics of the supply source, except those specified in 4.2.2, used during the tests shall not appreciably influence the test results.*

*Examples of such characteristics are source impedance and waveform.*

**4.1.6** *Where relevant, a standard signal consisting of PINK NOISE, band-limited by a filter whose response conforms to that given in Figure C.1 in Annex C.*

NOTE If appropriate, the standard signal can be used to modulate a carrier wave.

*The output measuring equipment shall indicate true r.m.s. values for crest factors up to at least 3, and the frequency response shall conform to that shown in Annex C.*

**4.1.7** *The a.c. values given in this standard are r.m.s. values, unless specified otherwise.*

The d.c. values given in this standard are RIPPLE FREE values.

## 4.2 Normal operating conditions

**4.2.1** Normal operating conditions are the most unfavourable combination of the following conditions.

**4.2.2** The apparatus, except battery-operated apparatus, is connected to a supply voltage of 0,9 times or 1,1 times of any RATED SUPPLY VOLTAGE for which the apparatus is designed.

For battery-operated apparatus a fully charged rechargeable battery or dry batteries in a fresh condition are used.

RATED CURRENT CONSUMPTION and RATED POWER CONSUMPTION are measured at the RATED SUPPLY VOLTAGE. For RATED CURRENT CONSUMPTION or RATED POWER CONSUMPTION measurements of television sets, the following settings shall apply:

- the 'three vertical bar signal' shall be used as defined in 3.2.1.3 of IEC 60107-1:1997; and
- USER ACCESSIBLE picture controls shall be adjusted so as to obtain the maximum power consumption; and
- sound settings shall be as defined in 4.2.5 a) of this standard.

In case of doubt, tests may also be performed at the value of any RATED SUPPLY VOLTAGE.

For apparatus having a RATED SUPPLY VOLTAGE range not requiring the adjustment of a voltage setting device, the apparatus is connected to a supply voltage of 0,9 times the lower limit or 1,1 times the upper limit of any RATED SUPPLY VOLTAGE range; moreover, the apparatus is connected to any nominal supply voltage within the RATED SUPPLY VOLTAGE range marked on the apparatus.

Any rated supply frequency marked on the apparatus is used.

Any type of supply for which the apparatus is designed to be used.

For d.c. supply any polarity is used, unless this is prevented by the construction of the apparatus.

**4.2.3** Any position of controls which are ACCESSIBLE to the USER for adjustment BY HAND, including REMOTE CONTROLS, excluding voltage setting devices complying with 14.9 and volume controls and tone controls.

Any cable connected REMOTE CONTROL device, detachable by a connector or a similar device, is connected or not.

A cover, enclosing a LASER SYSTEM, which can be opened BY HAND, is opened fully, opened partly or closed.

**4.2.4** In the case of single-phase supply, any earth TERMINAL and any PROTECTIVE EARTHING TERMINAL may be connected to either pole of the isolated supply source used during the test.

In the case of a supply other than single phase, any earth TERMINAL and any PROTECTIVE EARTHING TERMINAL may be connected to the neutral or to any phase of the isolated supply source used during the test.

**4.2.5** In addition, for an AUDIO AMPLIFIER:

- a) *The apparatus is operated in such a way as to deliver one-eighth of the NON-CLIPPED OUTPUT POWER to the RATED LOAD IMPEDANCE using the standard signal described in 4.1.6 with the tone controls set to their mid position.*

*Where the NON-CLIPPED OUTPUT POWER cannot be obtained using the standard signal, one-eighth of the maximum attainable output power is taken.*

*As an alternative, where the amplifier function is not adversely affected, a sine wave of 1 kHz or where applicable, another frequency corresponding to the geometric mean of the upper and lower –3 dB response points of the relevant part of the apparatus may be used to supply each channel.*

*If the result of a measurement performed with a sine wave does not comply with this standard, the measurement with PINK NOISE is decisive.*

*When determining whether a part or output TERMINAL contact is HAZARDOUS LIVE according to 9.1.1.2 and 11.1, the apparatus shall be operated with a sinusoidal input test signal of 1 kHz or where applicable, another frequency corresponding to the geometric mean of the upper and lower –3 dB response points of the relevant amplifier part of the apparatus, sufficient in amplitude for the apparatus to deliver the NON-CLIPPED OUTPUT POWER into its RATED LOAD IMPEDANCE. Open-circuit output voltage is determined after the load is removed.*

- b) *The most unfavourable RATED LOAD IMPEDANCE of any output circuit is connected.*
- c) *Organs or similar instruments which have a tone-generator unit are operated with any combination of two bass pedal keys, if any, and ten manual keys depressed, and all stops and tabs which can increase the output power are activated.*

*For AUDIO AMPLIFIERS used in an ELECTRONIC MUSICAL INSTRUMENT which does not generate a continuous tone, the standard signal described in 4.1.6 is applied to the signal input TERMINAL or to the appropriate input stage of the AUDIO AMPLIFIER.*

- d) *Where the intended amplifier function depends on phase difference between two channels, there shall be a phase difference of 90° between the signals applied to the two channels.*
- e) *For equipment containing multi-channel amplifiers, where each channel can be operated independently, each channel shall be operated using the RATED LOAD IMPEDANCE at the output power level that corresponds to 1/8 of the NON-CLIPPED OUTPUT POWER. Where some channels cannot be operated independently, those channels shall be operated using the RATED LOAD IMPEDANCE at the output power level that corresponds, by design, to 1/8 of the NON-CLIPPED OUTPUT POWER of the adjustable amplifier channel(s).*

**4.2.6** *For apparatus incorporating motors, load conditions for the motor are chosen which may occur during intended use, including stalling BY HAND if this is possible.*

**4.2.7** *An apparatus supplying power to other apparatus is loaded to give its rated power or is not loaded.*

**4.2.8** *A SUPPLY APPARATUS to be used inside apparatus for which it is intended exclusively, is tested within such apparatus after installation according to the manufacturer's instruction for use.*

**4.2.9** *In addition, for Citizen's Band apparatus, the RATED LOAD IMPEDANCE is connected or not to the antenna TERMINAL or, if applicable, to a telescopic antenna extended to any length. The transmitting test conditions are specified in IEC/TS 61149.*

**4.2.10** *Antenna positioners shall comply with all of the following requirements:*

**4.2.10.1** *For antenna positioners in combination with their control and SUPPLY APPARATUS:*

- four consecutive movements from one endstop to the opposite endstop;*
- followed by a 15 min resting period.*

The movements and the resting periods are repeated as many times as necessary for the relevant tests. For temperature measurements the movements and the resting periods are repeated until a steady state of temperature has been reached but not longer than 4 h.

After the last movement period, the 15 min resting period does not apply to the temperature measurements.

**4.2.10.2** In addition, for satellite antenna positioners consisting of a power supply and control unit without a motor drive system, the power supply unit shall be loaded in accordance with the marked output rating and operated with a duty cycle of 5 min on, and 15 min off.

**4.2.11** Apparatus designed to be supplied exclusively by a SPECIAL SUPPLY APPARATUS specified by the manufacturer of the apparatus, shall be tested together with this SPECIAL SUPPLY APPARATUS.

The supply voltage for the SPECIAL SUPPLY APPARATUS is determined in accordance with 4.2.2.

Where a voltage setting device for the output voltage of the SPECIAL SUPPLY APPARATUS is provided, it shall be adjusted to the RATED SUPPLY VOLTAGE of the apparatus under test.

**4.2.12** Apparatus which can be supplied by SUPPLY APPARATUS FOR GENERAL USE shall be supplied by a test power supply with a sufficient current capacity according to Table 2 corresponding to the RATED SUPPLY VOLTAGE of the apparatus under test. The values of no-load voltage given in Table 2 are subject to the under- and over-voltage provisions specified in 4.2.2.

**Table 2 – Test power supply**

RATED SUPPLY VOLTAGE V d.c.	Nominal no-load voltage V d.c.	Internal resistance $\Omega$
1,5	2,25	0,75
3,0	4,50	1,50
4,5	6,75	2,25
6,0	9,00	3,00
7,5	11,25	3,75
9,0	13,50	4,50
12,0	18,00	6,00

The test power supply voltage and current parameters are not limited to those provided in this table. The parameters in the table are representative for supply apparatus having output voltage(s) < 12 V d.c. and rated output current < 1 A.

**4.2.13** Apparatus intended to be used with optional detachable legs or stands supplied by the manufacturer of the apparatus are tested with or without legs or stands fitted.

### 4.3 Fault conditions

**4.3.1** For operation under fault conditions, in addition to the normal operating conditions mentioned in 4.2, each of the following conditions is applied one at a time and, associated with it, those other fault conditions which are a logical consequence.

NOTE 1 The logical consequences of a fault condition are those which occur when a fault is applied.

Circuits, or parts of a circuit supplied with an open circuit voltage not exceeding 35 V (peak) a.c. or d.c. and not generating voltages above that value, are not considered to present a fire hazard if the current which may be drawn from the supplying circuit for more than 2 min at any

*load, including short-circuit, is limited to not more than 0,2 A. Such supplied circuits are not subject to fault conditions testing.*

*An example of a test circuit to measure the voltage and the current is given in Figure 1.*

NOTE 2 Examination of the apparatus and all its circuit diagrams, excluding the internal circuit diagrams of integrated circuits, generally shows the fault conditions that are likely to create a hazard and that are to be applied. These are applied in sequence, in the order that is most convenient.

The examination of the apparatus and circuit diagrams indicate the operating conditions under which simulated faults are applied in order to produce the most unfavourable effects. In most cases, the effects of a simulated fault are most unfavourable if the simulated fault is applied while the apparatus is in full operation.

However, for some parts, the most unfavourable effects can occur if the simulated fault is applied before switching on the apparatus. It is also possible that the most unfavourable effects could occur when a simulated fault is applied when the apparatus is in a STAND-BY condition.

NOTE 3 When carrying out the examination in NOTE 2, the operating characteristics of integrated circuits are taken into consideration.

NOTE 4 The fault tests are only to be made in the wooden test box mentioned in 4.1.4, if no installation instructions are provided and there is a possibility that the test box will influence the results.

*When a specified fault condition test is carried out, it can cause consequential faults which either interrupt or short-circuit a component. In case of doubt, the fault condition test shall be repeated up to two more times with replacement components in order to check that the same result is always obtained. Should this not be the case, the most unfavourable consequential fault, whether interruption or short circuit, shall be applied together with the specified fault condition.*

**4.3.2** *Short-circuit across CLEARANCES and CREEPAGE DISTANCES, if they are less than the values specified in Clause 13 for BASIC and SUPPLEMENTARY INSULATION, with the exception of insulation between parts of different polarity DIRECTLY CONNECTED TO THE MAINS.*

NOTE For CLEARANCES between parts of different polarity DIRECTLY CONNECTED TO THE MAINS, reference is made to 13.1.

**4.3.3** *Short-circuit across parts of insulating material, the short-circuiting of which might cause an infringement of the requirements regarding protection against electric shock hazard or overheating, with the exception of insulating parts which comply with the requirements of 10.4.*

NOTE This does not imply a need to short-circuit the insulation between turns of coils.

**4.3.4** *Short-circuit, or if applicable, interruption of:*

- *heaters of electronic tubes;*
- *insulation between heaters and cathodes of electronic tubes;*
- *spacings in electronic tubes, excluding picture tubes; and*
- *semiconductor devices, one lead at a time interrupted or any two leads connected together one pair at a time (but see 4.3.5 d)).*

NOTE If electronic tubes are so constructed that a short circuit between certain electrodes is highly improbable or even impossible, the electrodes concerned need not be short-circuited.

**4.3.5** *Short-circuit or disconnection, whichever is more unfavourable, of resistors, capacitors, windings (for example transformers, degaussing coils), loudspeakers, optocouplers, varistors or non-linear passive components, the short-circuiting or disconnection of which might cause an infringement of the requirements regarding protection against electric shock or overheating.*

*These fault conditions do not apply to*

- a) resistors complying with the requirements of 14.2 and, as far as applicable, of 11.2;
- b) PTC THERMISTORS complying with Clauses 15, 17, J.15 and J.17 of IEC 60730-1:2010;
- c) capacitors and RC-units complying with the requirements of 14.3, provided that the voltage at their terminations does not exceed their rated voltage and that their application is in accordance with 8.5 or 8.6;
- d) the insulation between the input and output terminations of optocouplers complying with the requirements of 14.12;
- e) windings and the insulation of transformers and other windings mentioned in 14.4 complying with the requirements of that subclause; and
- f) surge suppression varistors complying with the requirements of 14.13.

**4.3.6** For apparatus containing an AUDIO AMPLIFIER, using the standard signal described in 4.1.6 so as to deliver the most unfavourable output power from zero up to the maximum attainable output power to the RATED LOAD IMPEDANCE or, if applicable, to the most unfavourable load impedance connected to the output TERMINALS including short-circuit and open circuit.

**4.3.7** Motors are stalled.

**4.3.8** Motors, relay coils or the like, intended for short-time or intermittent operation, are operated continuously if this can occur during operation of the apparatus.

**4.3.9** The apparatus is connected simultaneously to alternative types of supply unless this is prevented by the construction.

**4.3.10** Output TERMINALS of apparatus supplying power to other apparatus, except MAINS socket-outlets DIRECTLY CONNECTED TO THE MAINS, are connected to the most unfavourable load impedance, including short circuit. MAINS socket outlets shall be loaded with 1,1 times the highest load possible based on over-current protection and the outlet configuration except where the wiring to the socket outlet has the same cross-sectional area as the MAINS cord.

**4.3.11** The top, sides and the back of an apparatus, if such surfaces have ventilation openings, shall be covered one at a time with a piece of card of 200 g/m<sup>2</sup> density with dimensions not less than each tested surface, covering all openings.

Openings on different surfaces on top of the apparatus (if any) are covered simultaneously by separate pieces of card.

Openings on top of the apparatus, on a surface inclined at an angle greater than 30° and smaller than 60° to the horizontal, from which an obstruction is free to slide, are excluded.

On the back and the sides of the apparatus, the card is attached to the upper edge and allowed to hang freely.

NOTE There is no test for the bottom surface.

**4.3.12** If it is possible to insert USER replaceable batteries with reversed polarity, the apparatus is tested with one or more batteries with both intended and reversed polarity.

NOTE CAUTION, there is a danger of explosion when this test is applied.

**4.3.13** For Citizen's Band apparatus, the most unfavourable load impedance, including short circuit, is connected to the antenna TERMINAL or to the antenna itself, for example a telescopic antenna, when no antenna TERMINAL is provided. The transmitting test conditions are specified in IEC/TS 61149.

**4.3.14** For apparatus to be supplied from an a.c. MAINS and provided with a voltage setting device to be set by the USER, connection to a supply voltage of 250 V a.c., with the MAINS voltage setting device at the most unfavourable position.

**4.3.15** Apparatus designed to be supplied by a SPECIAL SUPPLY APPARATUS with a voltage setting device for the output voltage, specified by the manufacturer of the apparatus, shall be tested by adjusting this voltage setting device to any output voltage.

During this test, 4.2.2 is applied, except that the SPECIAL SUPPLY APPARATUS is fed by its RATED SUPPLY VOLTAGE.

The test need not be made if the current consumption of the apparatus under test cannot exceed 0,2 A for more than 2 min, for example by the operation of a fuse.

**4.3.16** Apparatus which can be supplied by SUPPLY APPARATUS FOR GENERAL USE shall be tested by using a test power supply as specified in Table 2 step by step upwards, starting with the value one step above the value specified for the RATED SUPPLY VOLTAGE of the apparatus under test.

This test is not applied to apparatus having a RATED SUPPLY VOLTAGE equal to or higher than the maximum RATED SUPPLY VOLTAGE in Table 2.

During this test, 4.2.2 is applied, except that the no-load voltages have their nominal values.

The test need not be made if the current consumption of the apparatus under test cannot exceed 0,2 A for more than 2 min, for example by the operation of a fuse.

**4.3.17** For apparatus with a charging circuit, recharge a fully discharged SPECIAL BATTERY with one cell short-circuited.

NOTE See also 11.2 and 14.11.3.

## **5 Marking and instructions**

### **5.1 General requirements**

NOTE Additional requirements for marking and instructions are contained in 4.1.4, 4.2.8, 8.18, 9.1.5, 14.4.2, 14.6.2.4, 14.6.3.2, 14.6.5, Cause 19 and Annex B.

Markings shall be permanent, comprehensible and easily discernible on the apparatus when ready for use.

The information should preferably be on the exterior of the apparatus, excluding the bottom. It is, however, permissible to have it in an area that is easily ACCESSIBLE BY HAND, for example under a lid, or on the exterior of the bottom of a PORTABLE APPARATUS or an apparatus with a mass not exceeding 7 kg, provided that the location of the marking is given in the instructions for use.

Compliance is checked by inspection and by rubbing the marking BY HAND for 15 s with a piece of cloth soaked with water and, at a different place or on a second sample, for 15 s with a piece of cloth soaked with petroleum spirit. After this the marking shall be legible; it shall not be easily possible to remove marking plates and they shall show no curling.

Petroleum spirit, to be used for reference purposes is defined as follows:

The petroleum spirit is an aliphatic solvent hexane having a maximum aromatics content of 0,1 % by volume, a kauri-butanol value of 29, an initial boiling point of approximately 65 °C, a

*dry-point of approximately 69 °C and a specific mass of approximately 0,7 kg/l. As an alternative, it is permitted to use a reagent grade hexane with a minimum of 85 % as n-hexane.*

NOTE The designation "n-hexane" is chemical nomenclature for a "normal" or straight chain hydrocarbon. This petroleum spirit is further identified as a certified ACS (American Chemical Society) reagent grade hexane (CAS# 110-54-3).





Letter symbols for quantities and units shall be in accordance with IEC 60027.

Graphical symbols shall be in accordance with IEC 60417 and ISO 7000, as appropriate.

*Compliance is checked by inspection.*

## 5.2 Identification and supply ratings

The apparatus shall be marked with the following:

- a) maker's or responsible vendor's name, trade mark or identification mark;
- b) model number or type reference;
- c) the symbol for CLASS II for apparatus without functional earth: , IEC 60417-5172 (2003-02)  
for CLASS II apparatus with functional earth: , IEC 60417-6092 (2011-10)
- d) nature of supply:
  - a.c. only with the symbol: , IEC 60417-5032 (2002-10)
  - d.c. only with the symbol: , IEC 60417-5031 (2002-10)
  - a.c. or d.c. with the symbol: , IEC 60417-5033 (2002-10)
  - for three-phase systems, reference is made to IEC 61293;
- e) RATED SUPPLY VOLTAGE or range of the RATED SUPPLY VOLTAGES which can be applied without operating a voltage setting device.  
Apparatus which can be set to different RATED SUPPLY VOLTAGES or ranges of RATED SUPPLY VOLTAGES shall be so constructed that the indication of the voltage or range of voltages to which the apparatus is set, is discernible on the apparatus when ready for use.  
A solidus shall be used for USER selectable ratings, for example "110/230 V" and a hyphen shall be used for a rating range, for example "110-230 V";
- f) rated MAINS frequency (or range of frequencies) in hertz, if safety is dependent on the use of the correct MAINS frequency;
- g) RATED CURRENT CONSUMPTION or RATED POWER CONSUMPTION of apparatus which can be supplied by SUPPLY APPARATUS FOR GENERAL USE. As an alternative the information may be given in the instruction manual.  
The measured consumption at RATED SUPPLY VOLTAGE shall not exceed the marked value by more than 10 %;
- h) RATED CURRENT CONSUMPTION or RATED POWER CONSUMPTION for apparatus intended for connection to an a.c. MAINS supply.  
The measured consumption at RATED SUPPLY VOLTAGE shall not exceed the marked value by more than 10 %.

If an appliance coupler for Class I is used for Class II equipment with functional earth connection, the requirements of Clause 15 and Clause 16 related to Class I construction shall be applied up to the connecting point of the protective (earthing) conductor to the functional earth.

Graphical symbols placed on the apparatus, whether required by this standard or not, shall be in accordance with IEC 60417 or ISO 3864-2 or ISO 7000, if available. In the absence of suitable symbols, the manufacturer may design specific graphical symbols.

Care shall be taken so that additional markings and instructions not required by this standard do not contradict the markings and instructions required by this standard.

Symbols placed on the equipment shall be explained in the user manual.

*Compliance is checked by inspection.*

### **5.3 TERMINALS**

TERMINALS shall be marked as follows:

- a) The wiring TERMINAL intended for connection of the protective earthing conductor associated with the supply wiring:



, IEC 60417-5019 (2006-08)

This symbol shall not be used for other earthing TERMINALS.

- b) TERMINALS which are HAZARDOUS LIVE under normal operating conditions, except TERMINALS for MAINS supply:



, IEC 60417-5036 (2002-10)

- c) Unless the TERMINALS are marked with the type references of the apparatus that are permitted to be connected, output TERMINALS provided for supply of other apparatus except MAINS supply shall be marked with

- the nominal output voltage; and
- the maximum output current or power, if with the most unfavourable load, temperature rises higher than those allowed in Table 3 for normal operating conditions can occur.

Socket-outlets providing MAINS power to other apparatus shall be marked with the power and current which may be drawn.

If there is only one TERMINAL provided for supply of other apparatus, the marking may be put on the apparatus at any place, taking into account 5.1.

*Compliance is checked by inspection.*

### **5.4 Caution marking**

The following markings shall be included as applicable:

- a) Where in a manufacturer's service documentation, for example in circuit diagrams or lists of components, a symbol is used to indicate that a specific component shall be replaced only by the component specified in that documentation for safety reasons, the following symbol shall be used:



, ISO 7000-0434 (2004-01)

This symbol may also be put adjacent to the relevant component.

This symbol shall not be placed on components.

- b) Where a loudspeaker grille, removable from the outside by the use of a tool, coin or other object, is relied on as protective cover (see 9.2), the following marking, or equivalent, shall be visible on the enclosure after removal of the grille:

**CAUTION**

To prevent electric shock hazard, do not connect to mains power supply while grille is removed.

Alternatively, the symbol , IEC 60417-5036 (2002-10) shall be visible after removal of the grille and the caution wording above shall appear in the user instructions, accompanied by the symbol.

- c) If an apparatus contains a USER-replaceable COIN / BUTTON CELL BATTERY, the following:

, ISO 7000-0434 (2004-01), or

 combination of ISO 7000-0434 (2004-01) and ISO 7000-1641 (2004-01).

This marking is not required where these batteries are not intended to be replaced or are only ACCESSIBLE after damaging the apparatus.

*Compliance is checked by inspection.*

NOTE In Finland, Norway and Sweden, CLASS I apparatus which is intended for connection to the building installation wiring via a plug or an appliance coupler, or both, and in addition is intended for connection to other apparatus or a network shall, if safety relies on connection to protective earth or if surge suppressors are connected between the network TERMINALS and ACCESSIBLE parts, have a marking stating that the apparatus must be connected to an earthed MAINS socket-outlet.

## 5.5 Instructions

**5.5.1** When information with regard to safety is required according to this standard, this information shall be given in an instruction for installation or use and supplied with the apparatus. This information shall be given in a language acceptable to the country where the apparatus is intended to be used.

NOTE Reference is made to ISO/IEC Guide 37.

If safety relevant, the following information should be included as far as applicable:

- minimum distances around the apparatus for sufficient ventilation;
- the ventilation should not be impeded by covering the ventilation openings with items, such as newspapers, table-cloths, curtains, etc.;
- no naked flame sources, such as lighted candles, should be placed on the apparatus;
- attention should be drawn to the environmental aspects of battery disposal;
- the use of apparatus in tropical and/or moderate climates.

**5.5.2** In addition, the instructions shall include the following as far as applicable.

- a) For MAINS powered apparatus and for apparatus producing internal voltages greater than 35 V (peak) a.c. or d.c., having no protection against splashing water according to Annex A, the instructions for use shall state that the apparatus shall not be exposed to dripping or splashing and that no objects filled with liquids, such as vases, shall be placed on the apparatus.
- b) A warning that TERMINALS marked with the symbol according to 5.3 b) are HAZARDOUS LIVE and that the external wiring connected to these TERMINALS requires installation by an INSTRUCTED PERSON or the use of ready-made leads or cords.
- c) If an apparatus is provided with a replaceable lithium battery, the following applies:
  - if the battery is intended to be replaced by the USER, there shall be a warning close to the battery or in both the instructions for use and the service instructions;
  - if the battery is not intended to be replaced by the USER, there shall be a warning close to the battery or in the service instructions.

This warning shall include the following or similar text:

**CAUTION**

Danger of explosion if battery is incorrectly replaced.  
Replace only with the same or equivalent type.

- d) A warning that an apparatus with CLASS I construction shall be connected to a MAINS socket outlet with a protective earthing connection.
- e) Instructions to ensure correct and safe installation and interconnection of the apparatus in multimedia systems.
- f) If the apparatus is not tested to the stability requirements of 19.2, 19.3 or 19.4 due to fastening in place, the following or similar text shall be marked on or provided with the apparatus:

**WARNING**

To prevent injury, this apparatus must be securely attached to the floor/wall in accordance with the installation instructions.

- g) A warning that batteries (battery pack or batteries installed) shall not be exposed to excessive heat such as sunshine, fire or the like.
- h) If the apparatus is provided with a CRT with protective film attached to the faceplate as part of the safety implosion protection system in accordance to IEC 61965, the following warning, or wording with a similar meaning, shall be given in the instructions:

**WARNING**

The CRT in this apparatus employs a protective film on the face.  
This film must not be removed as it serves a safety function and removal will increase the risk of serious injury.

- i) The instructions for installation or use provided with non-floor standing televisions likely to be used in the home and weighing over 7 kg shall contain the following information or equivalent:

**WARNING**

Never place a television set in an unstable location. A television set may fall, causing serious personal injury or death. Many injuries, particularly to children, can be avoided by taking simple precautions such as:

- Using cabinets or stands recommended by the manufacturer of the television set.
- Only using furniture that can safely support the television set.
- Ensuring the television set is not overhanging the edge of the supporting furniture.
- Not placing the television set on tall furniture (for example, cupboards or bookcases) without anchoring both the furniture and the television set to a suitable support.
- Not placing the television set on cloth or other materials that may be located between the television set and supporting furniture.
- Educating children about the dangers of climbing on furniture to reach the television set or its controls.

If your existing television set is being retained and relocated, the same considerations as above should be applied.

*Compliance is checked by inspection.*

NOTE 1 In China, the protective earthing of the building installation needs to be isolated from the screen of a cable distribution system. An isolator providing electrical insulation shall comply with insulation resistance of Clause 10.4 for BASIC INSULATION, and the antenna coaxial socket incorporating this isolator should comply with mechanical stress tests in 12.5. It is, however, accepted to provide the insulation external to the equipment, the user manual shall then have the following or similar information in Chinese:

Equipment connected to the protective earthing of the building installation through the MAINS connection or through other equipment with a connection to protective earthing – and to a cable distribution system using coaxial cable, may in some circumstances create a fire hazard. Connection to a cable distribution system has therefore to be provided through a device providing electrical isolation which can withstand insulation resistance for BASIC INSULATION.

NOTE 2 In Norway and Sweden, the screen of the coaxial cable of the television distribution system is normally not earthed at the entrance of the building and there is normally no equipotential bonding system within the building. Therefore the protective earthing of the building installation needs to be isolated from the screen of a coaxial cable based television distribution system.

It is, however, acceptable to provide the insulation external to the apparatus by an adapter or an interconnection cable with galvanic isolator, which may be provided by a retailer, for example.

The user manual shall then have the following or similar information in Norwegian and Swedish language respectively, depending on in what country the apparatus is intended to be used:

“Apparatus connected to the protective earthing of the building installation through the MAINS connection or through other apparatus with a connection to protective earthing – and to a television distribution system using coaxial cable, may in some circumstances create a fire hazard. Connection to a television distribution system therefore has to be provided through a device providing electrical isolation below a certain frequency range (galvanic isolator, see IEC 60728-11)”.

In Norway, due to regulation for CATV-installations, and in Sweden, a galvanic isolator shall provide electrical insulation below 5 MHz. The insulation shall withstand a dielectric strength of 1,5 kV r.m.s., 50 Hz or 60 Hz, for 1 min.

Translation to Norwegian (the Swedish text will also be accepted in Norway): “Apparater som er koplet til beskyttelsesjord via nettplugg og/eller via annet jordtilkøpelt utstyr – og er tilkøpelt et koaksialbasert kabel-TV nett, kan forårsake brannfare. For å unngå dette skal det ved tilkøpling av apparater til kabel-TV nett installeres en galvanisk isolator mellom apparatet og kabel-TV nettet.”

Translation to Swedish: “Apparater som är kopplade till skyddsjord via jordat vägguttag och/eller via annan utrustning och samtidigt är kopplad till kabel-TV nät kan i vissa fall medföra risk för brand. För att undvika detta skall vid anslutning av apparaten till kabel-TV nät galvanisk isolator finnas mellan apparaten och kabel-TV nätet.”

j) For apparatus containing a USER-replaceable COIN / BUTTON CELL BATTERY, the following text or equivalent:

<p><b>WARNING</b></p> <p>Do not ingest the battery, Chemical Burn Hazard</p> <p>(The remote control supplied with) This product contains a coin/button cell battery. If the coin/button cell battery is swallowed, it can cause severe internal burns in just 2 hours and can lead to death.</p> <p>Keep new and used batteries away from children.</p> <p>If the battery compartment does not close securely, stop using the product and keep it away from children.</p> <p>If you think batteries might have been swallowed or placed inside any part of the body, seek immediate medical attention.</p>
--

NOTE The part between the brackets can be deleted if the battery is located in the apparatus instead of the remote control.

This warning is not required where these batteries are not intended to be replaced or are only ACCESSIBLE after damaging the apparatus.

**5.5.3** With regard to devices for disconnection from the MAINS, instructions shall state that:

- a) where the MAINS plug or an appliance coupler is used as the disconnect device, the disconnect device shall remain readily operable;
- b) where an all-pole MAINS SWITCH is used as the disconnect device, the location on the apparatus and the function of the switch shall be described, and the switch shall remain readily operable; and
- c) for PERMANENTLY CONNECTED APPARATUS provided neither with an all-pole MAINS SWITCH nor an all-pole circuit breaker, the installation shall be carried out in accordance with all applicable installation rules.

Marking of the off-position by the relevant symbol according to IEC 60417-5008 (2002-10) or according to IEC 60417-5010 (2002-10) is permitted only for an all-pole MAINS SWITCH which interrupts all poles of the MAINS supply except the protective earthing conductor.

Where marking, signal lamps or similar means might give the impression that the apparatus is completely disconnected from the MAINS, information that states clearly the correct situation shall be included in the instructions. If symbols are used, their meaning shall also be explained in the instructions.

*Compliance is checked by inspection.*

## **6 Hazardous radiations**

### **6.1 Ionizing radiation**

Apparatus including a potential source of ionizing radiation shall be so constructed that personal protection against ionizing radiation is provided under normal operating conditions and under fault conditions.

*Compliance is checked by measurement under the following conditions.*

*In addition to the normal operating conditions, all controls adjustable from the outside BY HAND, by any object such as a tool or a coin, and those internal adjustments or pre-sets which are not locked in a reliable manner, are adjusted so as to give maximum radiation whilst maintaining an intelligible picture for 1 h, at the end of which the measurement is made.*

NOTE 1 Soldered joints and paint lockings are examples of adequate locking.

*The exposure rate at any point outside the apparatus is determined by means of a radiation monitor with an effective area of 10 cm<sup>2</sup>, at a distance of 5 cm from the outer surface of the apparatus.*

*Moreover, the measurement shall be made under fault conditions causing an increase of the high-voltage, provided an intelligible picture is maintained for 1 h, at the end of which the measurement is made.*

*The exposure rate shall not exceed 36 pA/kg (0,5 mR/h or 5 μSv/h).*

NOTE 2 The value is according to ICRP 15, Clause 289.

NOTE 3 In the member countries of CENELEC, the amount of ionizing radiation is regulated by European Council Directive 96/29/Euratom of 13 May 1996. This directive requires that at any point 10 cm from the outer surface of the apparatus, the dose-rate should not exceed 1 μSv/h (0,1 mR/h) taking account of the background level.

*A picture is considered to be intelligible if the following conditions are met:*

- a scanning amplitude of at least 70 % of the usable screen width;*
- a minimum luminance of 50 cd/m<sup>2</sup> with locked blank raster provided by a test generator;*
- a horizontal resolution corresponding to at least 1,5 MHz in the centre, with a similar vertical degradation; and*
- not more than one flashover per 5 min.*

### **6.2 Laser radiation**

An apparatus containing a LASER SYSTEM shall be so constructed that personal protection against laser radiation is provided under normal operating conditions and under fault conditions.

An apparatus containing a LASER SYSTEM is exempt from all further requirements of 6.2 if:

- classification by the manufacturer according to IEC 60825-1:2007, Clauses 3, 8 and 9 shows that the approachable emission level does not exceed class 1 under all conditions of operation, maintenance, service and failure, and
- it does not contain an embedded LASER according to IEC 60825-1.

NOTE 1 The term "approachable emission level" denotes "accessible emission limit (AEL)" in the sense of IEC 60825-1.

Apparatus shall be classified and labelled in accordance with the approachable emission level measured under fault conditions, except that for apparatus not exceeding class 1, 5.2 of IEC 60825-1:2007, does not apply.

*All controls adjustable from the outside BY HAND or any object such as a tool or a coin, and those internal adjustments or pre-sets which are not locked in a reliable manner, are adjusted so as to give maximum radiation.*

NOTE 2 Soldered joints and paint locking are examples of adequate locking.

The laser radiation emitted by redirection as mentioned in IEC 60825-1:2007, 3.37 b), shall not be measured for a LASER SYSTEM of class 1.

*Compliance is met by satisfying the relevant requirements as specified in IEC 60825-1 with the following modifications and additions:*

*Normal operating conditions:*

- a) *The apparatus shall meet under normal operating conditions, the approachable emission limits of class 1 as specified in IEC 60825-1:2007, Tables 4 and 5. Time basis of the classification is 100 s.*

*Compliance is checked by performing the relevant measurements as specified in Clause 9 of IEC 60825-1:2007.*

- b) *If the apparatus incorporates a LASER SYSTEM which meets, under normal operating conditions, the approachable emission limits of class 1, the requirements mentioned under c) and d) do not apply.*

- c) *Adequate measures shall be taken to prevent the opening of any cover BY HAND giving access to laser radiation in excess of class 1 limits.*

*Compliance is checked by inspection and measurement.*

- d) *Where safety is dependent on the proper functioning of a mechanical SAFETY INTERLOCK, this interlock shall be fail-safe (in the failure mode the apparatus is rendered inoperative or non-hazardous), or shall withstand a switching test of 50 000 cycles of operation with current and voltage applied as under normal operating conditions.*

*Compliance is checked by inspection or test.*

*Single fault conditions:*

- a) *When the apparatus is operated under fault conditions as specified in 4.3, the approachable emission level from the apparatus shall be not higher than class 3R outside the wavelength range of 400 nm to 700 nm and not higher than five times the limit for class 1 within the wavelength range of 400 nm to 700 nm.*

NOTE The class 3R limits are as specified in IEC 60825-1, Tables 7 and 8.

*Compliance is checked by performing the relevant measurements as specified in Clause 9 of IEC 60825-1:2007.*

- b) *If the apparatus incorporates a LASER SYSTEM which meets, under fault conditions, the approachable emission limits given in a), the requirements mentioned under c) and d) do not apply.*

- c) Adequate measures shall be taken to prevent the opening of any cover BY HAND giving access to laser radiation in excess of the limits given in a).

*Compliance is checked by inspection and measurement.*

- d) Where safety is dependent on the proper functioning of a mechanical SAFETY INTERLOCK, this interlock shall be fail-safe (in the failure mode the apparatus is rendered inoperative or non-hazardous), or shall withstand a switching test of 50 000 cycles of operation with current and voltage applied as under normal operating conditions.

*Compliance is checked by inspection or test.*

### **6.3 Light emitting diodes (LEDs)**

Equipment containing LEDs that produce optical radiation within the Risk Group 3 limits specified in IEC 62471 in a wavelength range 200 nm to 3 000 nm, as specified by the lamp manufacturer, shall be provided with means (such as an interlock, barriers, guards or the equivalent) to reduce the likelihood of the Risk Group 3 optical radiation from appearing in USER ACCESSIBLE areas. Low power applications of LEDs need not comply with IEC 62471.

NOTE 1 Some examples of low power applications of LEDs that will normally comply are those used as:

- indicating lights;
- infra-red devices such as are used in home entertainment devices;
- infra-red devices for data transmission, such as are used between computers and computer peripherals;
- optocouplers; and
- other similar low power devices.

*Compliance is checked by evaluation of available data sheets, by inspection and, if necessary, by measurement.*

NOTE 2 For guidance on measuring techniques, see IEC 62471.

NOTE 3 If optical radiation is broadband visible and IR-A radiation and the luminance of the source does not exceed  $10^4$  cd/m<sup>2</sup>, it is expected that the radiation does not exceed the exposure limits given in 4.3 of IEC 62471:2006 (see 4.1 of IEC 62471:2006).

## **7 Heating under normal operating conditions**

### **7.1 General**

#### **7.1.1 Requirements**

During intended use, no part of the apparatus shall attain an excessive temperature.

*Compliance is checked by measuring the temperature rises under normal operating conditions when a steady state has been attained.*

NOTE 1 In general, a steady state is assumed to be attained after 4 h of operation.

*Temperature rises are determined:*

- in the case of winding wires, by the change in resistance method or any other method giving the average temperature of the winding wires. Care should be taken to ensure that during the measurement of the resistance of winding wires, the influence of circuits or loads connected to these winding wires is negligible; and
- in other cases, by any suitable method.

*Temperature rises shall not exceed the values specified in 7.1.2 to 7.1.6 inclusive.*

*Any single protective device or component of a protective circuit operating during the test shall be defeated, except for:*

- a) THERMAL CUT-OUTS with automatic reset complying with 14.6.2; and
- b) PTC THERMISTORS complying with 14.6.4.

Consequently, if continuous operation of an AUDIO AMPLIFIER is not possible, the amplifier shall also be operated at the maximum possible signal level permitting continuous operation.

#### 7.1.2 ACCESSIBLE parts

The temperature rise of ACCESSIBLE parts shall not exceed the values given in Table 3, item a), "Normal operating conditions".

#### 7.1.3 Parts, other than windings, providing electrical insulation

The temperature rise of insulating parts, other than windings, providing BASIC INSULATION, SUPPLEMENTARY INSULATION, or REINFORCED INSULATION, and of insulating parts, the failure of which would cause an infringement of the requirements of 9.1.1 or a fire hazard, shall not exceed the values given in Table 3, item b) "Normal operating conditions", taking into account condition d) of Table 3.

*If an insulating part is used to establish a CLEARANCE or to contribute to a CREEPAGE DISTANCE and its permissible temperature rise is exceeded, then the relevant area of the insulating part is disregarded when compliance with Clause 8 and Clause 11 is checked.*

#### 7.1.4 Parts acting as a support or a mechanical barrier

The temperature rise of parts, a mechanical failure of which would cause an infringement of the requirements of 9.1.1, shall not exceed the value given in Table 3, item c) "Normal operating conditions".

#### 7.1.5 Windings

The temperature rise of windings comprising insulation providing protection against electric shock or fire hazard shall not exceed the values given in Table 3, items b) and d) "Normal operating conditions".

*If an insulating part is used to establish a CLEARANCE or to contribute to a CREEPAGE DISTANCE and its permissible temperature rise is exceeded, then the relevant area of the insulating part is disregarded when compliance with Clause 8 and Clause 11 is checked.*

NOTE If the insulation is incorporated in a winding in such a way that its temperature rise cannot be measured directly, the temperature is assumed to be the same as that of the winding wire.

#### 7.1.6 Parts not subject to a limit under 7.1.2 to 7.1.5 inclusive

According to the nature of the material, the temperature rise of the part shall not exceed the values given in Table 3, item e), "Normal operating conditions".

Table 3 – Permissible temperature rise of parts of the apparatus (1 of 2)

Parts of the apparatus	Normal operating conditions <sup>a</sup> K	Fault conditions <sup>a</sup> K
a) <i>ACCESSIBLE parts</i>		
Knobs, handles, etc. if		
– metallic	30	65
– non-metallic <sup>c</sup>	50	65
Enclosures if		
– metallic <sup>b</sup>	40	65
– non-metallic <sup>b, c</sup>	60	65
b) <i>Parts providing electrical insulation<sup>d</sup></i>		
Supply cords and wiring insulation with		
– polyvinyl chloride or synthetic rubber		
• not under mechanical stress	60	100
• under mechanical stress	45	100
– natural rubber	45	100
Other insulations of:		
– thermoplastic materials <sup>e</sup>	f	f
– non-impregnated paper	55	70
– non-impregnated cardboard	60	80
– impregnated cotton, silk, paper and textile	70	90
– laminates based on cellulose or textile, bonded with		
• phenol-formaldehyde, melamine-formaldehyde, phenol-furfural or polyester	85	110
• epoxy	120	150
– mouldings of		
• phenol-formaldehyde or phenol-furfural, melamine and melamine phenolic compounds with		
– cellulose fillers	100	130
– mineral fillers	110	150
• thermosetting polyester with mineral fillers	95	150
• alkyd with mineral fillers	95	150
– composite materials of		
• polyester with glass-fibre reinforcement	95	150
• epoxy with glass-fibre reinforcement	95	150
– silicone rubber	100	150
	145	190
c) <i>Parts acting as a support or a mechanical barrier including the inside of enclosures<sup>d</sup></i>		
Wood and WOOD-BASED MATERIALS	60	90
Thermoplastic materials <sup>e</sup>	f	f
Other materials	d	d
d) <i>Winding wires<sup>d, g</sup></i>		
– insulated with		
• non-impregnated silk, cotton, etc.	55	75
• impregnated silk, cotton, etc.	70	100
• oleoresinous materials	70	135
• polyvinyl-formaldehyde or polyurethane resins	85	150
• polyester resins	120	155
• polyesterimide resins	145	180
e) <i>Other parts</i>		
These temperature rises apply to parts not covered by items a), b), c) and d):		
Parts of wood and WOOD-BASED MATERIAL	60	140
Lithium batteries	40 <sup>h</sup>	50 <sup>l</sup>
Resistors and parts of metal, glass, ceramic, etc.	No limit	No limit
All other parts	200	300

For conditions, see the following page.

Table 3 (2 of 2)

Conditions applicable to Table 3

<sup>a</sup> For tropical climates, permissible temperature rises of 10 K less than those specified in this table are required.

The values of the temperature rises are based on a maximum ambient temperature of 35 °C for moderate climates and of 45 °C for tropical climates.

Where the temperatures are thermostatically limited by a THERMAL CUT-OUT with automatic reset or a PTC THERMISTOR, the measured temperature on the part shall not exceed 35 °C plus the permitted rise of Table 3.

<sup>b</sup> For parts not likely to be touched during intended use, temperature rises up to 65 K are allowed under normal operating conditions. The wooden test box of 4.1.4 shall not be used when evaluating access to parts likely to be touched. The following parts are considered not likely to be touched:

- the rear and bottom panels, except those incorporating switches or controls handled during normal use,
- the external heatsinks and metallic parts directly covering external heatsinks, except those on surfaces incorporating switches or controls handled during normal use, and
- the parts of the top surface which are more than 30 mm below the general plane of the top surface.

For outside parts of metal which are covered with plastic material, the thickness of which is at least 0,3 mm, a temperature rise which corresponds to the permissible temperature rise of the insulating material is allowed.

The 65 K rise limit may be applied to the enclosure covering an internal heatsink, if:

- the symbol (IEC 60417-5041 (2002-10)) is marked on or adjacent to the heated area of the surface of the enclosure, and
- the minimum distance over the surface of the product between this area and any control intended to be operated during use is 150 mm or greater, and
- the instruction manual gives information regarding the heated area.

<sup>c</sup> If these temperature rises are higher than those allowed by the class of the relevant insulating material, the nature of the material is the governing factor.

<sup>d</sup> For the purpose of this standard, the permissible temperature rises are based on service experience in relation to the thermal stability of the materials. The materials quoted are examples. For materials for which higher temperature limits are claimed, and for materials other than those listed, the maximum temperatures shall not exceed those which have been proved to be satisfactory, for example in accordance with IEC 60085.

<sup>e</sup> Natural rubber and synthetic rubbers are not considered as being thermoplastic materials.

<sup>f</sup> Due to their wide variety, it is not possible to specify a generic permissible temperature rise for thermoplastic materials. In order to determine the softening temperature of a specific thermoplastic material, the Vicat softening temperature data from the material manufacturer, or, as determined by the test B50 of ISO 306 shall be used. If the material is not known or if the actual temperature of the parts exceeds the softening temperature, the test described under 1) shall be used.

1) the softening temperature of the material is determined on a separate specimen, under the conditions specified in ISO 306 with a heating rate of 50 °C/h and modified as follows:

- the depth of penetration is 0,1 mm; and
- the total thrust of 10 N is applied before the dial gauge is set to zero or its initial reading noted.

2) the temperature limits to be considered for determining the temperature rises are:

- for normal operating conditions, a temperature of 10 K below the softening temperature; and
- for fault conditions, the softening temperature itself.

If the required softening temperature exceeds 120 °C, condition <sup>c</sup> shall be taken into account.

<sup>g</sup> For switch mode transformers temperature rises may be measured with a thermocouple placed as close as practicable to the winding. The permitted temperature rise shall be 10 K less than that given in Table 3.

<sup>h</sup> Lithium batteries shall meet the permissible temperature rise, unless such batteries comply with the applicable electrical tests of IEC 60086-4.

<sup>i</sup> Lithium batteries shall meet the permissible temperature rise, unless such batteries comply with all electrical tests of IEC 60086-4.

## **7.2 Heat resistance of insulating material**

Insulating material supporting parts CONDUCTIVELY CONNECTED TO THE MAINS shall be resistant to heat if, during intended use, these parts carry a steady-state current exceeding 0,2 A and can generate substantial heat due to imperfect contact.

*Compliance is checked by subjecting the insulating material to the test specified in Table 3, condition f or by a review of data from the material manufacturer.*

*The softening temperature of the insulating material shall be at least 150 °C.*

*In those cases where two groups of conductors, each supported by insulating parts, can be rigidly connected or joined together, for example by plug and socket, only one of the insulating parts need meet the test. Where one of the insulating parts is fixed in the apparatus, this part shall meet the test.*

NOTE 1 Examples of parts which can generate substantial heat during intended use are contacts of switches and of voltage setting devices, screw TERMINALS and fuse holders.

NOTE 2 This test need not be performed on parts which are in accordance with a relevant IEC standard.

## **8 Constructional requirements with regard to the protection against electric shock**

**8.1** Conductive parts, covered only by lacquer, solvent-based enamel, ordinary paper, untreated textile, oxide films or beads are considered to be bare.

*Compliance is checked by inspection.*

**8.2** The apparatus shall be designed and constructed so that operations BY HAND, such as

- changing the setting for the voltage or nature of supply;
- replacing fuses and indicator lights; and
- handling of drawers etc.,

does not involve a risk of electric shock.

*Compliance is checked by application of the tests of 9.1.1.*

**8.3** The insulation of HAZARDOUS LIVE parts shall not be provided by hygroscopic materials.

*Compliance is checked by inspection and, in case of doubt, by the following test.*

*A specimen of the material, as specified in Clause 9 of IEC 60167:1964, is subjected to a temperature of  $(40 \pm 2)$  °C, and a relative humidity of 90 % to 95 %, the conditioning period being:*

- 7 days (168 h) for apparatus to be used under tropical conditions;
- 4 days (96 h) for other apparatus.

*Within 1 min after this preconditioning, the specimen shall withstand the tests of 10.4 without the humidity treatment according to 10.3.*

**8.4** The apparatus shall be so constructed that there is no risk of an electric shock from ACCESSIBLE parts or from those parts rendered ACCESSIBLE following the removal BY HAND of a cover.

This requirement applies also to internal parts of battery compartments which become ACCESSIBLE by the removal of a cover when replacing the batteries.

This requirement does not apply to battery compartments inside the apparatus, where the replacement of their batteries by the USER is not intended, for example batteries for memories.

*Compliance is met by satisfying the requirements of 8.5 or 8.6.*

NOTE Inaccessible contacts of TERMINALS are regarded as ACCESSIBLE parts, unless marked with the symbol according to 5.3 b) or intended to connect the apparatus to the MAINS or to provide MAINS power to other apparatus.

**8.5** For CLASS I apparatus, the ACCESSIBLE conductive parts, except for those parts of the apparatus which have DOUBLE or REINFORCED INSULATION (CLASS II construction), shall be separated from HAZARDOUS LIVE parts by BASIC INSULATION meeting the insulation requirements as specified in Clause 10 and the requirements for CLEARANCES and CREEPAGE DISTANCES as specified in Clause 13.

This requirement does not apply to insulations whose short-circuiting does not cause any electric shock hazard.

NOTE 1 For example, if one end of a secondary winding of a SEPARATING TRANSFORMER is connected to an ACCESSIBLE conductive part, the other end need not meet any special insulation requirement with regard to the same ACCESSIBLE conductive part.

A resistor bridging BASIC INSULATION, DOUBLE INSULATION or REINFORCED INSULATION shall comply with the requirements as specified in 14.2 a).

A capacitor or RC-unit bridging BASIC INSULATION between a HAZARDOUS LIVE part and an ACCESSIBLE conductive part connected to the PROTECTIVE EARTHING TERMINAL, shall comply with the requirements of 14.3.2 a).

Such resistors, capacitors or RC-units shall be positioned inside the enclosure of the apparatus.

CLASS I apparatus shall be provided with a PROTECTIVE EARTHING TERMINAL or contact to which the protective earthing contacts of socket-outlets, if any, and ACCESSIBLE conductive parts shall be reliably connected. Such connection is not necessary for those ACCESSIBLE conductive parts which are insulated from HAZARDOUS LIVE parts by DOUBLE or REINFORCED INSULATION (CLASS II construction) or those which are protected from becoming HAZARDOUS LIVE by a conductive part reliably connected to the PROTECTIVE EARTHING TERMINAL.

NOTE 2 Examples of such a conductive part are a metal screen in a transformer between the primary and the secondary windings, a metal chassis, etc.

*Compliance is checked by inspection.*

**8.6** For CLASS II apparatus, the ACCESSIBLE parts shall be separated from HAZARDOUS LIVE parts either by DOUBLE INSULATION specified under item a) or by REINFORCED INSULATION specified under item b).

This requirement does not apply to insulations whose short-circuiting does not cause any electric shock hazard.

EXAMPLE If one end of a secondary winding of a SEPARATING TRANSFORMER is connected to an ACCESSIBLE conductive part, the other end need not meet any special insulation requirement with regard to the same ACCESSIBLE conductive part.

- a) If ACCESSIBLE parts are separated from HAZARDOUS LIVE parts by BASIC and SUPPLEMENTARY INSULATION, the following shall apply:

Each of these insulations shall comply with the insulation requirements as specified in Clause 10 and with the requirements for CLEARANCES and CREEPAGE DISTANCES specified in Clause 13.

Enclosures of wood not complying with the requirements of 8.3 are permitted as SUPPLEMENTARY INSULATION if they withstand the dielectric strength test of 10.4.

*Compliance is checked by inspection and/or measurement.*

- b) If ACCESSIBLE parts are separated from HAZARDOUS LIVE parts by REINFORCED INSULATION the following shall apply:

The insulation shall comply with the insulation requirements specified in Clause 10. Moreover, it shall comply with the requirements for CLEARANCES and CREEPAGE DISTANCES specified in Clause 13.

NOTE An example of assessment of REINFORCED INSULATION is given in Figure 2.

*Compliance is checked by inspection and/or measurement.*

- 8.7** Components complying with the requirements of 14.4.5.3 may bridge BASIC INSULATION only.

All other components complying with the requirements of 14.2 a) or 14.4 may bridge BASIC, SUPPLEMENTARY, DOUBLE or REINFORCED INSULATION.

BASIC and SUPPLEMENTARY INSULATIONS may each be bridged by a capacitor or RC-unit, having the same rated values, complying with the requirements of 14.3.2 a).

DOUBLE or REINFORCED INSULATION may be bridged by:

- two capacitors or RC-units in series, having the same rated values, each complying with the requirements of 14.3.2 a); or
- a single capacitor or RC-unit complying with the requirements of 14.3.2 b).

NOTE For external insulation, bridging DOUBLE or REINFORCED INSULATION, also see 8.8.

Such resistors, capacitors or RC-units shall be positioned inside the enclosure of the apparatus.

*Compliance is checked by inspection.*

- 8.8** BASIC, SUPPLEMENTARY and REINFORCED INSULATION shall each withstand the dielectric strength test as specified in 10.4.

For DOUBLE INSULATION either the BASIC or the SUPPLEMENTARY INSULATION shall have a thickness of at least 0,4 mm.

REINFORCED INSULATION shall have a minimum thickness of 0,4 mm when not subject to any mechanical stress which, at the temperatures during normal operating conditions and under fault conditions, would be likely to lead to deformation or deterioration of the insulating material.

Under mechanical stress conditions, the thickness may have to be increased to comply with the insulation requirements as specified in Clause 10 and the mechanical strength requirements as specified in Clause 12.

The above requirements are not applicable to insulation in thin sheet materials irrespective of their thickness provided that

- it is used within the enclosure of the apparatus, and
- BASIC or SUPPLEMENTARY INSULATION comprises at least two layers of material, each of which will pass the dielectric strength test specified in 10.4 for BASIC or SUPPLEMENTARY INSULATION, or
- BASIC or SUPPLEMENTARY INSULATION comprises three layers of material for which all combinations of two layers together pass the dielectric strength test specified in 10.4 for BASIC or SUPPLEMENTARY INSULATION, or
- REINFORCED INSULATION comprises at least two layers of material, each of which will pass the dielectric strength test specified in 10.4 for REINFORCED INSULATION, or
- REINFORCED INSULATION comprises three layers of insulation material for which all combinations of two layers together pass the dielectric strength test specified in 10.4 for REINFORCED INSULATION.

There is no requirement for all layers of insulation to be of the same insulating material.

For requirements for insulated winding wires for use without additional interleaved insulation, see 8.16.

For test specifications of non-separable thin sheet insulation, see 8.21.

NOTE The purpose of the tests in 8.21 is to ensure that the material has adequate strength to resist damage when hidden in inner layers of insulation. Therefore, the tests are not applied to insulation in two layers. The tests are also not applied to SUPPLEMENTARY INSULATION.

*Compliance is checked by inspection and measurement.*

**8.9** The insulation of internal wiring between HAZARDOUS LIVE conductors in wires or cables and ACCESSIBLE parts, or between HAZARDOUS LIVE parts and conductors in wires or cables connected to ACCESSIBLE conductive parts, shall have a thickness of at least 0,4 mm if made of polyvinyl chloride. Other materials are allowed provided that they withstand the dielectric strength test specified in 10.4 and that their thickness ensures an equivalent mechanical strength, where the construction so requires.

NOTE For example, a polytetrafluoroethylene (PTFE) insulation having a thickness of at least 0,24 mm is considered to fulfil this requirement.

*Compliance is checked by inspection and measurement.*

**8.10** In CLASS II apparatus, DOUBLE INSULATION shall be provided between

- ACCESSIBLE parts and conductors in wires or cables CONDUCTIVELY CONNECTED TO THE MAINS, and
- conductors in wires or cables connected to ACCESSIBLE conductive parts and parts CONDUCTIVELY CONNECTED TO THE MAINS.

Either the BASIC INSULATION or the SUPPLEMENTARY INSULATION shall comply with the requirements of 8.9. The other insulation shall withstand the dielectric strength test specified in 10.4 for BASIC INSULATION or SUPPLEMENTARY INSULATION.

If DOUBLE INSULATION consists of two layers which cannot be tested separately, it shall withstand the dielectric strength test specified in 10.4 for REINFORCED INSULATION.

The test voltage of 10.4 is applied between the conductor and metal foil wrapped tightly around the insulation of the wire over a length of 10 cm.

In the case of insulating sleeves, the test voltage of 10.4 is applied between a tight-fitting metal rod inserted into the sleeve and a metal foil wrapped tightly around the sleeve over a length of 10 cm.

*Compliance is checked by inspection and measurement.*

**8.11** The construction of the apparatus shall be such that, should any wire become detached, the CLEARANCES and CREEPAGE DISTANCES are not reduced below the values specified in Clause 13 by the natural movement of a detached wire. This requirement does not apply if there is no risk of a wire becoming detached.

NOTE 1 It is assumed that not more than one connection will become detached at the same time.

*Compliance is checked by inspection and measurement.*

NOTE 2 Examples of methods deemed to prevent a wire from becoming detached are:

- a) the conductor of the wire is anchored to the tag before soldering, unless breakage close to the soldering place is likely to occur as a result of vibration;
- b) wires are twisted together in a reliable manner;
- c) wires are fastened together reliably by cable ties, adhesive tapes with thermosetting adhesives according to the IEC 60454 series, sleeves or the like;
- d) the conductor of the wire is inserted into a hole in a PRINTED BOARD before soldering, the hole having a diameter slightly greater than that of the conductor, unless breakage close to the PRINTED BOARD is likely to occur as a result of vibration;
- e) the conductor of the wire and its insulation, if any, are securely wrapped around the termination by means of a special tool;
- f) the conductor of the wire and its insulation, if any, are crimped to the termination by means of a special tool.

*In case of doubt, the vibration test of 12.1.3 is carried out to verify compliance.*

**8.12** Windows, lenses, signal lamp covers, etc. shall be fastened by positive means if HAZARDOUS LIVE parts are rendered ACCESSIBLE by their absence.

NOTE Friction only is not regarded as a positive means.

*Compliance is checked by inspection and, in case of doubt, by applying a force from the outside of 20 N for 10 s at the most unfavourable place and in the most unfavourable direction.*

**8.13** Covers which may be subjected to forces during intended use, for example covers supporting TERMINALS (see Clause 15) shall be fastened by positive means if HAZARDOUS LIVE parts are rendered ACCESSIBLE by their absence.

NOTE Friction only is not regarded as a positive means.

*Compliance is checked by inspection and, in case of doubt, by applying a force of 50 N for 10 s at the most unfavourable place and in the most unfavourable direction.*

*After the tests of 8.12 and 8.13, the apparatus shall show no damage in the sense of this standard; in particular no HAZARDOUS LIVE parts shall become ACCESSIBLE.*

**8.14** Internal wiring of the apparatus, damage to the insulation of which is liable to cause a hazard in the sense of this standard, shall

- be secured so as not to contact parts exceeding the permissible temperature rise for the insulation of the wires as specified in Table 3 when a force of 2 N is applied to any part of the wiring or their surroundings, and
- be so constructed that there is no risk of damage to the insulation of the wires, for example by sharp edges, moving parts or pinches, which may come into contact with other parts of the apparatus, when a force of 2 N is applied to any part of the wiring or their surroundings.

*Compliance is checked by inspection and measurement.*

**8.15** Apparatus designed to be supplied exclusively by a SUPPLY APPARATUS specified by the manufacturer of the apparatus, shall be so constructed that the SPECIAL SUPPLY APPARATUS cannot be replaced, without modification, by a SUPPLY APPARATUS FOR GENERAL USE.

NOTE The required non-interchangeability can be obtained for example by special connections.

*Compliance is checked by inspection.*

**8.16** Insulated winding wires of wound components, the insulation of which is providing BASIC INSULATION, SUPPLEMENTARY INSULATION, REINFORCED INSULATION or DOUBLE INSULATION shall meet the following requirements:

- where the insulation on the winding wire is used to provide BASIC INSULATION, SUPPLEMENTARY INSULATION or REINFORCED INSULATION in a wound component, the insulated wire shall comply with Annex H;
- the minimum number of constructional layers applied to the conductor or conductors shall be as follows:
  - for BASIC INSULATION: two wrapped layers or one extruded layer;
  - for SUPPLEMENTARY INSULATION: two layers, wrapped or extruded;
  - for REINFORCED INSULATION: three layers, wrapped or extruded.
- where more than one constructional layer is specified above, it is permitted for the total number of layers to be on one conductor or shared between the two conductors;
- the insulated winding wires that are adjacent to each other are considered to be separated by DOUBLE INSULATION if the insulation of each conductor is rated for the WORKING VOLTAGE;
- if the wire is insulated with two or more spirally wrapped layers of tape, the overlap of layers shall be adequate to ensure continued overlap during manufacture of the wound component. Layers of tape shall be sealed if CREEPAGE DISTANCES between layers, as wrapped, do not fulfil Clause 13 of this standard;

NOTE For wires insulated by an extrusion process, sealing is inherent to the process.

- where two insulated wires or one bare and one insulated wire are in contact inside a wound component, crossing each other at an angle between 45° and 90° and subject to winding tension, protection against mechanical stress shall be provided. The protection can be achieved by one of the following:
  - physical separation in the form of insulating sleeving or sheet material or using double the required number of insulation layers, or
  - the wound component meets the requirements of 8.17.
- the manufacturer shall demonstrate that the wire has been subjected to 100 % routine dielectric strength test as specified in Clause H.3.

*Compliance is checked by inspection of the part and of the declaration by the manufacturer of the winding wire.*

**8.17** Where required by 8.16, the wound component is subjected to the following cycling test, each cycle consisting of a heat run, a vibration test and a moisture treatment. Measurements according to 8.17 d) are made before the cycling test and after each cycle.

*The number of specimens is 3. The specimens are subjected to 10 test cycles.*

a) *Heat run*

*Depending on the type of insulation (thermal classification), the specimens are kept in a heating cabinet for a combination of time and temperature as specified in Table 4. The 10 cycles are carried out with the same combination.*

*The temperature in the heating cabinet shall be maintained within a tolerance of  $\pm 3$  °C.*

**Table 4 – Test temperature and testing time (in days) per cycle**

Test temperature °C	Temperature for the insulation system °C				
	100	115	120	140	165
220					4
210					7
200					14
190				4	
180				7	
170				14	
160			4		
150		4	7		
140		7			
130	4				
120	7				
Corresponding classification according to IEC 60085 and IEC 60216	A	E	B	F	H
The manufacturer decides which combination of time and temperature shall be used for the test.					

After the heat tests, the specimens are allowed to cool down to ambient temperature before the vibration test is made.

b) *Vibration test*

Specimens are fastened to the vibration generator in their normal position of use, as specified in IEC 60068-2-6, by means of screws, clamps or straps round the component. The direction of vibration is vertical, and the severity is:

- duration: 30 min;
- amplitude: 0,35 mm;
- frequency range: 10 Hz, ...55 Hz, ...10 Hz;
- sweep rate: approximately one octave per minute.

c) *Moisture treatment*

The specimens are submitted for two days to the moisture treatment of 10.3.

d) *Measurements*

After each cycle, the insulation resistance is measured and the dielectric strength test is carried out according to 10.4. In addition, the following test is made for transformers operating at MAINS frequency only:

After the dielectric strength test, one input circuit is connected to a voltage equal to a test voltage of at least 1,2 times the RATED SUPPLY VOLTAGE, at double the rated frequency for 5 min. No load is connected to the transformer. During the test, polyfilar windings, if any, are connected in series.

A higher test frequency may be used; the duration of the period of connection, in minutes, then being equal to 10 times the rated frequency divided by the test frequency, but not less than 2 min.

During this test, there shall be no breakdown of the insulation between the turns of a winding, between input and output circuits, between adjacent input or output circuits, or between the windings and any conductive core.

The values of the test voltage for the dielectric test according to 10.4 are reduced to 35 % of the specified values and the testing times doubled.

A specimen is considered not to pass the test if the no-load current or the in-phase component of the no-load input current is at least 30 % greater than the corresponding value, obtained during the initial measurement.

*If, after the completion of all 10 cycles, one or more specimens have failed, the transformer is considered as not complying with the endurance test.*

**8.18** If the apparatus is designed to be fed from the MAINS, a disconnect device shall be provided to isolate the apparatus from the MAINS for servicing.

NOTE The following are examples of disconnect devices:

- the MAINS plug,
- an appliance coupler,
- an all-pole MAINS SWITCH,
- an all-pole circuit breaker.

Where the MAINS plug or appliance coupler is used as the disconnect device, instructions for use shall comply with 5.5.3 a).

Where an all-pole MAINS SWITCH or an all pole circuit breaker is used as the disconnect device, it shall have contact separation of at least 3 mm in each pole and shall disconnect all poles simultaneously.

*Compliance is checked by inspection and measurement.*

For apparatus on which a MAINS SWITCH is used as a disconnect device, the on-position of the switch shall be indicated.

EXAMPLES Marking, illumination, audible indication or other suitable means are considered a typical form of indication of the on-position.

Where the indication is in the form of marking, the relevant requirements of 5.5.3 shall be complied with.

*Compliance is checked by inspection.*

**8.19** A MAINS SWITCH shall not be fitted in the MAINS flexible cable or cord.

NOTE Additional requirements for switches are given in 14.7.

*Compliance is checked by inspection.*

**8.20** Where resistors, capacitors or RC-units are used for bridging contact gaps of switches CONDUCTIVELY CONNECTED TO THE MAINS, the components shall comply with 14.2 a) or 14.3.3 respectively.

*Compliance is checked by inspection.*

**8.21** *Non-separable thin sheet material shall comply with 26.3 of IEC 61558-1:2009 or with the following:*

*Three test samples, each individual sample consisting of three or more layers of non-separable thin sheet material forming REINFORCED INSULATION, are used. One sample at a time is fixed to the mandrel of the test fixture (Figure 14) as shown in Figure 15.*

*A downward force of  $150\text{ N} \pm 10\text{ N}$  is applied to the free end of the sample (see Figure 16), using an appropriate clamping device. The mandrel is rotated BY HAND without jerks*

- *from the initial position (Figure 15) to the final position (Figure 16) and back;*
- *as above for the second time;*
- *from the initial position to the final position.*

*If a sample breaks during rotation where it is fixed to the mandrel or the clamping device, this does not constitute a failure and the test is repeated on a fresh sample. If a sample breaks at any other place, the test has failed.*

*After this preconditioning, a sheet of metal foil, 0,035 mm  $\pm$  0,005 mm thick, at least 200 mm long, is placed along the surface of the sample, hanging down on each side of the mandrel (see Figure 16). The surface of the foil in contact with the sample shall be conductive, not oxidised or otherwise insulated. The foil is positioned so that its edges are not less than 18 mm from the edges of the sample (see Figure 17). The foil is then tightened by two equal weights, one at each end, using appropriate clamping devices.*

*While the mandrel is in its final position, and within the 60 s following the final positioning, a dielectric strength test is applied between the mandrel and the metal foil in accordance with 10.4.2, using a test voltage of 1,5 times the value specified in Table 5 for REINFORCED INSULATION, but not less than 5 kV.*

*The entire test procedure is repeated on the other two samples.*

*No flashover or breakdown shall occur during the test; corona effects and similar phenomena being disregarded.*

## **9 Electric shock hazard under normal operating conditions**

### **9.1 Testing on the outside**

#### **9.1.1 General**

##### **9.1.1.1 Requirements**

ACCESSIBLE parts shall not be HAZARDOUS LIVE.

For interconnection with apparatus under the scope of other standards, circuits should comply with 9.1.1 and, depending upon the construction, with 8.5 or 8.6.

In addition, when not connected to another apparatus, inaccessible contacts of TERMINALS shall not be HAZARDOUS LIVE, with the following exceptions:

- contacts of signal output TERMINALS, if they have to be HAZARDOUS LIVE for functional reasons, provided the contacts are separated from the supply source as required according to Clause 8 for ACCESSIBLE conductive parts. Inaccessible input TERMINALS, for example those of loudspeakers, are permitted to be HAZARDOUS LIVE when connected to such output TERMINALS.

NOTE For the marking of such output TERMINALS, see 5.3 b).

- TERMINALS complying with 15.1.1 provided for connecting the apparatus to the MAINS, socket-outlets and contacts of connecting blocks for providing power to other apparatus.

For PROFESSIONAL EQUIPMENT, audio output TERMINALS are permitted to be ACCESSIBLE to SKILLED PERSONS if the audio output voltage, when the apparatus is producing its NON-CLIPPED OUTPUT POWER, is not greater than 120 V r.m.s.

The requirements to determine whether a HAZARDOUS LIVE part is ACCESSIBLE apply only to HAZARDOUS LIVE voltages not exceeding 1 000 V a.c. or 1 500 V d.c. For higher voltages, there shall be a CLEARANCE between the part at HAZARDOUS LIVE voltage and the test finger or the test pin as specified in 13.3.1 for BASIC INSULATION (see Figure 3).

*Compliance is checked by inspection and by measurements according to 9.1.1.2 and tests according to 9.1.1.3.*

#### **9.1.1.2 Determination of HAZARDOUS LIVE parts**

In order to verify that a part or a contact of a TERMINAL is HAZARDOUS LIVE, the following measurements are carried out between any two parts or contacts, then between any part or contact and either pole of the supply source used during the test.

NOTE 1 For discharges between the poles of the MAINS plug, see 9.1.6.

- a) The part or contact of a TERMINAL is HAZARDOUS LIVE if the open-circuit voltage exceeds
- 35 V (peak) a.c. or 60 V d.c.; or
  - 71 V r.m.s. for audio signals of other than PROFESSIONAL APPARATUS; or
  - 120 V r.m.s. for audio signals of PROFESSIONAL APPARATUS.
- b) The part or contact of a TERMINAL is HAZARDOUS LIVE if the TOUCH-CURRENT, expressed as the corresponding voltages  $U_1$  and  $U_2$ , and measured in accordance with IEC 60990 with the measuring network described in Annex D of this standard, exceeds the following values:
- for a.c.:  $U_1 = 35$  V (peak) and  $U_2 = 0,35$  V (peak);
  - for d.c.:  $U_1 = 1,0$  V.

NOTE 2 The limit values of  $U_2 = 0,35$  V (peak) for a.c. and  $U_1 = 1,0$  V for d.c. correspond to the values 0,7 mA (peak) a.c. and 2,0 mA d.c.

The limit value  $U_1 = 35$  V (peak) for a.c. corresponds to the value 70 mA (peak) a.c. for frequencies greater than 100 kHz.

NOTE 3 For apparatus intended to be used in tropical climates, the voltage limits given in a) and b) above are typically halved.

*For CLASS I constructions, the r.m.s. TOUCH-CURRENT to earth shall not be more than 3,5 mA. The measurement shall be carried out with the measurement network described in Annex D of this standard and with the protective earthing connection disconnected.*

*Discharges shall be measured to the TERMINAL provided for connecting the apparatus to the supply source, immediately after the interruption of the supply. The part or contact of a TERMINAL is HAZARDOUS LIVE if:*

- c) *the charge exceeds 45  $\mu$ C for stored charges at voltages between 60 V d.c. and 15 kV d.c., or*
- d) *the energy of discharge exceeds 350 mJ for stored charges at voltages exceeding 15 kV d.c.*

#### **9.1.1.3 Determination of ACCESSIBLE parts**

*In order to determine whether a HAZARDOUS LIVE part is ACCESSIBLE, the jointed test finger according to test probe B of IEC 61032:1997, is pushed against the enclosure or inserted through any openings of the enclosure, including openings in the bottom, without appreciable force.*

*Through openings, the test finger is applied to any depth that the finger will permit and is rotated or angled before, during and after insertion to any position. If the opening does not allow the entry of the finger, the force on the finger in the straight position is increased to 20 N  $\pm$  2 N and the test repeated with the finger in angled position.*

*The test is repeated using small finger probes according to test probes 18 and 19 of IEC 61032:1997. This does not apply if the intended conditions of use prevent the apparatus from being accessed by children.*

*Conductive parts, covered only by lacquer, solvent-based enamel, ordinary paper, untreated textile, oxide films or beads are considered to be bare.*

*Moving parts of loudspeaker systems, such as dust caps or cones of drivers or passive radiators, are not regarded as preventing accessibility.*

NOTE 1 See also 13.3.1.

*For CLASS II constructions, the test probe 13 of IEC 61032:1997 shall not touch HAZARDOUS LIVE parts when applied with a force of  $3\text{ N} \pm 0,3\text{ N}$  in every possible position.*

*The test probe is not applied to socket-outlets, connectors providing MAINS power, fuse holders and the like.*

NOTE 2 For indication of electrical contact, a voltage of not less than 40 V and not more than 50 V in series with a suitable lamp can be used.

### **9.1.2 Shafts of operating knobs, handles, levers and the like**

Shafts of operating knobs, handles, levers and the like shall not be HAZARDOUS LIVE.

*Compliance is checked by inspection, and in case of doubt, by measurement according to 9.1.1.2.*

### **9.1.3 Openings of the enclosure**

The apparatus shall be so designed that suspended foreign bodies cannot become HAZARDOUS LIVE, when introduced through ventilation or other holes.

*Compliance is checked by applying to the holes a metal test pin having a diameter of 4 mm and a length of 100 mm. The test pin is suspended freely from one end; the penetration is limited to the length of the test pin.*

*The test pin shall not become HAZARDOUS LIVE.*

### **9.1.4 TERMINALS**

The use of a single-pole plug or a bare wire to make connection with a contact of a TERMINAL for earth or antenna or for audio, video or associated signals, shall not involve the risk of an electric shock.

The test is not applied to TERMINALS marked with the symbol of 5.3 b).

NOTE See also 15.1.2.

*Compliance is checked by the following tests:*

*Within 25 mm measured from each contact of the TERMINAL, a test pin according to IEC 61032:1997, test probe D, however limited in length to  $20\text{ mm} \pm 0,2\text{ mm}$ , is applied in every possible position, in case of doubt with a force of  $10\text{ N} \pm 1\text{ N}$ .*

*Each contact is tested with a straight test probe according to IEC 61032:1997, test probe D, in case of doubt with a force of  $1\text{ N} \pm 0,1\text{ N}$ .*

*The test probes shall not become HAZARDOUS LIVE.*

#### 9.1.5 Pre-set controls

If a hole giving access to pre-set controls is marked as such on the enclosure or in the instruction for use, and the setting of this control requires a screwdriver or other tool, the adjustment of the control shall not involve the risk of an electric shock.

*Compliance is checked by applying to the opening a test probe according to IEC 61032:1997, test probe C.*

*The test probe is applied in every possible position, in case of doubt with a force of  $10\text{ N} \pm 1\text{ N}$ .*

*The test probe shall not become HAZARDOUS LIVE.*

#### 9.1.6 Withdrawal of MAINS plug

Apparatus intended to be connected to the MAINS by means of a MAINS plug shall be so designed that there is no risk of an electric shock from stored charge on capacitors, when touching the pins or contacts of the plug after its withdrawal from the socket-outlet.

During the measurement below, a bleeder resistor is to be open circuited one at a time unless it complies with the requirements in 14.2.

NOTE For the purpose of 9.1.6, male interconnection couplers and male appliance couplers are regarded as MAINS plugs.

*Compliance is checked by measurement according to 9.1.1.2 a) or c) or by calculation.*

*The MAINS SWITCH, if any, is in the off-position, unless it is more unfavourable in the on-position.*

*Two seconds after withdrawal of the MAINS plug, the pins or contacts of the plug shall not be HAZARDOUS LIVE.*

*The test may be repeated up to 10 times to obtain the most unfavourable situation.*

*If the nominal capacitance across the MAINS poles does not exceed  $0,1\ \mu\text{F}$ , no test is conducted.*

*When conducting the measurement, the measurement is either made with or referred to an instrument having an input impedance consisting of a resistance of  $100\ \text{M}\Omega \pm 5\ \text{M}\Omega$  in parallel with an input capacitance of  $25\ \text{pF}$  or less.*

#### 9.1.7 Resistance to external forces

The enclosure of the apparatus shall be sufficiently resistant to external forces.

*Compliance is checked by the following tests:*

- a) *by means of a rigid test finger according to IEC 61032:1997, test probe 11, a force of  $50\ \text{N} \pm 5\ \text{N}$ , directed inwards, is applied for 10 s to different points of the enclosure including openings and textile coverings.*

*The force shall be so exerted by the tip of the test finger as to avoid wedge or lever action.*

*During the test, the enclosure shall not become HAZARDOUS LIVE, HAZARDOUS LIVE parts shall not become ACCESSIBLE, textile coverings shall not touch HAZARDOUS LIVE parts;*

- b) *by means of a test hook as shown in Figure 4, a force of  $20\ \text{N} \pm 2\ \text{N}$ , directed outwards, is applied for 10 s at all points where this is possible.*

*During the test, HAZARDOUS LIVE parts shall not become ACCESSIBLE;*

- c) *external conductive enclosures and conductive parts of an external enclosure shall be subjected for 5 s to a steady force of  $(250 \pm 10)$  N for floor-standing apparatus or  $(100 \pm 10)$  N for other apparatus, applied to the enclosure or to a part of the enclosure fitted to the apparatus, by means of a suitable test tool providing contact over a circular plane surface 30 mm in diameter.*

NOTE 1 Contacts of TERMINALS are not considered to be a conductive part of the external enclosure.

*After the tests, the apparatus shall show no damage in the sense of this standard.*

NOTE 2 The apparatus need not be connected to the supply source during the tests.

## **9.2 Removal of protective covers**

A part which becomes ACCESSIBLE by the removal of a cover BY HAND shall not be HAZARDOUS LIVE (see also 14.8).

This requirement applies also to internal parts of battery compartments which become ACCESSIBLE by the removal of a cover either BY HAND or with the use of a tool, coin or other object, when replacing the batteries. An exception is made in the case of batteries which are not intended to be replaced by the USER, for example batteries for memories.

This requirement applies also to internal parts of loudspeaker systems that become ACCESSIBLE by the removal of a loudspeaker grille from the outside by the use of a tool, coin or other object.

In such a case, the apparatus shall be marked according to 5.4 b).

*Compliance is checked by inspection and by application of the tests of 9.1.1, except that the measurements are made 2 s after removal of the cover or grille.*

NOTE Any part removable BY HAND of a voltage setting device is considered to be a protective cover.

## **10 Insulation requirements**

### **10.1 Frequencies**

The insulation requirements given in this standard are for frequencies up to 30 kHz. It is permitted to use the same requirements for insulation operating at frequencies over 30 kHz until additional data are available.

NOTE For information on insulation behaviour in relation to frequency, see IEC 60664-1 and IEC 60664-4.

### **10.2 Surge test**

The insulation on CLASS II apparatus between ACCESSIBLE parts or parts connected to them and HAZARDOUS LIVE parts, shall withstand surges due to transients, caused for example by thunderstorms and entering the apparatus through the antenna TERMINAL.

*Compliance is checked by the following test:*

*The insulation between*

- *TERMINALS for the connection of antenna and MAINS supply TERMINALS, and*
- *MAINS supply TERMINALS and any other TERMINAL in case of apparatus providing supply voltages to other apparatus with antenna TERMINALS,*

*is subjected to 50 discharges at a maximum rate of 12/min, from a 1 nF capacitor charged to 10 kV in a test circuit, as shown in Figure 5a.*

*During this test, the apparatus should not be energized.*

*After the test, the tested insulation shall comply with the requirements of 10.4.*

### **10.3 Humidity treatment**

The safety of the apparatus shall not be impaired by humidity conditions which may occur in the intended use.

*Compliance is checked by the humidity treatment described in this subclause 10.3, followed immediately by the tests of 10.4.*

*Cable entries, if any, are left open. If knock-outs are provided, they are opened.*

*Electrical components, covers and other parts which can be removed BY HAND are removed and subjected, if necessary, to the humidity treatment with the main part.*

*The humidity treatment is carried out in a humidity chamber containing air with a relative humidity of  $(93 \pm 3)$  %.*

*The temperature of the air, at all places where the apparatus can be located, is maintained at a temperature between 20 °C and 30 °C but the chosen temperature is to be kept within  $\pm 2$  °C during the test. Apparatus intended to be used in tropical climates are subjected to a temperature of  $(40 \pm 2)$  °C.*

*Before being placed in the chamber, the apparatus is brought to a temperature between the specified temperature and a 4 K higher temperature.*

*The apparatus is kept in the chamber for*

- 5 days (120 h) for apparatus intended to be used in tropical climates,*
- 2 days (48 h) for other apparatus.*

NOTE 1 In most cases, the apparatus can be brought to the specified temperature by keeping it at this temperature for at least 4 h before the humidity treatment.

NOTE 2 The air in the chamber can be stirred and the chamber can be so designed that mist or condensed water will not precipitate on the apparatus.

*During this test, the apparatus should not be energized.*

*After this treatment, the apparatus shall show no damage in the sense of this standard.*

### **10.4 Insulation resistance and dielectric strength**

**10.4.1** The insulation of the insulating materials shall be adequate.

*Compliance is checked in accordance with 10.4.2, and, unless otherwise stated, immediately after the humidity treatment according to 10.3.*

*In order to facilitate dielectric strength testing, components and subassemblies may be tested separately.*

**10.4.2** *The insulations listed in Table 5 shall be tested:*

- for insulation resistance with 500 V d.c.; and*

- for dielectric strength as follows:
  - insulations stressed with d.c. voltage (RIPPLE FREE) are tested with a d.c. voltage; and
  - insulations stressed with a.c. voltage are tested with an a.c. voltage at MAINS frequency.

However, where corona, ionization, charge effects or the like may occur (for example for capacitors), a d.c. test voltage is recommended.

Test voltages shall be as specified in Table 5 for the appropriate grade of insulation (BASIC INSULATION, SUPPLEMENTARY INSULATION or REINFORCED INSULATION) and for the WORKING VOLTAGE *U* across the insulation.

For the purpose of determining the WORKING VOLTAGE *U*, the following applies:

- the apparatus is fed by its RATED SUPPLY VOLTAGE;
- in case of a.c. voltages, the true peak value including periodic and non-periodic superimposed pulses with a half-value time longer than 50 ns shall be measured;
- in case of d.c. voltages, the peak value of any superimposed ripple shall be included;
- periodic and non-periodic transients with a half-value time not exceeding 50 ns shall be disregarded;
- unearthed ACCESSIBLE conductive parts shall be assumed to be connected to an earth TERMINAL or to a PROTECTIVE EARTHING TERMINAL or contact;
- where a transformer winding or other part is floating, i.e. not connected to a circuit which establishes its potential relative to earth, it shall be assumed to be connected to an earth TERMINAL or to a PROTECTIVE EARTHING TERMINAL or contact at the point which results in the highest WORKING VOLTAGE being obtained;
- where DOUBLE INSULATION is used, the WORKING VOLTAGE across the BASIC INSULATION shall be determined by imagining a short-circuit across the SUPPLEMENTARY INSULATION, and vice versa. For insulation between transformer windings, the short-circuit shall be assumed to take place at the point at which the highest WORKING VOLTAGE is produced across the other insulation;
- for insulations between two transformer windings, the highest voltage between any two points in the two windings shall be used, taking into account external voltages to which the windings may be connected; and
- for insulations between a transformer winding and another part, the highest voltage between any point of the winding and the other part shall be used.

Initially, not more than half of the prescribed test voltage is applied, then it is raised rapidly to the full value which is held for 1 min.

The measurements of the insulation resistance and the dielectric strength tests are made in the humidity chamber, or in the room in which the apparatus was brought to the prescribed temperature, after the reassembly of those parts which may have been removed.

The apparatus is deemed to comply with the requirement, if the insulation resistance measured after 1 min is not less than the values given in Table 5 and no flash-over or breakdown occurs during the dielectric strength test.

When testing enclosures of insulating material, a metal foil is pressed tightly against ACCESSIBLE parts.

For apparatus incorporating both REINFORCED INSULATION and lower grades of insulation, care shall be taken that the voltage applied to the REINFORCED INSULATION does not overstress BASIC INSULATION or SUPPLEMENTARY INSULATION.

ACCESSIBLE conductive parts may be connected together during the dielectric strength test.

NOTE 1 An instrument to carry out the dielectric strength test on thin sheets of insulating material is described in Figure 6.

NOTE 2 The test is not made on insulation the short-circuiting of which does not cause any electric shock hazard, for example in the case where one end of a secondary winding of an ISOLATING TRANSFORMER is connected to an ACCESSIBLE conductive part, the other end need not meet any insulation requirement with regard to the same ACCESSIBLE conductive part.

*Resistors, capacitors and RC-units complying with 14.2, 14.3.2 and 14.3.3 respectively, connected in parallel with the insulations to be tested, are disconnected. Inductors and windings which otherwise would prevent the test from being made, are also disconnected.*

**Table 5 – Test voltages for dielectric strength test and values for insulation resistance**

Insulation	Insulation resistance	AC test voltage (peak) or DC test voltage
1 Between parts of different polarity DIRECTLY CONNECTED TO THE MAINS.	2 MΩ	For rated MAINS voltages ≤ 150 V (r.m.s.): 1 410 V For rated MAINS voltages > 150 V (r.m.s.): 2 120 V
2 Between parts separated by BASIC INSULATION or by SUPPLEMENTARY INSULATION.	2 MΩ	Curve A of Figure 7
3 Between parts separated by REINFORCED INSULATION.	4 MΩ	Curve B of Figure 7

NOTE Curves A and B of Figure 7 are defined by the following points:

WORKING VOLTAGE <i>U</i> (peak)	Test voltage (peak)	
	Curve A	Curve B
35 V	707 V	1 410 V
354 V		4 240 V
1 410 V	3 980 V	
10 kV	15 kV	15 kV
> 10 kV	1,5 <i>U</i> V	1,5 <i>U</i> V

## 11 Fault conditions

### 11.1 Electric shock hazard

Protection against electric shock shall still exist when the apparatus is operated under fault conditions.

*Compliance is checked by the tests described in Clause 9, modified as specified below and under fault conditions.*

*For contacts of TERMINALS, the permissible values of 9.1.1.2 are increased to:*

- 70 V (peak) a.c. and 120 V d.c. for other than audio signals, and
- $U_1 = 70$  V (peak) and  $U_2 = 1,4$  V (peak) for a.c. and to  $U_1 = 4$  V for d.c.,

*provided that the connectors for antenna and/or earth cannot be inserted into the TERMINAL under test.*

*The limits under normal operating conditions for audio signals shall not be exceeded under fault conditions.*

NOTE For apparatus intended to be used in tropical climates, the values given above are typically halved.

*If short-circuiting or disconnecting a resistor, a capacitor, an RC-unit, an optocoupler or an inductor causes an infringement of the requirements, the apparatus is still deemed to be satisfactory if the component complies with the relevant requirements of Clause 14 (see 4.3.5).*

*If, during the tests, an insulation mentioned in Table 5 is subjected to a voltage exceeding the voltage occurring under normal operating conditions, and if this increase involves a higher test voltage according to 10.4, this insulation shall withstand a test for dielectric strength at the higher test voltage, unless the higher voltage is due to the short-circuiting or disconnection of a resistor, a capacitor, an RC-unit, an optocoupler or an inductor complying with the relevant requirements of Clause 14.*

## **11.2 Heating**

### **11.2.1 Requirements**

When the apparatus is operated under fault conditions, no part shall reach such a temperature that:

- there is a danger of fire to the surroundings of the apparatus; or
- safety is impaired by abnormal heat developed in the apparatus.

*Compliance is checked by the tests of 11.2.2.*

*During the tests, any flame inside the apparatus shall extinguish within a period of 10 s.*

*During the test, solder may soften or become fluid as long as the apparatus does not become unsafe within the sense of this standard.*

*In addition, solder terminations shall not be used as a protective mechanism with the exception of solder which is intended to melt, for example that of THERMAL LINKS.*

### **11.2.2 Measurement of temperature rises**

*The apparatus is operated under fault conditions and the temperature rises are measured after a steady state has been attained, but not later than after 4 h operation of the apparatus.*

*During this period, the apparatus shall meet the requirements of 11.2.3 up to and including 11.2.8.*

*In the case where an applied fault condition results in the interruption of the current before steady state has been reached, the temperature rises are measured immediately after the interruption*

*If the temperature is limited by a fuse, under a single fault condition:*

- a fuse complying with the IEC 60127 series shall open within 1 s; or
- a fuse not complying with the IEC 60127 series shall open within 1 s for three consecutive times; or
- the fuse shall comply with the following test.

*The fuse is short-circuited and the current that would have passed through the fuse under the relevant single fault condition is measured.*

- *If the fuse current remains less than 2,1 times the current rating of the fuse, the temperatures are measured after a steady state has been attained.*

- *If the current either immediately reaches 2,1 times the current rating of the fuse or more, or reaches this value after a period of time equal to the maximum pre-arcing time for the relevant current through the fuse under consideration, both the fuse and the short-circuit link are removed after an additional time corresponding to the maximum pre-arcing time of the fuse under consideration and the temperatures are measured immediately thereafter.*

*If the fuse resistance influences the current of the relevant circuit, the maximum resistance value of the fuse shall be taken into account when establishing the value of the current.*

NOTE The above test is based on the fusing characteristics specified in IEC 60127, which also gives the information necessary to calculate the maximum resistance value.

*In determining the current through the fuse, consideration should be given to the fact that this current may vary as a function of time. It should therefore be measured as soon as possible after switching on, taking into account any delay time for full operation of the circuit under consideration.*

*If a temperature rise exceeding the value given in Table 3 is due to the short-circuiting of an insulation, the apparatus is not deemed to be unsatisfactory, but this insulation shall withstand a dielectric strength test as described in 10.4.*

*If a temperature rise exceeding the value given in Table 3 is due to the short-circuiting or disconnecting of a resistor, a capacitor, an RC-unit, an optocoupler or an inductor, the apparatus is deemed to be satisfactory if the component complies with the relevant requirements of Clause 14 (see 4.3.5).*

*If a temperature rise exceeding the value given in Table 3 is due to the disconnection of a resistor, the overload test specified in 14.2 b) is repeated on the resistor mounted in the apparatus, including the connections made by the manufacturer. During this test, the connections shall not fail.*

### **11.2.3 ACCESSIBLE parts**

The temperature rise of ACCESSIBLE parts shall not exceed the values given in Table 3, item a) "Fault conditions".

### **11.2.4 Parts, other than windings and PRINTED BOARDS, providing electrical insulation**

The temperature rise of insulating parts other than windings and PRINTED BOARDS, the failure of which would cause an infringement of the requirements of 11.1, 11.2.3 and 11.2.5 shall not exceed the values given in Table 3, item b) "Fault conditions".

If a temperature rise limit is exceeded, and if there is doubt as to whether or not an electric shock hazard exists, a short circuit is applied between the conductive parts concerned and the tests of 11.1 are repeated.

### **11.2.5 Parts acting as a support or a mechanical barrier**

The temperature rise of parts whose mechanical failure may cause an infringement of the requirements of 9.1.1 shall not exceed the values given in Table 3, item c) "Fault conditions".

### **11.2.6 Windings**

The temperature rise of windings shall not exceed the values given in Table 3, items b) and d) "Fault conditions", with the following exceptions.

- If the temperature is limited due to the operation of replaceable or resettable protective devices, the temperature rises may be exceeded until 2 min after the operation of the device.

*In the case of windings providing protection against electric shock or where a fault could result in a fire hazard, the test is carried out three times and the winding is then subjected to the dielectric strength test of 10.4 without the humidity treatment of 10.3, starting within 1 min after the temperature rise measurement.*

*No failure is allowed.*

- If the temperature is limited due to the operation of an integral non-resettable or a non-replaceable protective device or due to the open circuiting of a winding, the temperature rises may be exceeded, but the test shall be carried out three times using new components.

*In the case of windings providing protection against electric shock or where a fault could result in a fire hazard, the winding is then in each case subjected to the dielectric strength test of 10.4 without the humidity treatment of 10.3, starting within 1 min after the temperature rise measurement.*

*No failure is allowed.*

- Higher temperature rises are allowed for windings, provided a failure of their insulation cannot cause an electric shock hazard or a fire hazard and that they are not connected to sources capable of supplying power in excess of 5 W under normal operating conditions.
- If a temperature rise value is exceeded and if there is doubt as to whether or not a hazard exists, the insulation concerned is short-circuited and the tests of 11.1 and 11.2.3 are repeated.

NOTE If the insulation is incorporated in a winding in such a way that its temperature rise cannot be measured directly, the temperature is assumed to be the same as that of the winding wire.

#### **11.2.7 PRINTED BOARDS**

Where a failure would cause an infringement of the requirements of 11.1, 11.2.3 and 11.2.5, the temperature rise on a PRINTED BOARD shall not exceed the values given under "Fault conditions" in Table 3, item b), with the following exceptions.

The temperature rise may exceed the above values by not more than 100 K for a maximum period of 5 min.

For PRINTED BOARDS classified as V-0 according to IEC 60695-11-10, or VTM-0 according to ISO 9773 or tested according to Clause G.1, the temperature rise may exceed:

- a) the values given under "Fault conditions" in Table 3, item b), by not more than 100 K on one or more small areas providing that the total area does not exceed 2 cm<sup>2</sup> for each fault condition and no electric shock hazard is involved; or
- b) for a maximum period of 5 min, the values given under "Fault conditions" in Table 3, item b), up to the temperature rise value given for "other parts" under "Fault conditions" in Table 3, item e), on one or more small areas, providing that the total area does not exceed 2 cm<sup>2</sup> for each fault condition and no electric shock hazard is involved.

*If a temperature rise limit is exceeded and if there is doubt as to whether or not an electric shock hazard exists, a short circuit is applied between the conductive parts concerned and the tests of 11.1 are repeated.*

*If conductors on PRINTED BOARDS are interrupted, peeled or loosened during any test, the apparatus is still deemed to be satisfactory if all of the following conditions are met:*

- *the PRINTED BOARD is classified as V-0 according to IEC 60695-11-10, or VTM-0 according to ISO 9773 or tested according to Clause G.1;*
- *the interruption is not a POTENTIAL IGNITION SOURCE;*
- *the apparatus complies with the requirements of 11.2.7 with the interrupted conductors bridged;*

- *any peeled or loosened conductor does not reduce the CLEARANCES and CREEPAGE DISTANCES between HAZARDOUS LIVE parts and ACCESSIBLE parts below the values specified in Clause 13.*

For CLASS I apparatus, the continuity of any protective earthing connection shall be maintained; loosening or peeling off of such a conductor is not allowed.

#### **11.2.8 Parts not subject to a limit under 11.2.2 to 11.2.7 inclusive**

According to the nature of the material, the temperature rise of the part shall not exceed the values given under “Fault conditions” in Table 3, item e).

## **12 Mechanical strength**

### **12.1 Complete apparatus**

#### **12.1.1 Requirements**

The apparatus shall have adequate mechanical strength and be so constructed as to withstand such handling as may be expected during intended use.

The apparatus shall be so constructed that short-circuiting of insulations between HAZARDOUS LIVE parts and ACCESSIBLE conductive parts or parts conductively connected to those, for example by unintended loosening of screws, is prevented.

*Compliance, except for devices forming a part of the MAINS plug, is checked by the tests of 12.1.2, 12.1.3, 12.1.4, 12.1.5 and 12.1.6.*

NOTE Devices forming a part of the MAINS plug are subjected to the tests as described in 15.4.

#### **12.1.2 Bump test**

*Apparatus with a mass exceeding 7 kg are subjected to the following test.*

*The apparatus is placed on a horizontal wooden support, which is allowed to fall 50 times from a height of 5 cm onto a wooden table.*

*After the test, the apparatus shall show no damage in the sense of this standard.*

#### **12.1.3 Vibration test**

*TRANSPORTABLE APPARATUS intended to be used for audio amplification of musical instruments, PORTABLE APPARATUS and apparatus consisting of an enclosure having at least one metal surface, decorative parts being excluded, are subjected to a vibration endurance conditioning by sweeping, as specified in IEC 60068-2-6.*

*The apparatus is fastened in its intended positions of use to the vibration-generator by means of straps round the enclosure. The direction of vibration is vertical, and the severity is:*

- *Duration* 30 min
- *Amplitude* 0,35 mm
- *Frequency range* 10 Hz ... 55 Hz ... 10 Hz
- *Sweep rate* approximately 1 octave/min.

*After the test, the apparatus shall show no damage in the sense of this standard, in particular, no connection or part the loosening of which might impair safety shall have loosened.*

#### 12.1.4 Impact test

The apparatus is held firmly against a rigid support and is subjected to three blows from a spring-operated impact hammer according to IEC 60068-2-75, applied with a kinetic energy just before impact of 0,5 J to every point of the enclosure that protects dangerous moving parts or HAZARDOUS LIVE parts and is likely to be weak, including ventilation areas, drawers in the pulled-out position, handles, levers, switch knobs and the like, by pressing the release cone perpendicularly to the surface.

This impact hammer test is also made on windows, lenses, signal lamps and their covers, etc., but only if they protrude from the enclosure by more than 5 mm or if the area of the plane projection of the individual surface area exceeds 1 cm<sup>2</sup>.

Moreover, the non-ventilated solid areas of the enclosure that protect HAZARDOUS LIVE parts shall be subjected to a single impact, specified in Table 6.

The impact specified in Table 6 shall be caused by allowing a solid, smooth, steel ball of (50 ± 1) mm in diameter and with the mass of approximately 500 g to fall freely from rest through a vertical distance, as illustrated in Figure 8, and strike the enclosure with the specified impact in a direction perpendicular to the enclosure surface.

**Table 6 – Impact test on the enclosure of apparatus**

Enclosure part	Impact (Joules ± 1%)
Top, sides, back, and front of PORTABLE APPARATUS or table-top apparatus.	2 J
All exposed surfaces of fixed mounted apparatus.	2 J
Top, sides, back, and front of floor-standing apparatus.	3,5 J
<p>NOTE 1 To apply the required impact energy, the correct height is calculated by <math>h = E/(g \times m)</math> where</p> <p><math>h</math> is the vertical distance in metres;</p> <p><math>E</math> is the impact energy in Joules;</p> <p><math>g</math> is the gravitational acceleration of 9,81 m/s<sup>2</sup>;</p> <p><math>m</math> is the mass of the steel ball in kilograms.</p> <p>NOTE 2 For mechanical strength of picture tubes and protection against the effects of implosion, see Clause 18.</p>	

After the test, the apparatus shall withstand the dielectric strength test as specified in 10.4 and shall show no damage in the sense of this standard; in particular:

- HAZARDOUS LIVE parts shall not have become ACCESSIBLE,
- insulating barriers shall not have been damaged, and
- those parts subjected to the impact hammer test shall show no visible cracks.

NOTE Damage to the finish, small dents which do not reduce CLEARANCES or CREEPAGE DISTANCES below the specified values, cracks which are not visible to the naked eye, surface cracks in fibre-reinforced mouldings and the like are ignored.

#### 12.1.5 Drop test

PORTABLE APPARATUS having a mass of 7 kg or less are subjected to a drop test. A sample of the complete apparatus is subjected to three impacts that result from being dropped through a distance of 1 m onto a horizontal surface in positions likely to produce the most adverse results.

The horizontal surface consists of hardwood at least 13 mm thick, mounted on two layers of plywood each 19 mm to 20 mm thick, all supported on a concrete or equivalent non-resilient floor.

For each drop, the test sample shall strike the surface in a different position. When applicable, the sample is to be dropped with the batteries specified by the manufacturer.

After the test, the apparatus need not be operational, but shall show no damage in the sense of this standard and shall withstand the dielectric strength test as specified in 10.4, in particular:

- dangerous moving parts or HAZARDOUS LIVE parts shall not have become ACCESSIBLE; and
- insulating barriers shall not have been damaged; and
- CLEARANCES and CREEPAGE DISTANCES shall not have been reduced below the values specified in Clause 13.

The test criteria shall not be applied through openings in the face of the picture tube.

#### 12.1.6 Stress relief test

Enclosures of moulded or formed thermoplastic materials shall be so constructed that any shrinkage or distortion of the material due to release of internal stresses caused by the moulding or forming operation does not result in the exposure of hazardous parts.

A sample consisting of the complete apparatus, or of the complete enclosure together with any supporting framework, is subjected in a circulating air oven to a temperature 10 K higher than the maximum temperature observed on the enclosure during the test of 7.1.4, but not less than 70 °C, for a period of 7 h, then permitted to cool to room temperature.

For large apparatus where it is impractical to test a complete enclosure, it is permitted to use a portion of the enclosure representative of the complete assembly with regard to thickness and shape, and including any mechanical support members. In such cases, it may be necessary to reassemble the apparatus to determine compliance.

After the test, the apparatus shall show no damage in the sense of this standard, in particular, dangerous moving parts or HAZARDOUS LIVE parts shall not have become ACCESSIBLE.

#### 12.2 Fixing of actuating elements

Actuating elements, for instance knobs, push-buttons, keys and levers, shall be so constructed and fastened that their use will not impair the protection against electric shock.

Compliance is checked by the following tests.

Fixing screws, if any, are loosened and then tightened with 2/3 of the torque given in Table 20 and finally loosened for 1/4 turn.

The actuating elements are then subjected for 1 min to a torque corresponding to a force of 100 N applied at the periphery, but not more than 1 Nm and, for 1 min, to an axial pull of 100 N. If the mass of the apparatus is less than 10 kg, the pulling force is limited to the value corresponding to the mass of the apparatus but not less than 25 N.

For actuating elements such as push-buttons, keys and the like, on which only a pressure is exerted during intended use and which do not protrude more than 15 mm from the surface of the apparatus, the pulling force is limited to 50 N.

After these tests, the apparatus shall show no damage in the sense of this standard.

### **12.3 REMOTE CONTROL devices held in hand**

Parts of REMOTE CONTROL devices intended to be held in hand and containing HAZARDOUS LIVE parts, shall have adequate mechanical strength and be so constructed as to withstand such handling as may be expected.

*Compliance is checked by the following test:*

*The REMOTE CONTROL device, with its flexible cord, if any, shortened to 10 cm, is tested according to 5.3 of IEC 60068-2-31:2008, procedure 2 with a fall height of 500 mm.*

*The barrel is rotated 50 times if the mass of the control device is up to 250 g and 25 times if the mass is greater than 250 g.*

*After the test, the device shall show no damage in the sense of this standard.*

*Parts of cable-connected REMOTE CONTROL devices, not intended to be held in hand, are tested as a part of the attended apparatus.*

### **12.4 Drawers**

Drawers which are intended to be partially pulled out from the apparatus shall have a stop of adequate mechanical strength in order to prevent HAZARDOUS LIVE parts becoming ACCESSIBLE.

*Compliance is checked by the following test:*

*The drawer is pulled out in the intended manner until the stop prevents further movement. A force of 50 N is then applied for 10 s in the most unfavourable direction.*

*After the test, the apparatus shall show no damage in the sense of this standard; in particular no HAZARDOUS LIVE parts shall become ACCESSIBLE.*

### **12.5 Antenna coaxial sockets mounted on the apparatus**

Antenna coaxial sockets mounted on the apparatus and incorporating parts or components which isolate HAZARDOUS LIVE parts from ACCESSIBLE parts shall be constructed so as to withstand such mechanical stresses as may be expected in the intended use.

*Compliance is checked by the following tests, which are made in the order given.*

*After these tests, the apparatus shall show no damage in the sense of this standard.*

#### **Endurance test**

*A test plug as shown in Figure 9 is inserted and withdrawn from the socket 100 times. Care is to be taken not to damage the socket intentionally during insertion and withdrawal of the test plug.*

#### **Impact test**

*A test plug as shown in Figure 9 is inserted into the socket and three successive blows from the spring-operated hammer according to IEC 60068-2-75 are applied with a kinetic energy just before impact of 0,5 J to the same point on the plug in the most unfavourable direction.*

#### **Torque test**

*A test plug as shown in Figure 9 is inserted into the socket and a force of 50 N is applied for 10 s, without jerks, at right angles to the axis of the plug, the radial direction of the force being*

such as to stress those parts of the socket which are likely to be weak. The force is determined by using, for example, a spring balance attached by means of the hole in the test plug.

This test is made 10 times.

NOTE When antenna coaxial sockets different from IEC 60169-2 are tested, a corresponding test plug of the same length is used for the tests.

## 12.6 Telescoping or rod antennas

### 12.6.1 General requirements

A telescoping or rod antenna shall be provided with a minimum 6,0 mm diameter button or ball on the end.

A telescoping or rod antenna shall be provided with a guard or barrier that prevents any part of the antenna or its mounting hardware from falling into the apparatus and contacting HAZARDOUS LIVE parts in the event the antenna or any part of it were to break.

Mounting hardware refers only to parts that are used to mount the antenna or are subject to stress when the antenna is subject to movement.

### 12.6.2 Physical securement

An antenna end piece and the sections of a telescoping antenna shall be secured in such a manner as to prevent removal.

Compliance is checked by the following test:

The end piece shall be subjected to a 20 N force along the major axis of the antenna for a period of 1 min. In addition, if the end piece is attached by screw threads, a loosening torque is to be applied to the end pieces of five additional samples. The torque is to be gradually applied with the rod fixed. When the specific torque is reached, it is to be maintained for no more than 15 s. The holding time for any one sample shall not be less than 5 s and the average holding time of the five samples shall not be less than 8 s.

The value of torque is given in Table 7.

**Table 7 – Torque values for end-piece test**

End-piece diameter mm	Torque Nm
Less than 8,0	0,3
Equal to, or greater than, 8,0	0,6

## 12.7 Apparatus containing COIN / BUTTON CELL BATTERIES

### 12.7.1 General

These requirements apply to apparatus, including remote controls, that:

- are likely to be ACCESSIBLE to children, taking into account information given by the manufacturer; and
- include lithium COIN/BUTTON CELL BATTERIES with a diameter of 32 mm or less.

These requirements do not apply to:

- PROFESSIONAL APPARATUS;

NOTE PROFESSIONAL APPARATUS is an apparatus sold through special sales channels. All apparatus sold through normal electronics stores are considered not to be professional apparatus.

- apparatus for locations where it is unlikely that children will be present; or
- apparatus containing COIN/BUTTON CELL BATTERIES that are soldered in place.

### **12.7.2 Construction requirements**

Apparatus having a battery compartment door / cover shall be designed to reduce the possibility of children removing the battery by one of the following methods:

- a tool, such as a screwdriver or coin, is required to open the battery compartment; or
- the battery compartment door/cover requires the application of a minimum of two independent and simultaneous movements to open BY HAND.

### **12.7.3 Tests**

#### **12.7.3.1 Test sequence**

*One sample shall be subjected to the applicable tests of 12.7.3.2 to 12.7.3.6. If applicable, the test in 12.7.3.2 shall be conducted first.*

#### **12.7.3.2 Stress relief test**

*If the battery compartment utilizes moulded or formed thermoplastic materials, the sample consisting of the complete sample, or of the complete enclosure together with any supporting framework, is tested according to the stress relief test of 12.1.6. During the test, the battery may be removed so as not to expose it to excessive temperature.*

#### **12.7.3.3 Battery replacement test**

*For equipment with a battery compartment door / cover, the battery compartment shall be opened and closed and the battery removed and replaced ten times to simulate normal replacement according to the manufacturer's instructions.*

*If the battery compartment door/cover is secured by one or more screws, the screws are loosened and then tightened applying a continuous linear torque according to Table 20, using a suitable screwdriver, spanner or key. The screws are to be completely removed and reinserted each time.*

#### **12.7.3.4 Drop test**

*PORTABLE APPARATUS having a mass of 7 kg or less are subjected to three drops from a height of 1 m onto a horizontal surface in positions likely to produce the maximum force on the battery compartment in accordance with 12.1.5.*

*If the equipment is a remote control, it shall be subjected to ten drops.*

#### **12.7.3.5 Impact test**

*The battery compartment door / cover shall be subjected to three impacts in a direction perpendicular to the battery compartment door / cover according to 12.1.4 with a force of:*

- 0,5 J (102 mm  $\pm$  10 mm height) for glasses for watching, for example, 3 dimensional television; or
- 2 J (408 mm  $\pm$  10 mm height) for all other doors / covers.

#### **12.7.3.6 Crush test**

*Hand held remote control devices are to be supported by a fixed rigid supporting surface in a*

position likely to produce the most adverse results as long as the position can be self-supported. A crushing force of  $330\text{ N} \pm 5\text{ N}$  is applied to the exposed top and back surfaces of remote control devices placed in a stable condition by a flat surface measuring approximately 102 mm by 250 mm for a period of 10 s.

#### 12.7.4 Compliance

Compliance is checked by applying a force of  $30\text{ N} \pm 1\text{ N}$  for 10 s to the battery compartment door / cover by a rigid test finger according to the test probe 11 of IEC 61032:1997 at the most unfavourable place and in the most unfavourable direction. The force shall be applied in one direction at a time.

The battery compartment door/cover shall remain functional, and:

- the COIN/BUTTON CELL BATTERY shall not become ACCESSIBLE; or
- it shall not be possible remove the battery from the product with the test hook of Figure 4 using a force of 20 N.

### 13 CLEARANCES and CREEPAGE DISTANCES

#### 13.1 General

CLEARANCES shall be so dimensioned that overvoltage transients which may enter the apparatus, and peak voltages which may be generated within the apparatus, do not break down the CLEARANCE. Detailed requirements are given in 13.3.

CREEPAGE DISTANCES shall be so dimensioned that, for a given WORKING VOLTAGE and pollution degree, no flashover or breakdown (tracking) of insulation will occur. Detailed requirements are given in 13.4.

NOTE In order to determine the CLEARANCE, the peak value of the WORKING VOLTAGE is measured. For the determination of the CREEPAGE DISTANCE, the r.m.s. or d.c. value of the WORKING VOLTAGE is measured.

The methods of measuring CLEARANCES and CREEPAGE DISTANCES are given in Annex E.

It is permitted for CLEARANCES and CREEPAGE DISTANCES to be divided by intervening, unconnected (floating) conductive parts, such as unused contacts of a connector, provided that the sum of the individual distances meets the specified minimum requirements (see Figure E.8).

The various pollution degrees for the minimum CLEARANCE and CREEPAGE DISTANCE values given, apply as follows:

- pollution degree 1 for components and assemblies which are sealed so as to exclude dust and moisture;
- pollution degree 2 generally for apparatus covered by the scope of this standard; or
- pollution degree 3 where a local internal environment within the apparatus is subject to conductive pollution or to dry non-conductive pollution which could become conductive due to expected condensation, or the apparatus is located in an area where the external environment is such that conductive pollution or dry non-conductive pollution which could become conductive, is present.

Except for insulation between parts of different polarity DIRECTLY CONNECTED TO THE MAINS, CLEARANCES and CREEPAGE DISTANCES smaller than those specified are allowed but are subject to the requirements of 4.3.2, 4.3.3 and 11.2.

### **13.2 Determination of WORKING VOLTAGE**

*In determining the WORKING VOLTAGE, all of the following requirements apply:*

- *no voltage variation (0,9 or 1,1) shall be applied to the RATED SUPPLY VOLTAGE of the apparatus;*
- *the WORKING VOLTAGE between any point in a circuit CONDUCTIVELY CONNECTED TO THE MAINS and earth, and between any point in a circuit CONDUCTIVELY CONNECTED TO THE MAINS and a circuit not CONDUCTIVELY CONNECTED TO THE MAINS, shall be assumed to be the greatest of the following:*
  - *the RATED SUPPLY VOLTAGE or the highest measured voltage between such points during operation at the RATED SUPPLY VOLTAGE, or*
  - *the upper voltage of the RATED SUPPLY VOLTAGE range or the highest measured voltage between such points during operation at any value within the RATED SUPPLY VOLTAGE range;*
- *unearthed ACCESSIBLE conductive parts shall be assumed to be earthed;*
- *where a wire-wound component or other part is floating, i.e. not connected to a circuit which establishes its potential relative to earth, it shall be assumed to be earthed at the point by which the highest WORKING VOLTAGE is obtained;*
- *where DOUBLE INSULATION is used, the WORKING VOLTAGE across the BASIC INSULATION shall be determined by imagining a short circuit across the SUPPLEMENTARY INSULATION, and vice-versa. For DOUBLE INSULATION between windings of a wire-wound component, the short circuit shall be assumed to take place at the point by which the highest WORKING VOLTAGE is produced in the other insulation;*
- *except as permitted below, for insulation between two windings of a wire-wound component, the highest voltage between any two points in the two windings shall be used, taking into account external voltages to which the windings will be connected;*
- *except as permitted below, for insulation between a winding of a wire-wound component and another part, the highest voltage between any point on the winding and the other part shall be used.*

*If the insulation of a wire-wound component has different WORKING VOLTAGES along the length of the winding, it is permitted to vary CLEARANCES, CREEPAGE DISTANCES and distances through insulation accordingly.*

NOTE An example of such a construction is a 30 kV winding, consisting of multiple bobbins connected in series, and earthed at one end.

### **13.3 CLEARANCES**

#### **13.3.1 General**

It is permitted to use either the following method or the alternative method in Annex J for a particular component or subassembly or for the whole apparatus.

NOTE 1 The advantages of Annex J are as follows:

- CLEARANCES are aligned with the basic safety publication IEC 60664-1, and are therefore harmonised with other safety publications (for example for transformers);
- attenuation of transients within the apparatus is considered, including attenuation of transients in circuits CONDUCTIVELY CONNECTED TO THE MAINS.

NOTE 2 CLEARANCE requirements are based on the expected overvoltage transients which can enter the apparatus from the a.c. MAINS. According to IEC 60664-1, the magnitude of these transients is determined by the nominal MAINS voltage and the supply arrangements. These transients are categorised according to IEC 60664-1 into four groups as overvoltage categories I to IV (also known as installation categories I to IV).

NOTE 3 The design of solid insulation and CLEARANCES can be co-ordinated in such a way that if an incident overvoltage transient exceeds the limits of overvoltage category II, the solid insulation can withstand a higher voltage than the CLEARANCES.

For all a.c. power systems, the a.c. MAINS voltage in Table 8, Table 9 and Table 10 is the line-to-neutral voltage.

NOTE 4 In Norway, due to the IT power distribution system used, the a.c. MAINS voltage is considered to be equal to the line-to-line voltage, and will remain 230 V in case of a single earth fault.

The specified CLEARANCES are not applicable to the air gap between the contacts of thermostats, THERMAL CUT-OUTS, overload protection devices, switches of microgap construction, and similar components where the CLEARANCE varies with the contacts.

NOTE 5 For air gaps between contacts of disconnect switches, see 8.18.

*Compliance with 13.3 is checked by measurement, taking into account Annex E. The following conditions are applicable. There is no dielectric strength test to verify CLEARANCES.*

*Movable parts shall be placed in the most unfavourable position.*

*Unless adequate insulation is maintained in all possible positions of the coil, CLEARANCES between a loudspeaker voice coil and adjacent conductive parts are considered to be conductively connected.*

*When measuring CLEARANCES from an enclosure of insulating material through a slot or opening in the enclosure, the ACCESSIBLE surface shall be considered to be conductive as if it were covered by metal foil wherever it can be touched by the test finger, according to test probe B of IEC 61032:1997 (see 9.1.1.3), applied without appreciable force (see Figure 3, point B).*

*Forces shall be applied to any point on internal parts and then to the outside of conductive enclosures, in an endeavour to reduce the CLEARANCE while taking measurements. The forces shall have a value of*

- 2 N for internal parts; and
- 30 N for enclosures.

*The force shall be applied to the enclosure by means of the rigid test finger according to IEC 61032:1997, test probe 11.*

### **13.3.2 CLEARANCES in circuits CONDUCTIVELY CONNECTED TO THE MAINS**

CLEARANCES in circuits CONDUCTIVELY CONNECTED TO THE MAINS shall comply with the minimum dimensions in Table 8 and, where appropriate, Table 9.

Table 8 is applicable to apparatus that will not be subjected to transients exceeding overvoltage category II according to IEC 60664-1. The appropriate MAINS transient voltages are given in parentheses in each nominal a.c. MAINS voltage column. If higher transients are expected, additional protection might be necessary in the supply to the apparatus or in the installation.

NOTE 1 Annex J provides an alternative design method.

For circuits CONDUCTIVELY CONNECTED TO THE MAINS operating on nominal a.c. MAINS voltages up to 300 V, if the peak WORKING VOLTAGE in the circuit exceeds the peak value of the nominal a.c. MAINS voltage, the minimum CLEARANCE for the insulation under consideration is the sum of the following two values:

- the minimum CLEARANCE value from Table 8 for an WORKING VOLTAGE equal to the nominal a.c. MAINS voltage; and

NOTE 2 For the purpose of the use of Table 8, it is assumed that the WORKING VOLTAGE is equal to the nominal a.c. MAINS voltage.

- the appropriate additional CLEARANCE value from Table 9.

For an WORKING VOLTAGE to be used in determining CLEARANCES for circuits CONDUCTIVELY CONNECTED TO THE MAINS in accordance with Table 8:

- the peak value of any superimposed ripple on a d.c. voltage which exceeds that permitted in 2.3.3, shall be included;
- non-repetitive transients (due, for example, to atmospheric disturbances) shall not be taken into account;

NOTE 3 It is assumed that any such non-repetitive transients in a circuit not CONDUCTIVELY CONNECTED TO THE MAINS will not exceed the MAINS transient voltage of the circuit CONDUCTIVELY CONNECTED TO THE MAINS.

- the voltage of any circuit not HAZARDOUS LIVE or TNV CIRCUIT (including ringing voltage) shall be regarded as zero;

and in accordance with Table 9, where appropriate, for peak WORKING VOLTAGES exceeding the values of the nominal a.c. MAINS voltage, the maximum peak WORKING VOLTAGE shall be used.

NOTE 4 Use of CLEARANCE – Tables 8 and 9:

Select the appropriate column in Table 8 for the nominal a.c. MAINS voltage and pollution degree. Select the row appropriate to an WORKING VOLTAGE equal to the a.c. MAINS voltage. Note the minimum CLEARANCE requirement.

Go to Table 9. Select the appropriate column for the nominal a.c. MAINS voltage and pollution degree and choose the row in that column which covers the actual peak WORKING VOLTAGE. Read the additional CLEARANCE required from one of the two right-hand columns and add this to the minimum CLEARANCE from Table 8 to give the total minimum CLEARANCE.

FOR BIS INTERNAL USE. TO BE  
USED FOR STANDARDS  
DEVELOPMENT PURPOSE ONLY

**Table 8 – Minimum CLEARANCES for insulation in circuits CONDUCTIVELY CONNECTED TO THE MAINS and between such circuits and circuits not CONDUCTIVELY CONNECTED TO THE MAINS**

*CLEARANCES in millimetres*

WORKING VOLTAGE up to and including		Nominal a.c. MAINS voltage $\leq 150$ V (MAINS transient voltage 1 500 V)				Nominal a.c. MAINS voltage $> 150$ V $\leq 300$ V (MAINS transient voltage 2 500 V)		Nominal a.c. MAINS voltage $> 300$ V $\leq 600$ V (MAINS transient voltage 4 000 V)	
Voltage peak or d.c. V	Voltage r.m.s. (sinu-soidal) V	Pollution degrees 1 and 2		Pollution degree 3		Pollution degrees 1, 2 and 3		Pollution degrees 1, 2 and 3	
		B/S	R	B/S	R	B/S	R	B/S	R
210	150	1,0 (0,5)	2,0 (1,0)	1,3 (0,8)	2,6 (1,6)	2,0 (1,5)	4,0 (3,0)	3,2 (3,0)	6,4 (6,0)
420	300	B/S 2,0 (1,5) R 4,0 (3,0)						3,2 (3,0)	6,4 (6,0)
840	600	B/S 3,2 (3,0) R 6,4 (6,0)							
1 400	1 000	B/S 4,2 R 6,4							
2 800	2 000	B/S/R 8,4							
7 000	5 000	B/S/R 17,5							
9 800	7 000	B/S/R 25							
14 000	10 000	B/S/R 37							
28 000	20 000	B/S/R 80							
42 000	30 000	B/S/R 130							

The values in the table are applicable to BASIC INSULATION (B), SUPPLEMENTARY INSULATION (S) and REINFORCED INSULATION (R)

The values in parentheses are applicable to BASIC INSULATION, SUPPLEMENTARY INSULATION or REINFORCED INSULATION only if manufacturing is subjected to a quality control programme (an example for such a programme is given in Annex M). In particular, DOUBLE INSULATION and REINFORCED INSULATION shall be subjected to ROUTINE TESTS for dielectric strength.

For WORKING VOLTAGES between 420 V (peak) or d.c. and 42 000 V (peak) or d.c., linear interpolation between the nearest two points and for values exceeding 42 000 (peak) or d.c. extrapolation is permitted, the calculated spacing being rounded up to the next higher 0,1 mm increment.

For an explanation of the pollution degrees, see 13.1.

**Table 9 – Additional CLEARANCES for insulation in circuits CONDUCTIVELY CONNECTED TO THE MAINS with peak WORKING VOLTAGES exceeding the peak value of the nominal a.c. MAINS voltage and between such circuits and circuits not CONDUCTIVELY CONNECTED TO THE MAINS**

Nominal a.c. MAINS voltage ≤ 150 V		Nominal a.c. MAINS voltage > 150 V ≤ 300 V	Additional CLEARANCE mm	
Pollution degrees 1 and 2	Pollution degree 3	Pollution degrees 1, 2 and 3	BASIC OR SUPPLEMENTARY INSULATION	REINFORCED INSULATION
Maximum WORKING VOLTAGE V (peak)	Maximum WORKING VOLTAGE V (peak)	Maximum WORKING VOLTAGE V (peak)		
210 (210)	210 (210)	420 (420)	0	0
298 (288)	294 (293)	493 (497)	0,1	0,2
386 (366)	379 (376)	567 (575)	0,2	0,4
474 (444)	463 (459)	640 (652)	0,3	0,6
562 (522)	547 (541)	713 (729)	0,4	0,8
650 (600)	632 (624)	787 (807)	0,5	1,0
738 (678)	715 (707)	860 (884)	0,6	1,2
826 (756)	800 (790)	933 (961)	0,7	1,4
914 (839)		1 006 (1 039)	0,8	1,6
1 002 (912)		1 080 (1 116)	0,9	1,8
1 090 (990)		1 153 (1 193)	1,0	2,0
		1 226 (1 271)	1,1	2,2
		1 300 (1 348)	1,2	2,4
		– (1 425)	1,3	2,6

The values in parentheses shall be used when the values in parentheses in Table 8 are used in accordance with note 2 of Table 8.

For WORKING VOLTAGES above those shown in the table, linear extrapolation is allowed.

Linear interpolation between the nearest two points is permitted, the calculated spacing being rounded up to the next higher 0,1 mm increment.

For an explanation of the pollution degrees, see 13.1.

### 13.3.3 CLEARANCES in circuits not CONDUCTIVELY CONNECTED TO THE MAINS

CLEARANCES in circuits not CONDUCTIVELY CONNECTED TO THE MAINS shall comply with the minimum dimensions of Table 10.

For an WORKING VOLTAGE to be used in determining CLEARANCES for circuits not CONDUCTIVELY CONNECTED TO THE MAINS in accordance with Table 10:

- the peak value of any superimposed ripple on a d.c. voltage which exceeds that permitted in 2.3.3, shall be included; and
- the peak value shall be used for non-sinusoidal voltages.

Circuits not CONDUCTIVELY CONNECTED TO THE MAINS will normally be overvoltage category I if the MAINS is overvoltage category II; the maximum transients in overvoltage category I for various a.c. MAINS voltages are shown in the column headings of Table 10. However, a floating circuit not CONDUCTIVELY CONNECTED TO THE MAINS in an apparatus that has anywhere a connector (for example antenna, signal input) that could be earthed, shall be subjected to the requirements for circuits CONDUCTIVELY CONNECTED TO THE MAINS in Tables 8 and 9 unless it is in apparatus with a PROTECTIVE EARTHING TERMINAL and either

- the floating circuit is separated from the circuit CONDUCTIVELY CONNECTED TO THE MAINS by an earthed metal screen; or
- transients on the circuit not CONDUCTIVELY CONNECTED TO THE MAINS are below the permitted maximum value for overvoltage category I (for example due to being attenuated by connecting a component, such as a capacitor, between the circuit not CONDUCTIVELY CONNECTED TO THE MAINS and earth). See 13.3.4 for the method of measuring the transient level.

If the TELECOMMUNICATION NETWORK TRANSIENT VOLTAGE is known, the known value should be used.

If the TELECOMMUNICATION NETWORK TRANSIENT VOLTAGE is not known, an assumed transient rating of 800 V (peak) should be used for TNV-2 CIRCUITS and 1,5 kV (peak) for TNV-1 CIRCUITS and TNV-3 CIRCUITS.

If it is known that the incoming transients are attenuated within the apparatus, the value to be used should be determined in accordance with 13.3.4 b).

FOR BIS INTERNAL USE. TO BE  
USED FOR STANDARDS  
DEVELOPMENT PURPOSE ONLY

Table 10 – Minimum CLEARANCES in circuits not CONDUCTIVELY CONNECTED TO THE MAINS

CLEARANCES in millimetres

WORKING VOLTAGE up to and including		Nominal a.c. MAINS voltage ≤ 150 V (transient rating for circuits not CONDUCTIVELY CONNECTED TO THE MAINS 800 V) <sup>b</sup>				Nominal a.c. MAINS voltage > 150 V ≤ 300 V (transient rating for circuits not CONDUCTIVELY CONNECTED TO THE MAINS 1 500 V) <sup>b</sup>				Nominal a.c. MAINS voltage > 300 V ≤ 600 V (transient rating for circuits not CONDUCTIVELY CONNECTED TO THE MAINS 2 500 V) <sup>b</sup>		Circuits not subject to transient overvoltages <sup>a</sup>	
Voltage peak or d.c. V	Voltage r.m.s. sinusoidal V	Pollution degrees 1 and 2		Pollution degree 3		Pollution degrees 1 and 2		Pollution degree 3		Pollution degrees 1, 2 and 3		Pollution degrees 1 and 2 only	
		B/S	R	B/S	R	B/S	R	B/S	R	B/S	R	B/S	R
71	50	0,7 (0,2)	1,4 (0,4)	1,3 (0,8)	2,6 (1,6)	1,0 (0,5)	2,0 (1,0)	1,3 (0,8)	2,6 (1,6)	2,0 (1,5)	4,0 (3,0)	0,4 (0,2)	0,8 (0,4)
140	100	0,7 (0,2)	1,4 (0,4)	1,3 (0,8)	2,6 (1,6)	1,0 (0,5)	2,0 (1,0)	1,3 (0,8)	2,6 (1,6)	2,0 (1,5)	4,0 (3,0)	0,7 (0,2)	1,4 (0,4)
210	150	0,9 (0,2)	1,8 (0,4)	1,3 (0,8)	2,6 (1,6)	1,0 (0,5)	2,0 (1,0)	1,3 (0,8)	2,6 (1,6)	2,0 (1,5)	4,0 (3,0)	0,7 (0,2)	1,4 (0,4)
280	200	B/S 1,4 (0,8) R 2,8 (1,6)								2,0 (1,5)	4,0 (3,0)	1,1 (0,2)	2,2 (0,4)
420	300	B/S 1,9 (1,0) R 3,8 (2,0)								2,0 (1,5)	4,0 (3,0)	1,4 (0,2)	2,8 (0,4)
700	500							B/S 2,5		R 5,0			
840	600							B/S 3,2		R 5,0			
1 400	1 000							B/S 4,2		R 5,0			
2 800	2 000							B/S/R 8,4		c			
7 000	5 000							B/S/R 17,5		c			
9 800	7 000							B/S/R 25		c			
14 000	10 000							B/S/R 37		c			
28 000	20 000							B/S/R 80		c			
42 000	30 000							B/S/R 130		c			
<p>The values in the table are applicable to BASIC INSULATION (B), SUPPLEMENTARY INSULATION (S) and REINFORCED INSULATION (R).</p> <p>The values in parentheses are applicable to BASIC INSULATION, SUPPLEMENTARY INSULATION or REINFORCED INSULATION only if manufacturing is subjected to a quality control programme (an example for such a programme is given in Annex M). In particular, DOUBLE and REINFORCED INSULATION shall be subjected to ROUTINE TESTS for dielectric strength.</p> <p>For WORKING VOLTAGES between 420 V (peak) or d.c. and 42 000 V (peak) or d.c., linear interpolation is permitted between the nearest two points, the calculated spacing being rounded up to the next higher 0,1 mm increment. For WORKING VOLTAGES exceeding 42 000 V (peak) or d.c., linear extrapolation is permitted, the calculated spacing being rounded up to the next higher 0,1 mm increment.</p> <p>For explanation of the pollution degrees, see 13.1.</p> <p>For lower transient voltages, Table F.2 of IEC 60664-1:2007 may be used.</p>													
<p>a The values are applicable to d.c. circuits not CONDUCTIVELY CONNECTED TO THE MAINS which are reliably connected to earth and have capacitive filtering which limits the peak-to-peak ripple to 10 % of the d.c. voltage.</p> <p>b Where transients in the apparatus exceed this value, the appropriate higher CLEARANCE shall be used.</p> <p>c For WORKING VOLTAGES above 1 400 V peak or 1 000 V r.m.s., the minimum CLEARANCE is 5 mm provided that the CLEARANCE path passes an electric strength test according to 10.4.2 using:</p> <ul style="list-style-type: none"> <li>– an a.c. test voltage whose r.m.s. value is 106 % of the peak WORKING VOLTAGE; or</li> <li>– a d.c. test voltage equal to 150 % of the peak WORKING VOLTAGE.</li> </ul> <p>If the CLEARANCE path is partly along the surface of a material that is not material group I, the dielectric strength test is conducted across the air gap only.</p>													

### 13.3.4 Measurement of transient voltages

The following tests are conducted only where it is required to determine whether or not transient voltages across the CLEARANCE in any circuit are lower than normal, due, for example, to the effect of a filter in the apparatus. The transient voltage across the CLEARANCE is measured using the following test procedure, and the CLEARANCE shall be based on the measured value.

During the tests, the apparatus is connected to its separate SUPPLY APPARATUS, if any, but is not connected to the MAINS, nor to any network, for example TELECOMMUNICATION NETWORKS, and any surge suppressors in circuits CONDUCTIVELY CONNECTED TO THE MAINS are disconnected.

A voltage measuring device is connected across the CLEARANCE in question.

#### a) Transients due to MAINS overvoltages

To measure the reduced level of transients due to MAINS overvoltages, the impulse test generator of Annex K is used to generate 1,2/50  $\mu$ s impulses, with  $U_c$  equal to the MAINS transient voltage given in the column headings of Table 8.

Three to six impulses of alternating polarity, with intervals of at least 1 s between impulses, are applied between each of the following points where relevant:

- line-to-line;
- all line conductors joined together and neutral;
- all line conductors joined together and protective earth; and
- neutral and protective earth.

#### b) Transients due to TELECOMMUNICATION NETWORK overvoltages

To measure the reduced level of transients due to TELECOMMUNICATION NETWORK overvoltages, the impulse test generator of Annex K is used to generate 10/700  $\mu$ s impulses, with  $U_c$  equal to the TELECOMMUNICATION NETWORK TRANSIENT VOLTAGE.

If the TELECOMMUNICATION NETWORK TRANSIENT VOLTAGE is not known for the TELECOMMUNICATION NETWORK in question, it shall be taken as

- 1 500  $V_{peak}$  if the circuit connected to the TELECOMMUNICATION NETWORK is a TNV-1 CIRCUIT or a TNV-3 CIRCUIT; and
- 800  $V_{peak}$  if the circuit connected to the TELECOMMUNICATION NETWORK is a TNV-0 CIRCUIT or a TNV-2 CIRCUIT.

Three to six impulses of alternating polarity, with intervals of at least 1 s between impulses, are applied between each of the following TELECOMMUNICATION NETWORK connection points:

- each pair of TERMINALS (for example, A and B or tip and ring) in an interface;
- all TERMINALS of a single interface type joined together and earth.

### 13.4 CREEPAGE DISTANCES

CREEPAGE DISTANCES shall be not less than the appropriate minimum values specified in Table 11, taking into account the value of the WORKING VOLTAGE, the pollution degree and the material group.

If the CREEPAGE DISTANCE derived from Table 11 is less than the applicable CLEARANCE as determined in 13.3 or Annex J, then the value for that CLEARANCE shall be applied for the minimum CREEPAGE DISTANCE.

It is permitted to use minimum CREEPAGE DISTANCES equal to the applicable CLEARANCES for glass, mica, ceramic or similar materials.

For the WORKING VOLTAGE to be used in determining CREEPAGE DISTANCES:

- the actual r.m.s. or d.c. value shall be used;  
If the r.m.s. value is measured, care shall be taken that measuring instruments give true r.m.s. readings of non-sinusoidal waveforms as well as sinusoidal waveforms.
- if the d.c. value is used, any superimposed ripple shall not be taken into account;
- short-term conditions (for example, cadenced ringing signals in TNV CIRCUITS) shall not be taken into account; and
- short-term disturbances (for example transients) shall not be taken into account.

When determining the WORKING VOLTAGE for a TNV CIRCUIT connected to a TELECOMMUNICATION NETWORK whose characteristics are not known, the normal WORKING VOLTAGES shall be assumed to be the following values:

- 60 V d.c. for TNV-1 CIRCUITS;
- 120 V d.c. for TNV-2 CIRCUITS and TNV-3 CIRCUITS.

Material groups are classified as follows:

Material group I	$600 \leq \text{CTI}$ (comparative tracking index)
Material group II	$400 \leq \text{CTI} < 600$
Material group IIIa	$175 \leq \text{CTI} < 400$
Material group IIIb	$100 \leq \text{CTI} < 175$

The material group is verified by evaluation of the test data for the material according to IEC 60112 using 50 drops of solution A.

If the material group is not known, material group IIIb shall be assumed. If a CTI of 175 or greater is needed, and the data is not available, the material group can be established with a test for proof tracking index (PTI) as detailed in IEC 60112. A material may be included in a group if its PTI established by these tests is equal to, or greater than, the lower value of the CTI specified for the group.

Table 11 – Minimum CREEPAGE DISTANCES

*CREEPAGE DISTANCES in millimetres*

WORKING VOLTAGE up to and including	BASIC and SUPPLEMENTARY INSULATION						
	Pollution degree 1	Pollution degree 2			Pollution degree 3		
	Material group	Material group			Material group		
V r.m.s. or d.c.	I, II, IIIa or IIIb	I	II	IIIa or IIIb	I	II	IIIa or IIIb
10	a	0,4	0,4	0,4	1,0	1,0	1,0
12,5		0,42	0,42	0,42	1,05	1,05	1,05
16		0,45	0,45	0,45	1,1	1,1	1,1
20		0,48	0,48	0,48	1,2	1,2	1,2
25		0,5	0,5	0,5	1,25	1,25	1,25
32		0,53	0,53	0,53	1,3	1,3	1,3
40		0,56	0,8	1,1	1,4	1,6	1,8
50		0,6	0,85	1,2	1,5	1,7	1,9
63		0,63	0,9	1,25	1,6	1,8	2,0
80		0,67	0,9	1,3	1,7	1,9	2,1
100		0,71	1,0	1,4	1,8	2,0	2,2
125		0,75	1,05	1,5	1,9	2,1	2,4
160		0,8	1,1	1,6	2,0	2,2	2,5
200		1,0	1,4	2,0	2,5	2,8	3,2
250		1,25	1,8	2,5	3,2	3,6	4,0
320		1,6	2,2	3,2	4,0	4,5	5,0
400		2,0	2,8	4,0	5,0	5,6	6,3
500		2,5	3,6	5,0	6,3	7,1	8,0
630		3,2	4,5	6,3	8,0	9,0	10
800		4,0	5,6	8,0	10	11	12,5
1 000		5,0	7,1	10	12,5	14	16
1 250		6,3	9,0	12,5	16	18	20
1 600		8,0	11	16	20	22	25
2 000		10	14	20	25	28	32
2 500		12,5	18	25	32	36	40
3 200		16	22	32	40	45	50
4 000		20	28	40	50	56	63
5 000		25	36	50	63	71	80
6 300	32	45	63	80	90	100	
8 000	40	56	80	100	110	125	
10 000	50	71	100	125	140	160	
12 500	63	90	125				
16 000	80	110	160				
20 000	100	140	200				
25 000	125	180	250				
32 000	160	220	320				
40 000	200	280	400				
50 000	250	360	500				
63 000	320	450	600				

Linear interpolation is permitted between the nearest two points, the calculated spacing being rounded to the next higher 0,1 mm increment.

For REINFORCED INSULATION, the values for CREEPAGE DISTANCE are twice the values for BASIC INSULATION in this table. In case of interpolation, rounding is done after the doubling.

For explanation of the pollution degrees, see 13.1.

<sup>a</sup> No minimum CREEPAGE DISTANCES are specified for insulation in pollution degree 1. The minimum CLEARANCES apply, as determined in 13.3 or Annex J.

*Compliance is checked by measurement, taking into account Annex E.*

*The following conditions are applicable.*

*Movable parts are placed in their most unfavourable positions.*

*For apparatus incorporating ordinary non-detachable power supply cords, CREEPAGE DISTANCE measurements are made with supply conductors of the largest cross-sectional area specified in 15.3.5, and also without conductors.*

*When measuring CREEPAGE DISTANCES from an enclosure of insulating material through a slot or opening in the enclosure, the ACCESSIBLE surface is considered to be conductive as if it were covered by metal foil wherever it can be touched by the test finger, according to test probe B of IEC 61032:1997 (see 9.1.1.3), applied without appreciable force (see Figure 3, point B).*

NOTE The presence of adhesive on insulation tapes might have an influence on the CTI.

### **13.5 PRINTED BOARDS**

**13.5.1** The minimum CLEARANCES and CREEPAGE DISTANCES between conductors, one of which may be CONDUCTIVELY CONNECTED TO THE MAINS, on PRINTED BOARDS complying with the pull-off and peel strength requirements of the relevant part of IEC 60249-2 are given in Figure 10, and for which the following applies:

- these distances only apply as far as overheating is concerned (see 11.2) to the conductors themselves, not to mounted components or associated solder connections; and
- coatings of lacquer or the like, except coatings according to IEC 60664-3, are ignored when measuring the distances.

**13.5.2** For type B coated PRINTED BOARDS, insulation between conductors shall comply with the requirements of IEC 60664-3. This applies only to BASIC INSULATION.

NOTE 1 For such PRINTED BOARDS, CLEARANCES and CREEPAGE DISTANCES under the coating do not exist.

NOTE 2 For multilayer printed board constructions, see 2.10.6.4 and Table 2R of IEC 60950-1:2005.

### **13.6 Jointed insulation**

Distances between conductive parts along uncemented joints shall be considered as CLEARANCES and CREEPAGE DISTANCES for which the values of 13.3 or Annex J and 13.4 apply.

For reliably cemented joints, complying with the following tests, CLEARANCES and CREEPAGE DISTANCES do not exist. In this case only 8.8 applies.

*Compliance is checked by inspection, measurement and test.*

*For this test, enamelled winding wires, if any, are replaced by uninsulated wires.*

*The materials are considered to be cemented together, if they withstand the following test.*

*Three apparatus, components or subassemblies are subjected 10 times to the following temperature cycle:*

- 68 h at  $(X \pm 2)$  °C,
- 1 h at  $(25 \pm 2)$  °C,
- 2 h at  $(0 \pm 2)$  °C,
- 1 h at  $(25 \pm 2)$  °C,

whereby  $X$  is the highest temperature measured under normal operating conditions on the apparatus, component or subassembly under consideration plus 10 K with a minimum of 85 °C.

One apparatus, component or subassembly is subjected to the relevant dielectric strength test of 10.4, without the humidity treatment of 10.3, however, the test voltage is multiplied by 1,6.

This test is performed immediately after the 68 h temperature conditioning of the last cycle.

Upon conclusion of the complete number of cycles, the two remaining apparatus, components or subassemblies are subjected to the relevant dielectric strength test of 10.4; however, the test voltages are multiplied by 1,6.

NOTE The test voltage is higher than the normal test voltage in order to ensure that, if the surfaces are not cemented together, a breakdown occurs.

For transformers, magnetic couplers and similar devices, if insulation is relied upon for safety, a voltage of 500 V r.m.s. at a frequency of 50 Hz or 60 Hz is applied between windings, and also between windings and other conductive parts, during the thermal cycling condition above.

No evidence of insulation breakdown shall occur during this test.

### 13.7 Enclosed and sealed parts

For apparatus, subassemblies or components, not CONDUCTIVELY CONNECTED TO THE MAINS and which are enclosed, enveloped or hermetically sealed against ingress of dirt and moisture, the minimum internal CLEARANCES and CREEPAGE DISTANCES may be reduced to the values as given in Table 12.

NOTE Examples of such constructions include hermetically sealed metal boxes, adhesive sealed plastic boxes, parts enveloped in a dip coat or by type A coatings according to IEC 60664-3 of PRINTED BOARDS.

**Table 12 – Minimum CLEARANCES and CREEPAGE DISTANCES  
(enclosed, enveloped or hermetically sealed constructions)**

WORKING VOLTAGE up to and including V (peak) a.c. or V d.c.	Minimum CLEARANCES and CREEPAGE DISTANCES
	mm
35	0,2
45	0,2
56	0,3
70	0,3
90	0,4
110	0,4
140	0,5
180	0,7
225	0,8
280	1,0
360	1,1
450	1,3
560	1,6
700	1,9
900	2,3
1 120	2,6
1 400	3,2
1 800	4,2
2 250	5,6
2 800	7,5
3 600	10,0
4 500	12,5
5 600	16,0
7 000	20,0
9 000	25,0
11 200	32,0
14 000	40,0

The values are applicable to both BASIC INSULATION and SUPPLEMENTARY INSULATION.  
The values for REINFORCED INSULATION shall be twice the values in the table.  
A minimum CTI (comparative tracking index) of 100 is required for the insulating materials used. The CTI rating refers to the value obtained in accordance with IEC 60112, solution A.  
Linear interpolation between the nearest two points is allowed, the calculated spacing being rounded to the next higher 0,1 mm increment.

*Compliance is checked by inspection, measurement and by subjecting the apparatus, subassembly or component 10 times to the following temperature cycle:*

- 68 h at  $(Y \pm 2)$  °C,
- 1 h at  $(25 \pm 2)$  °C,
- 2 h at  $(0 \pm 2)$  °C,
- 1 h at  $(25 \pm 2)$  °C,

*whereby Y is the highest temperature measured under normal operating conditions of the apparatus, subassembly or component under consideration, with a minimum of 85 °C. In case of transformers, Y is the highest winding temperature measured under normal operating conditions, plus 10 K, with a minimum of 85 °C.*

*The apparatus, subassembly or component is then subjected to the dielectric strength test of 10.4.*

*The tests are carried out on three samples.*

*No failure is allowed.*

**13.8** The distances between conductive parts internal to apparatus, subassemblies or components which are treated with insulating compound filling all voids, so that CLEARANCES and CREEPAGE DISTANCES do not exist, shall be subject only to the requirements of 8.8.

NOTE Examples of such treatment include potting, encapsulation and vacuum impregnation.

*Compliance is checked in accordance with 13.7, taking into account 8.8 together with the following:*

*A visual inspection shall be carried out to determine that there are no cracks in the encapsulating, impregnating or other material, that coatings have not loosened or shrunk, and after sectioning the sample, that there are no significant voids in the material.*

## 14 Components

### 14.1 General

Where components are part of a range of values it is usually not necessary to test every value within that range. If this range of values consists of several technologically homogeneous subranges, the samples should be representative of each of these subranges. Moreover, it is recommended, where possible, to make use of the concept of structurally similar components.

When a certain flammability category according to IEC 60695-11-10 is required, reference is made to Annex G with respect to alternative test methods.

When no flammability requirements are specified in Clause 14, the requirements of 20.2.5 apply.

NOTE 1 In Australia and New Zealand the special national conditions of Clause 20, Note 2, also apply to all components.

NOTE 2 In Sweden, switches containing mercury such as thermostats, relays and level controllers are not allowed.

### 14.2 Resistors

Resistors, the short-circuiting or disconnecting of which would cause an infringement of the requirements for operation under fault conditions (see Clause 11) and resistors bridging contact gaps of MAINS SWITCHES, shall have an adequate stable resistance value under overload.

Such resistors shall be positioned inside the enclosure of the apparatus.

*Compliance is checked by test a) or test b), carried out on a sample of 10 specimens.*

*Before test a) or b), the resistance of each sample is measured and the sample is then subjected to the damp heat test according to IEC 60068-2-78 with the following severity parameters:*

- *Temperature:  $(40 \pm 2)$  °C,*
- *Humidity:  $(93 \pm 3)$  % RH,*
- *Test duration: 21 days.*

- a) For resistors connected between HAZARDOUS LIVE parts and ACCESSIBLE conductive parts and for resistors bridging contact gaps of MAINS SWITCHES, the 10 specimens are each subjected to 50 discharges at a maximum rate of 12/min, from a 1 nF capacitor charged to 10 kV in a test circuit as shown in Figure 5a.

*After this test, the value of resistance shall not differ more than 20 % from the value measured before the damp heat test.*

*No failure is allowed.*

- b) For other resistors, the 10 specimens are each subjected to a voltage of such a value that the current through it is 1,5 times the value measured through a resistor, having a resistance equal to the specified rated value, which is fitted to the apparatus, when operated under fault conditions. During the test the voltage is kept constant.

*The value of resistance is measured when steady state is attained and shall not differ more than 20 % from the value measured before the damp heat test.*

*No failure is allowed.*

For resistors connected between HAZARDOUS LIVE parts and ACCESSIBLE conductive parts, the CLEARANCES and CREEPAGE DISTANCES between the terminations shall comply with the requirements of Clause 13 for REINFORCED INSULATION.

Resistors with internal end-lead terminations are allowed only if the internal spacings are clearly and precisely defined.

*Compliance is checked by measurement and inspection.*

### **14.3 Capacitors and RC-units**

**14.3.1** Where reference is made to the tests specified in Table 9 of IEC 60384-14:2005, these tests are supplemented as follows:

The duration of the damp heat steady-state test as specified in 4.12 of IEC 60384-14:2005 shall be 21 days.

NOTE Reference is made to IEC 60384-14 irrespective of whether the capacitor or RC-unit is used for electromagnetic interference suppression purposes or not.

**14.3.2** Capacitors or RC-units, the short-circuiting or disconnecting of which would cause an infringement of the requirements under fault conditions with regard to electric shock hazard shall:

- a) withstand the tests for subclass Y2 or Y4 capacitors or RC-units as specified in Table 9 of IEC 60384-14:2005.

Subclass Y2 capacitors or RC-units shall be used for apparatus with rated MAINS voltages > 150 V and ≤ 250 V with respect to earth or neutral respectively.

Subclass Y4 capacitors or RC-units may be used only for apparatus with rated MAINS voltages ≤ 150 V with respect to earth or neutral respectively.

- b) withstand the tests for subclass Y1 or Y2 capacitors or RC-units as specified in Table 9 of IEC 60384-14:2005.

Subclass Y1 capacitors or RC-units shall be used for apparatus with rated MAINS voltages > 150 V and ≤ 250 V with respect to earth or neutral respectively.

Subclass Y2 capacitors or RC-units may be used only for apparatus with rated MAINS voltages ≤ 150 V with respect to earth or neutral respectively.

NOTE For the application of a) and b), reference is made to 8.5 and 8.6.

Such capacitors or RC-units shall be positioned inside the enclosure of the apparatus.

**14.3.3** Capacitors or RC-units having their terminations DIRECTLY CONNECTED TO THE MAINS, shall withstand the tests for subclass X1 or X2 capacitors or RC-units as specified in Table 9 of IEC 60384-14:2005.

Subclass X1 capacitors or RC-units shall be used for PERMANENTLY CONNECTED APPARATUS intended for connection to a MAINS with a nominal voltage > 150 V and ≤ 250 V with respect to earth or neutral respectively.

Subclass X2 capacitors or RC-units may be used for all other applications.

Y2 capacitors or RC-units may be used instead of X1 or X2 capacitors or RC-units.

Y4 capacitors or RC-units may be used instead of X2 capacitors or RC-units in applications ≤150 V.

**14.3.4** Capacitors or RC-units across a secondary winding of a transformer with MAINS frequency output, the short-circuiting of which would cause an infringement of the requirements with regard to overheating, shall withstand the tests for subclass X2 capacitors or RC-units as specified in Table 9 of IEC 60384-14: 2005.

The characteristics of the capacitors or RC-units shall be appropriate for their function in the apparatus under normal operating conditions.

**14.3.5** (Intentionally kept free for future requirements for capacitors or RC-units others than those mentioned in 14.3.2 to 14.3.4).

**14.3.6** Capacitors or RC-units not covered by 14.3.2 to 14.3.5

NOTE If X1 or X2 capacitors or RC-units are used in places other than required in 14.3.3, these X1 or X2 capacitors or RC-units are considered to be covered by 14.3.3 as well.

- a) Capacitors or RC-units with a volume exceeding 1 750 mm<sup>3</sup> used in circuits where, when the capacitor or RC-unit is short-circuited, the current through the short circuit exceeds 0,2 A, shall comply with the PASSIVE FLAMMABILITY requirements according to 4.38 of IEC 60384-1:2008, flammability category B or better.
- b) When the distance between POTENTIAL IGNITION SOURCES and capacitors or RC-units with a volume exceeding 1 750 mm<sup>3</sup> does not exceed the values specified in Table 13, then these capacitors or RC-units shall comply with the relevant PASSIVE FLAMMABILITY requirements according to 4.38 of IEC 60384-1:2008, as specified in Table 13 or better. No PASSIVE FLAMMABILITY requirements apply to these capacitors and RC-units when they are shielded by a barrier as specified in 20.2.5 from the POTENTIAL IGNITION SOURCE.

Subclause 14.3.6 is not applicable to metal-cased capacitors and RC-units. Thin coating or tubing in such a case is ignored.

**Table 13 – Flammability category related to distance from POTENTIAL IGNITION SOURCES**

Open circuit voltage of the POTENTIAL IGNITION SOURCE  V (peak) a.c. or d.c.	Distance from POTENTIAL IGNITION SOURCES to the capacitor or RC-unit downwards or sideways less than <sup>a</sup> mm	Distance from POTENTIAL IGNITION SOURCES to the capacitor or RC-unit upwards less than <sup>a</sup> mm	PASSIVE FLAMMABILITY category according to IEC 60384-1
> 50 and ≤ 4 000	13	50	B
> 4 000	See 20.3		
<sup>a</sup> See Figure 13.			

Compliance is checked according to 4.38 of IEC 60384-1:2008.

## **14.4 Inductors and windings**

### **14.4.1 Requirements**

Inductors and windings shall comply with

- either the requirements of IEC 61558-1 and the relevant parts of IEC 61558-2, with the following addition:  
Insulating material of inductors and windings, except in thin sheet form, shall comply with 20.2.5;
- or with the requirements given below.

NOTE Examples of relevant parts of IEC 61558-2 are:

IEC 61558-2-1: SEPARATING TRANSFORMERS

IEC 61558-2-4: ISOLATING TRANSFORMERS

IEC 61558-2-6: Safety ISOLATING TRANSFORMERS

IEC 61558-2-16: Transformers for switch mode power supplies.

### **14.4.2 Marking**

Inductors the failure of which can impair the safety of an apparatus, for example ISOLATING TRANSFORMERS, shall be marked with the manufacturer's name or trademark and with a type or catalogue reference. The manufacturer's name and the type reference may be replaced by a code number.

*Compliance is checked by inspection.*

### **14.4.3 General**

NOTE 1 Depending on the application in the apparatus attention is drawn to the requirements of 10.2 for the insulation of windings.

ISOLATING TRANSFORMERS shall comply with

- 14.4.4 and
- 14.4.5.1 or 14.4.5.2 and
- 14.4.6.1 or 14.4.6.2.

SEPARATING TRANSFORMERS shall comply with

- 14.4.4 and
- 14.4.5.3 and
- 14.4.6.1 or 14.4.6.2.

Other windings, for example induction motors where the power is supplied to the stator only, degaussing coils, relay coils, autotransformers, shall comply with 14.4.4.1, 14.4.6.1 and 14.4.6.2 as far as applicable.

Transformers for switch mode power supplies (SMPS) shall comply with the requirements of IEC 61558-1 and IEC 61558-2-16, or with the requirements for ISOLATING TRANSFORMERS or for SEPARATING TRANSFORMERS as given above.

Insulating material of inductors and windings, except in thin sheet form, shall comply with 20.2.5.

NOTE 2 For planar transformers, see 2.10.6.4 and Table 2R of IEC 60950-1:2005.

#### 14.4.4 Constructional requirements

##### 14.4.4.1 All windings

CLEARANCES and CREEPAGE DISTANCES shall comply with the requirements of Clause 13.

##### 14.4.4.2 Designs with more than one winding

When an insulation barrier consisting of an uncemented pushed-on partition wall is used, CREEPAGE DISTANCES are measured through the joint. If the joint is covered by an adhesive bonding tape in accordance with the IEC 60454 series, one layer of adhesive bonding tape is required on each side of the wall in order to reduce the risk of tape folding over during production.

The input and output windings shall be electrically separated from each other, and the construction shall be such that there is no possibility of any connection between these windings, either directly or indirectly through conductive parts.

In particular, precautions shall be taken to prevent:

- undue displacement of input or output windings, or the turns thereof;
- undue displacement of internal wiring, or wires for external connections;
- undue displacement of parts of windings, or of internal wiring, in the event of rupture of wires, or loosening of connections; and
- wires, screws, washers and the like from bridging any part of the insulation between the input and output windings, including the connections of windings, should they loosen or become free.

The last turn of each winding shall be retained in a reliable manner, for example by tape, suitable bonding agent, or retention shall be implied by process technology.

Where cheekless bobbins are used, the end turns of each layer shall be retained in a reliable manner. Each layer can, for example, be interleaved with adequate insulation material projecting beyond the end turns of each layer and, moreover, either

- the windings shall be impregnated with hard-baking or cold-setting material, substantially filling the intervening spaces and effectively sealing-off the end turns, or
- the windings shall be held together by means of insulating material, or
- the windings shall, for example, be fixed by process technology.

NOTE It is not expected that two independent fixings will become loose at the same time.

Where serrated tape is used, the serrated part is disregarded as insulation.

*Compliance is checked by inspection.*

##### 14.4.5 Separation between windings

###### 14.4.5.1 Windings of CLASS II construction

The separation between HAZARDOUS LIVE windings and windings intended to be connected to ACCESSIBLE conductive parts shall consist of DOUBLE or REINFORCED INSULATION according to 8.8, except that for coil formers and partition walls providing REINFORCED INSULATION a thickness of at least 0,4 mm without additional requirements applies.

Where an intermediate conductive part, for example the iron core, not intended to be connected to ACCESSIBLE conductive parts is located between the relevant windings, the insulation between these windings via the intermediate conductive part shall consist of DOUBLE or REINFORCED INSULATION as mentioned above.

*Compliance is checked by inspection and by measurement.*

#### **14.4.5.2 Windings of CLASS I construction**

The separation between HAZARDOUS LIVE windings and windings intended to be connected to ACCESSIBLE parts may consist of BASIC INSULATION plus PROTECTIVE SCREENING only if all of the following conditions are complied with:

- the insulation between HAZARDOUS LIVE windings and the protective screen shall comply with the requirements for BASIC INSULATION according to 8.8 dimensioned for the HAZARDOUS LIVE voltage;
- the insulation between the protective screen and non-HAZARDOUS LIVE windings shall comply with the requirements for dielectric strength according to Table 5, item 2;
- the protective screen intended to be connected to a PROTECTIVE EARTHING TERMINAL or contact shall be positioned between the input and output windings in such a way that the screen effectively prevents the input voltage being applied to any output winding in case of an insulation fault;
- the protective screen shall consist of a metal foil or of a wire wound screen extending at least the full width of one of the windings adjacent to the screen. A wire wound screen shall be wound tight without space between the turns;
- the protective screen shall be so arranged that its ends cannot touch each other nor touch simultaneously an iron core, in order to prevent overheating due to creation of a shorted winding;
- the protective screen and its lead-out wire shall have a cross-sectional area sufficient to ensure that if a breakdown of insulation should occur, a fusing or interrupting device will open the circuit before the screen or the lead-out wire is destroyed;
- the lead-out wire shall be connected to the protective screen in a reliable manner, for example by soldering, welding, riveting or crimping.

*Compliance is checked by inspection and by measurement.*

#### **14.4.5.3 Windings of separating construction**

The separation between HAZARDOUS LIVE windings and windings intended to be connected to parts separated from ACCESSIBLE parts by SUPPLEMENTARY INSULATION only shall consist of at least BASIC INSULATION according to 8.8.

*Compliance is checked by inspection and by measurement.*

#### **14.4.6 Insulation between HAZARDOUS LIVE parts and ACCESSIBLE parts**

##### **14.4.6.1 Windings of CLASS II construction**

The insulation:

- between HAZARDOUS LIVE windings and ACCESSIBLE parts or parts intended to be connected to ACCESSIBLE conductive parts, for example an iron core; and
- between HAZARDOUS LIVE parts, for example an iron core connected to a HAZARDOUS LIVE winding, and windings intended to be connected to ACCESSIBLE conductive parts;

shall consist of DOUBLE or REINFORCED INSULATION according to 8.8, except that for coil formers and partition walls providing REINFORCED INSULATION, a thickness of at least 0,4 mm without additional requirements applies.

*Compliance is checked by inspection and measurement.*

#### 14.4.6.2 Windings of CLASS I construction

The insulation:

- between HAZARDOUS LIVE windings and ACCESSIBLE conductive parts or parts intended to be connected to ACCESSIBLE conductive parts connected to a PROTECTIVE EARTHING TERMINAL or contact, for example an iron core; and
- between HAZARDOUS LIVE parts, for example an iron core separated from a HAZARDOUS LIVE winding by functional insulation only, and winding wires or foils of protective screens intended to be connected to a PROTECTIVE EARTHING TERMINAL or contact,

shall consist of BASIC INSULATION according to 8.8.

The winding wires of windings intended to be connected to a PROTECTIVE EARTHING TERMINAL or contact shall have a current carrying capacity sufficient to ensure that, if a breakdown of insulation should occur, a fusing or interrupting device will open the circuit before the winding is destroyed.

*Compliance is checked by inspection and measurement.*

### 14.5 High voltage components and assemblies

#### 14.5.1 General

NOTE For high voltage cables, reference is made to 20.2.3.

Components operating at voltages exceeding 4 kV (peak) and spark gaps provided to protect against overvoltages, if not otherwise covered by 20.2.4, shall not give rise to danger of fire to the surroundings of the apparatus, or to any other hazard within the sense of this standard.

*Compliance is checked by meeting the requirement for category V-1 according to IEC 60695-11-10 or by the test of 14.5.2 and 14.5.3 respectively, in which no failure is allowed.*

#### 14.5.2 High voltage transformers and multipliers

*Three specimens of the transformer with one or more high-voltage windings or of the high-voltage multipliers are subjected to the treatment specified under item a), followed by the test specified under item b).*

##### a) Preconditioning

*For transformers, a power of 10 W (d.c. or a.c. at MAINS frequency) is initially supplied to the high-voltage winding. This power is sustained for 2 min, after which it is increased by successive steps of 10 W at 2 min intervals to 40 W.*

*The treatment lasts 8 min or is terminated as soon as interruption of the winding or appreciable splitting of the protective covering occurs.*

NOTE 1 Certain transformers are so designed that this preconditioning cannot be carried out. In such cases, only the test of item b) below is applied.

*For each specimen of a high-voltage multiplier, its output shall be short-circuited and a voltage taken from an appropriate high-voltage transformer shall be applied to its input.*

*The input voltage is adjusted so that the short-circuit current is initially  $(25 \pm 5)$  mA. This is maintained for 30 min or is terminated as soon as any interruption of the circuit or appreciable splitting of the protective covering occurs.*

NOTE 2 Where the design of a high-voltage multiplier is such that a short-circuit current of 25 mA cannot be obtained, a preconditioning current is used, which represents the maximum attainable current, determined either by the design of the multiplier or by its conditions of use in a particular apparatus.

##### b) Flammability test

*The specimen is subjected to the flammability test of G.1.2, Annex G.*

### **14.5.3 High voltage assemblies and other parts**

#### *Flammability test*

*The specimen is subjected to the flammability test of G.1.2, Annex G.*

### **14.6 Protective devices**

#### **14.6.1 General**

The application of protective devices shall be in accordance with their rated values.

External CLEARANCES and CREEPAGE DISTANCES of protective devices and their connections shall meet the requirements for BASIC INSULATION of Clause 13 for the voltage across the device when opened.

*Compliance is checked by measurement or calculation.*

#### **14.6.2 THERMAL RELEASES**

**14.6.2.1** THERMAL RELEASES used in order to prevent the apparatus from becoming unsafe within the sense of this standard shall comply with 14.6.2.2, 14.6.2.3 or 14.6.2.4 respectively, whichever is applicable.

**14.6.2.2** THERMAL CUT-OUTS shall meet one of the following requirements:

a) The THERMAL CUT-OUT when tested as a separate component, shall comply with the requirements and tests of IEC 60730 series as far as applicable.

For the purpose of this standard, the following applies:

- the THERMAL CUT-OUT shall be of type 2 action (see 6.4.2 of IEC 60730-1:2010);
- the THERMAL CUT-OUT shall have at least MICRO-DISCONNECTION (type 2B) (see 6.4.3.2 and 6.9.2 of IEC 60730-1:2010);
- the THERMAL CUT-OUT shall have a TRIP-FREE mechanism in which contacts cannot be prevented from opening against a continuation of a fault (type 2E) (see 6.4.3.5 of IEC 60730-1:2010);
- the number of cycles of automatic action shall be at least
  - 3 000 cycles for THERMAL CUT-OUTS with automatic reset used in circuits which are not switched-off when the apparatus is switched-off (see 6.11.8 of IEC 60730-1:2010),
  - 300 cycles for THERMAL CUT-OUTS with automatic reset used in circuits which are switched-off together with the apparatus and for THERMAL CUT-OUTS with no automatic reset which can be reset BY HAND from the outside of the apparatus (see 6.11.10 of IEC 60730-1:2010),
  - 30 cycles for THERMAL CUT-OUTS with no automatic reset and which cannot be reset BY HAND from the outside of the apparatus (see 6.11.11 of IEC 60730-1:2010);
- the THERMAL CUT-OUT shall be tested as designed for a long period of electrical stress across insulating parts (see 6.14.2 of IEC 60730-1:2010);
- the THERMAL CUT-OUT shall meet the ageing requirements for an intended use of at least 10 000 h (see 6.16.3 of IEC 60730-1:2010); and
- with regard to the dielectric strength, the THERMAL CUT-OUT shall meet the requirements of 10.4 of this standard, except across the contact gap, and except between terminations and connecting leads of the contacts, for which 13.2 to 13.2.4 of IEC 60730-1:2010 applies.

The characteristics of the THERMAL CUT-OUT with regard to:

- the ratings of the THERMAL CUT-OUT (see Clause 5 of IEC 60730-1:2010);

- the classification of the THERMAL CUT-OUT according to
  - nature of supply (see 6.1 of IEC 60730-1:2010),
  - type of load to be controlled (see 6.2 of IEC 60730-1:2010),
  - degree of protection provided by enclosures against ingress of solid objects and dust (see 6.5.1 of IEC 60730-1:2010),
  - degree of protection provided by enclosures against harmful ingress of water (see 6.5.2 of IEC 60730-1:2010),
  - pollution situation for which the THERMAL CUT-OUT is suitable (see 6.5.3 of IEC 60730-1:2010), and
  - maximum ambient temperature limit (see 6.7 of IEC 60730-1:2010);

shall be appropriate for the application in the apparatus under normal operating conditions and under fault conditions.

*Compliance is checked according to the test specifications of IEC 60730 series, by inspection and by measurement.*

- b) The THERMAL CUT-OUT, when tested as a part of the apparatus shall
- have at least MICRO-DISCONNECTION according to IEC 60730-1, withstanding a test voltage according to 13.2 of IEC 60730-1:2010, and
  - have a TRIP-FREE mechanism in which contacts cannot be prevented from opening against a continuation of a fault, and
  - be aged for 300 h at a temperature corresponding to the ambient temperature of the THERMAL CUT-OUT when the apparatus is operated under normal operating conditions at an ambient temperature of 35 °C (45 °C for apparatus intended for use in tropical climates), and
  - be subjected to a number of cycles of automatic action as specified under a) for a THERMAL CUT-OUT tested as a separate component, by establishing the relevant fault conditions.

The test is made on three specimens.

No sustained arcing shall occur during the test.

After the test, the THERMAL CUT-OUT shall show no damage in the sense of this standard. In particular, it shall show no deterioration of its enclosure, no reduction of CLEARANCES and CREEPAGE DISTANCES and no loosening of electrical connections or mechanical fixings.

*Compliance is checked by inspection and by the specified tests in the given order.*

**14.6.2.3** THERMAL LINKS shall meet one of the following requirements:

- a) The THERMAL LINK, when tested as a separate component, shall comply with the requirements and tests of IEC 60691.

The characteristics of the THERMAL LINK shall be appropriate for the application in the apparatus under normal operating conditions and under fault conditions.

The dielectric strength of the THERMAL LINK shall meet the requirements of 10.3 of this standard except across the disconnection (contact parts) and except between terminations and connecting leads of the contacts, for which 10.4 of IEC 60691:2002 applies.

*Compliance is checked according to the test specifications of IEC 60691, by inspection and measurement.*

- b) The THERMAL LINK, when tested as a part of the apparatus shall be
- aged for 300 h at a temperature corresponding to the ambient temperature of the THERMAL LINK when the apparatus is operated under normal operating conditions at an ambient temperature of 35 °C (45 °C for apparatus intended for use in tropical climates), and
  - subjected to such fault conditions of the apparatus which cause the THERMAL LINK to operate. During the test, no sustained arcing and no damage in the sense of this standard shall occur, and



The marking requirements apply also if the fuse has a rated current outside the range specified in IEC 60127.

*Compliance is checked by inspection.*

**14.6.3.3** Fuse holders, so designed that a fuse can be connected in parallel in the same circuit, shall not be used.

*Compliance is checked by inspection.*

**14.6.3.4** If HAZARDOUS LIVE parts are rendered ACCESSIBLE during replacement of fusing or interrupting devices, access to such parts shall not be possible BY HAND operation.

Fuse-holders for miniature cartridge fuses of the screw-in or bayonet type shall, if removal of the fuse-carrier BY HAND is possible from the outside of the apparatus, be so constructed that HAZARDOUS LIVE parts do not become ACCESSIBLE, either during insertion or removal of the fuse, or after the fuse has been removed. Fuse holders in compliance with IEC 60127-6 satisfy this requirement.

When the fuse carrier is constructed to hold the fuse, the fuse is placed in the fuse-carrier during the test.

*Compliance is checked by inspection.*

#### **14.6.4 PTC THERMISTORS**

PTC THERMISTORS used in order to prevent the apparatus from becoming unsafe within the sense of this standard shall comply with:

- Clauses 15, 17, J.15 and J.17 of IEC 60730-1:2010; or
- IEC 60730-1 for a device providing Type 2.AL action.

*Compliance is checked by inspection and by the tests of 11.2 of this standard.*

For PTC THERMISTORS whose power dissipation exceeds 15 W for the rated zero-power resistance at an ambient temperature of 25 °C, the encapsulation or tubing shall comply with the flammability category V-1 or better according to IEC 60695-11-10.

*Compliance is checked according to IEC 60695-11-10 or according to G.1.2 of Annex G.*

#### **14.6.5 Protective devices not mentioned in 14.6.2, 14.6.3 or 14.6.4**

Such protective devices, for example fusing resistors, fuses not standardized in IEC 60127 or miniature circuit breakers, shall have adequate breaking capacity.

For non-resettable protective devices, such as fuses, a marking shall be located close to the protective device, so that correct replacement is possible.

*Compliance is checked by inspection and during the tests under fault conditions (see 11.2).*

*The test under fault condition is carried out three times.*

*No failure is allowed.*

## **14.7 Switches**

### **14.7.1 MANUALLY OPERATED MECHANICAL SWITCHES which**

- control currents exceeding 0,2 A r.m.s. a.c. or d.c., and/or
- have voltage across the open switch contacts exceeding 35 V (peak) a.c. or 24 V d.c.

shall meet one of the following requirements:

- a) The switch tested as a separate component, shall comply with the requirements and tests of IEC 61058-1, whereby the following applies:
- the number of operating cycles shall be 10 000 (see 7.1.4.4 of IEC 61058-1:2000);
  - the switch shall be suitable for use in a normal pollution situation (see 7.1.6.2 of IEC 61058-1:2000);
  - deviating from 13.1 of IEC 61058-1:2000, for a.c. and d.c. MAINS SWITCHES built in CRT TV's, the speed of contact making and breaking shall be independent of the speed of actuation.

NOTE Reason is the high inrush current due to the degaussing coil.

- MAINS SWITCHES shall comply with the flammability category V-0 or according to G.1.1 of Annex G.

The characteristics of the switch with regard to:

- the ratings of the switch (see Clause 6 of IEC 61058-1:2000); and
- the classification of the switch according to:
  - nature of supply (see 7.1.1 of IEC 61058-1:2000),
  - type of load to be controlled by the switch (see 7.1.2 of IEC 61058-1:2000),
  - ambient air temperature (see 7.1.3 of IEC 61058-1:2000);

shall be appropriate for the function of the switch under normal operating conditions.

*Compliance is checked according to test specifications of IEC 61058-1, by inspection and by measurements.*

*If the switch is a MAINS SWITCH which controls MAINS socket-outlets, the total rated current and the peak surge current of the socket-outlets as specified in 14.7.5 shall be taken into account for the measurement.*

- b) The switch tested as part of the apparatus working under normal operating conditions, shall meet the requirements of 14.7.2, 14.7.5 and 20.2.5, and moreover:
- switches controlling currents exceeding 0,2 A r.m.s. a.c. or d.c. shall meet the requirements of 14.7.3 and 14.7.4 if the voltage across the open switch contacts exceeds 35 V (peak) a.c. or 24 V d.c.;
  - switches controlling currents exceeding 0,2 A r.m.s. a.c. or d.c. shall meet the requirements of 14.7.3 if the voltage across the open switch contacts does not exceed 35 V (peak) a.c. or 24 V d.c.;
  - switches controlling currents up to 0,2 A r.m.s. a.c. or d.c. shall meet the requirements of 14.7.4 if the voltage across the open switch contacts exceeds 35 V (peak) a.c. or 24 V d.c.; and
  - MAINS SWITCHES shall comply with G.1.1 of Annex G.

**14.7.2** A switch tested according to 14.7.1 b) shall withstand, without excessive wear or other harmful effects, the electrical, thermal and mechanical stresses that occur during intended use.

*Compliance is checked according to 13.1 of IEC 61058-1:2000, and by the following endurance test:*

The switch is subjected to 10 000 cycles of operation with a sequence according to 17.1.2 of IEC 61058-1:2000, excluding the increased-voltage test at accelerated speed specified in 17.2.4 of IEC 61058-1:2000, and under electrical and thermal conditions given by the normal operating conditions of the apparatus.

The test is made on three specimens, no failure is allowed.

**14.7.3** A switch tested according to 14.7.1 b) shall be so constructed that it does not attain excessive temperatures during intended use. The materials used shall be such that the performance of the switch is not adversely affected by the operation during intended use of the apparatus. In particular, the material and design of the contacts and terminations shall be such that their oxidation or other deterioration does not adversely affect the operation and performance of the switch.

Compliance is checked in the on-position under normal operating conditions and according to 16.2.2.d), l) and m) of IEC 61058-1:2000, taking into account the total rated current  $I$  of MAINS socket-outlets, if any, and the peak surge current according to 14.7.5.

The temperature rise at the terminations shall not exceed 55 K during this test.

**14.7.4** A switch tested according to 14.7.1 b) shall have adequate dielectric strength.

Compliance is checked by the following tests:

The switch shall withstand a dielectric strength test as specified in 10.4, without being previously subjected to the humidity treatment, the test voltage being decreased to 75 % of the corresponding test voltage specified in 10.4, but not less than 500 V r.m.s. (700 V peak).

- The test voltage is applied in the on-position between HAZARDOUS LIVE parts and ACCESSIBLE conductive parts or parts which are connected to ACCESSIBLE conductive parts, and in addition between the poles in case of a multipole switch.
- The test voltage is applied in the off-position across each contact gap. During the test, resistors, capacitors and RC-units in parallel to a contact gap may be disconnected.

**14.7.5** If the switch is a MAINS SWITCH which controls MAINS socket-outlets, the endurance test is carried out with an additional load connected to the socket-outlets, consisting of the circuit shown in Figure 9 of IEC 61058-1:2000, taking into account Figure 10 of IEC 61058-1:2000.

The total rated current of the additional load shall correspond to the marking of the socket-outlets, see 5.3 c). The peak surge current of the additional load shall have a value as shown in Table 14.

**Table 14 – Peak surge current**

Total rated current of the socket-outlets controlled by the switch A	Peak surge current A
Up to and including 0,5	20
Over 0,5 up to and including 1,0	50
Over 1,0 up to and including 2,5	100
Over 2,5	150

After the test, the switch shall show no damage in the sense of this standard. In particular, it shall show no deterioration of its enclosure, no reduction of CLEARANCES and CREEPAGE DISTANCES and no loosening of electrical connections or mechanical fixings.

*Compliance is checked by inspection and by the tests specified in 14.7.3 and/or 14.7.4 in the given order.*

#### **14.8 SAFETY INTERLOCKS**

SAFETY INTERLOCKS shall be provided where access BY HAND is possible to areas presenting hazards in the sense of this standard.

For requirements and test specifications reference is made to 2.8 of IEC 60950-1:2005, Amendment 1:2009.

#### **14.9 Voltage setting devices and the like**

The apparatus shall be so constructed that changing the setting from one voltage to another or from one nature of supply to another is unlikely to occur accidentally.

*Compliance is checked by inspection and by manual test.*

*Changing of the setting which necessitates consecutive movements BY HAND is considered to comply with this requirement.*

#### **14.10 Motors**

**14.10.1** Motors shall be so constructed as to prevent, in prolonged intended use, any electrical or mechanical failure impairing compliance with this standard. The insulation shall not be affected and contacts and connections shall be such that they do not work loose by heating, vibration, etc.

*Compliance is checked by the following tests carried out on the apparatus under normal operating conditions.*

- a) *The apparatus is connected to 1,1 times the RATED SUPPLY VOLTAGE and to 0,9 times the RATED SUPPLY VOLTAGE, each time for 48 h. Motors for short-time or intermittent operation are connected for periods in accordance with the operating time if limited by the construction of the apparatus.*

*In case of short-time operation, suitable cooling intervals are inserted.*

NOTE 1 It can be convenient to carry out this test immediately after the test of 7.1.

- b) *The motor is started 50 times while the apparatus is connected to 1,1 times the RATED SUPPLY VOLTAGE and 50 times while connected to 0,9 times the RATED SUPPLY VOLTAGE, each period of connection being at least 10 times the period from start to full speed, but not less than 10 s.*

*The intervals between starts shall be not less than three times the period of connection.*

*If the apparatus provides for more than one speed, the test is carried out at the most unfavourable speed.*

*After these tests, the motor shall withstand the dielectric strength of 10.4, no connection shall have loosened and there shall be no deterioration impairing the safety.*

NOTE 2 For induction motors with power supplied to the stator only, see also 14.4.3.

**14.10.2** Motors shall be so constructed or mounted that wiring, windings, commutators, slip-rings, insulations, etc., are not adversely affected by oil, grease or other substances to which they are exposed during intended use.

*Compliance is checked by inspection.*

**14.10.3** Moving parts liable to cause personal injury shall be so arranged or enclosed as to provide adequate protection against this danger during intended use. Protective enclosures, guards and the like shall have adequate mechanical strength. They shall not be removable BY HAND.

*Compliance is checked by inspection and by manual test.*

**14.10.4** In addition, for motors having phase-shifting capacitors, three-phase motors and series motors of IEC 60950-1:2005, Annex B, Clauses B.8, B.9 and B.10 apply.

## **14.11 Batteries**

### **14.11.1 General**

Portable secondary sealed cells and batteries (other than button) containing alkaline or other non-acid electrolyte shall comply with IEC 62133.

Batteries shall be so mounted that there is no risk of the accumulation of flammable gases and that the leakage of electrolyte cannot impair any insulation.

*Compliance is checked by inspection.*

### **14.11.2 User replaceable rechargeable batteries**

If it is possible for the USER to replace rechargeable batteries, which can be recharged in the apparatus, by non-rechargeable batteries, special means, such as a separate charging contact on a rechargeable special battery-pack or an electronic protective circuit, shall be provided to avoid any current being supplied into the non-rechargeable batteries.

This requirement does not apply to batteries inside the apparatus, the replacement of which by the USER is not intended, for example batteries for memories.

*Compliance is checked by inspection.*

NOTE Additional requirements regarding the instructions for use are given in 5.5.2.

### **14.11.3 Battery use**

Under normal operating conditions and under fault conditions,

- for rechargeable batteries, the charging current,
- for lithium batteries, the discharging current and the reverse current,

shall not exceed the permissible values given by the battery manufacturer.

*Compliance is checked by measurement.*

*Lithium batteries shall be removed from the circuit and replaced by a voltage source when measuring discharging currents and by a short circuit when measuring reverse current.*

### **14.11.4 Battery mould stress relief**

A SPECIAL BATTERY not covered by IEC 62133, in which containment of the electrolyte is dependent upon a thermoplastic material, shall not release electrolyte due to stresses caused by the moulding process if the electrolyte can contact insulation or enter a USER-serviceable compartment.

*Compliance is checked by the following test.*

*The battery is to be placed in an air-circulating oven, maintained at a temperature of 70 °C, for a period of 7 h. Following the oven conditioning, the battery shall be examined for electrolyte that has been released.*

#### **14.11.5 Battery drop test**

A USER-serviceable SPECIAL BATTERY not covered by IEC 62133 shall not release electrolyte as a result of being dropped.

*Compliance is checked by the following test.*

*Three samples are each to be subjected to a single drop through a distance of 1 m to strike a hardwood surface as described in 15.4.3. Following the drop test, each battery is to be examined for electrolyte that has been released.*

#### **14.12 Optocouplers**

Optocouplers shall comply with the constructional requirements of Clause 8.

CLEARANCES and CREEPAGE DISTANCES external to the optocoupler shall comply with 13.1.

For optocouplers with an internal insulating compound completely filling the casing of the optocoupler, no internal CLEARANCES and CREEPAGE DISTANCES are required.

For all other optocouplers, the internal CLEARANCES and CREEPAGE DISTANCES shall comply with 13.1.

There is no minimum distance through insulation for SUPPLEMENTARY INSULATION or REINFORCED INSULATION consisting of an insulating compound completely filling the casing of an optocoupler, provided that the component:

- a) passes
  - the TYPE TESTS and inspection criteria of 13.6; and
  - ROUTINE TESTS for dielectric strength during manufacturing according to N.3.2, using the appropriate value of the test voltage in 10.4.2 applied for 1 s; or
- b) complies with the requirements of IEC 60747-5-5, where the test voltages specified in 5.2.7 of IEC 60747-5-5:2007, including Amendment 1:2013, shall be at least the appropriate test voltage in 10.4.2 of this standard:
  - the voltage  $V_{ini,a}$  for TYPE TESTING; and
  - the voltage  $V_{ini,b}$  for ROUTINE TESTING applied for 1 s; or
- c) complies with 13.8, if applicable.

#### **14.13 Surge suppression varistors**

Surge suppression varistors used in order to prevent MAINS overvoltages coming into the apparatus shall comply with IEC 61051-2.

Such components shall not be connected between parts connected to the MAINS and ACCESSIBLE conductive parts or parts connected to them, except for earthed parts of PERMANENTLY CONNECTED APPARATUS.

Where a varistor in series with a Gas Discharge Tube (GDT) is used to bridge BASIC INSULATION, the following applies:

- the varistor has to comply with IEC 61051-2 as indicated below; and
- the GDT has to comply with:

- the electric strength test for BASIC INSULATION; and
- the external CLEARANCE and CREEPAGE DISTANCE requirements for BASIC INSULATION.

Reference is made to IEC 61051-2 where the following requirements apply:

- preferred climatic categories (2.1.1 of IEC 61051-2:1991)

- maximum lower temperature:  $-10\text{ }^{\circ}\text{C}$
- minimum upper temperature:  $+85\text{ }^{\circ}\text{C}$
- minimum duration of climatic tests: 21 days

- maximum continuous voltages (2.1.2 of IEC 61051-2:1991)

The minimum value of the maximum continuous a.c. voltage shall be 1,2 times the RATED SUPPLY VOLTAGE of the apparatus.

- current pulse rating (2.1.2 of IEC 61051-2:1991)

Surge suppression varistors shall withstand a combination pulse of 6 kV/3 kA with voltage waveform of 1,2/50  $\mu\text{s}$  and current waveform of 8/20  $\mu\text{s}$ .

As an alternative, the combination pulse test of IEC 61051-2:1991, Amendment 1:2009 (2.3.6, Table I, group 1 and Annex A), including consideration of the nominal MAINS voltage and overvoltage category, is acceptable.

*Compliance is checked by applying the test of IEC 61051-2, group 1. After the test, the varistor voltage (as defined in IEC 61051) shall not have changed by more than 10 % when measured with the manufacturer's specified current.*

- fire hazard (IEC 61051-2, Table I, group 6)

The coating of surge suppression varistors shall have a flammability category V-0 or better according to IEC 60695-11-10.

*Compliance is checked according to IEC 60695-11-10 or according to G.1.1 of Annex G.*

- thermal stress

For apparatus with nominal MAINS voltage of  $< 150\text{ V}$ , the apparatus and a test resistor connected in series with the apparatus shall be energised from an a.c. source of 250 V.

The voltage source shall be applied for 4 h or until the circuit path through the varistor opens for each of the test series resistance values: 2 000  $\Omega$ , 500  $\Omega$ , 250  $\Omega$ , 50  $\Omega$ . A separate apparatus shall be used for each resistor value, unless damage from the previous test has been repaired.

*At the end of each test, the apparatus shall comply with Clause 11.*

## 15 TERMINALS

### 15.1 Plugs and sockets

**15.1.1** Plugs and appliance couplers for the connection of the apparatus to the MAINS and socket-outlets and interconnection couplers for providing MAINS power to other apparatus shall comply with the relevant IEC standards for plugs and socket-outlets, appliance couplers or interconnection couplers.

Examples of the relevant IEC publications are: IEC 60083, IEC 60320, IEC 60884 and IEC 60906.

NOTE 1 In Australia, Denmark, Israel, Japan, New Zealand, South Africa, Switzerland and the United Kingdom, special national conditions are valid for plugs and socket-outlets.

NOTE 2 In South Africa, where a cordset is used as the means of connection to the supply MAINS, this cordset may be provided with a rewirable plug, provided that the plug complies with the national regulations.

MAINS socket-outlets and interconnection couplers mounted on CLASS II apparatus shall only permit connection of other CLASS II apparatus.

MAINS socket-outlets and interconnection couplers mounted on CLASS I apparatus shall either allow connection of CLASS II apparatus only or shall be provided with protective earthing contacts which are reliably connected to the PROTECTIVE EARTHING TERMINAL or contact of the apparatus.

For CLASS I apparatus, provision for both kinds of socket-outlets and interconnection couplers is allowed on the same apparatus.

NOTE 3 Socket-outlets allowing only the connection of CLASS II apparatus can be designed, for instance, similar to IEC 60906-1:2009, standard sheets 3-1 or 3-2, or according to IEC 60320-2-2:1998, standard sheets D or H.

For apparatus with socket-outlets providing MAINS power to other apparatus, measures shall be taken to ensure that plugs or appliance inlets for the connection of the apparatus to the MAINS cannot be overloaded, if the rated current of the plug or appliance connector is less than 16 A.

NOTE 4 For marking of the socket-outlets, see 5.3 c).

Conductors of internal wiring of socket-outlets providing MAINS power to other apparatus either directly or via a MAINS SWITCH shall have a nominal cross-sectional area as specified in 16.2 for external flexible cords, except where the apparatus complies with Clause 11 when 4.3.10 is applied.

*Compliance is checked according to the relevant standards, by inspection and according to 16.2.*

**15.1.2** Connectors other than for connecting MAINS power shall be so designed that the plug or socket has such a shape that connection to a MAINS socket outlet, appliance coupler or MAINS connector is unlikely to occur.

This requirement does not apply to connectors forming part of a non-detachable cord which are not CONDUCTIVELY CONNECTED TO THE MAINS, unless ACCESSIBLE conductive parts become HAZARDOUS LIVE during or after insertion of the connector into the MAINS socket-outlet.

NOTE Examples of connectors meeting this requirement are those constructed according to IEC 60130-2, IEC 60130-9, IEC 60169-2 or IEC 60169-3, when used as prescribed. An example of a connector not meeting the requirements is the so-called "banana" plug.

Sockets for audio and video circuits of LOAD TRANSDUCERS indicated with the symbol of 5.3 b) shall be so designed, that a plug for antenna and earth, for audio and video circuits of LOAD TRANSDUCERS and SOURCE TRANSDUCERS and for data and similar circuits which are not indicated with the symbol of 5.3 b), cannot be inserted into them.

*Compliance is checked by inspection.*

**15.1.3** TERMINALS and connectors used in output circuits of SUPPLY APPARATUS, whose output voltage is not a standard nominal MAINS voltage according to IEC 60038:2009, Table I, shall not be compatible with those specified for household and similar general purposes, for example those described in IEC 60083, IEC 60320, IEC 60884, IEC 60906.

*Compliance is checked by inspection and by manual tests.*

The TERMINAL or connector shall be designed for the loading which may appear under normal operating conditions and during intended use.

*Compliance is checked according to the IEC 60320 series as far as safety is concerned, for instance with regard to shock hazard and heating.*

## 15.2 Provisions for protective earthing

ACCESSIBLE conductive parts of CLASS I apparatus, which might assume a hazardous voltage in the event of a single insulation fault in BASIC INSULATION, and the protective earthing contacts of socket-outlets shall be reliably connected to a PROTECTIVE EARTHING TERMINAL within the apparatus.

Solder alone shall not serve as the sole means to provide mechanical securement of the protective conductor.

The protective conductor termination shall be made such that it is not likely to be loosened during servicing, other than servicing of the conductor itself. The protective earthing conductor termination shall not serve as a means to fix any other component.

Protective earthing circuits shall not contain switches or fuses.

Protective earthing conductors may be bare or insulated. If insulated, the insulation shall be green/yellow except in the following two cases:

- a) for earthing braids, the insulation shall be either green/yellow or transparent;
- b) for internal protective conductors in assemblies such as ribbon cables, busbars, flexible printed wiring, etc., any colour may be used provided that no misinterpretation of the use of the conductor is likely to arise.

Wires identified by the colour combination green/yellow shall be used only for protective earthing connections.

For PERMANENTLY CONNECTED APPARATUS and for apparatus provided with a non-detachable flexible cord or cable, a separate PROTECTIVE EARTHING TERMINAL shall be used, located adjacent to the MAINS TERMINALS, and shall comply with the requirements of 15.3.

If parts removable BY HAND have a protective earthing connection, this connection shall be made before the current-carrying connections are established when placing the part in position, and the current-carrying connections shall be separated before the protective earthing connection is interrupted when removing the part.

Conductive parts in contact with protective earthing connections shall not be subject to significant corrosion due to electrochemical action. Combinations above the line in Annex F shall be avoided.

The PROTECTIVE EARTHING TERMINAL shall be resistant to significant corrosion.

NOTE 1 Corrosion resistance can be achieved by a suitable plating or coating process.

*Compliance is checked by inspection and by reference to the table of electro-chemical potentials in Annex F.*

The resistance of the connection between the PROTECTIVE EARTHING TERMINAL or contact, and parts required to be connected thereto, shall not exceed 0,1  $\Omega$ .

*Compliance is checked by the following test:*

*The test shall be carried out for 1 min with a test current of 25 A a.c. or d.c. The test voltage shall not exceed 12 V.*

NOTE 2 In Canada, a 30 A test current is used.

*The voltage drop between the PROTECTIVE EARTHING TERMINAL or contact and the part to be connected thereto shall be measured and the resistance is calculated from the current and this voltage drop. The resistance of the protective earthing conductor of the power supply cord shall not be included in the resistance measurement.*

### **15.3 TERMINALS for external flexible cords and for permanent connection to the MAINS supply**

**15.3.1** PERMANENTLY CONNECTED APPARATUS shall be provided with TERMINALS in which connection is made by means of screws, nuts or equally effective devices, for example screwless type clamping units according to IEC 60998-2-2 or TERMINALS according to IEC 60999-1 and IEC 60999-2.

*Compliance is checked by inspection.*

*For inlet openings, reference is made to IEC 60335-1.*

**15.3.2** For apparatus with non-detachable MAINS supply cords, the connection of the individual conductors to the internal wiring of the apparatus shall be accomplished by any means that will provide a reliable electrical and mechanical connection, except that the supply conductors and the protective earthing conductor of a non-detachable MAINS cord or cable shall not be soldered directly to the conductors of a PRINTED BOARD.

Soldered, crimped and similar connections may be used for the connection of external conductors. For soldered or crimped connections, barriers shall be provided so that CLEARANCES and CREEPAGE DISTANCES cannot be reduced to less than the values specified in Clause 13 and Annex J respectively, should the conductor break away at a soldered joint or slip out of a crimped connection. Alternatively, the conductors shall be positioned or fixed in such a way that reliance is not placed upon the connection alone to maintain the conductors in position.

*Compliance is checked by inspection, and, in case of doubt, by applying a pull of 5 N in any direction to the connection.*

**15.3.3** Screws and nuts which clamp external MAINS supply conductors shall have a thread conforming to ISO 261 or ISO 262, or a thread comparable in pitch and mechanical strength. They shall not serve to fix any other component, except that they may also clamp internal conductors if these are so arranged that they are unlikely to be displaced when fitting the MAINS supply conductors.

Terminations of a component (for example a switch) built into the apparatus and used as TERMINALS for the supply of MAINS power to the apparatus shall comply with the requirements of 15.3.1.

*Compliance is checked by inspection.*

**15.3.4** For the purpose of applying the requirements for MAINS supply cords:

- it is assumed that two independent fixings will not become loose at the same time;
- conductors connected by soldering are not considered to be adequately fixed unless they are held in place near to the termination, independently of the solder. However "hooking-in" before the soldering is, in general, considered to be a suitable means for maintaining the conductors of a MAINS supply cord in position, provided that the hole through which the conductor is passed is not unduly large; and
- conductors connected to TERMINALS or terminations by other means are not considered to be adequately fixed unless an additional fixing is provided near to the TERMINAL or termination; this additional fixing may clamp both the insulation and the conductor.

**15.3.5** TERMINALS for external flexible cords shall allow the connection of conductors having nominal cross-sectional areas as shown in Table 15.

For rated currents exceeding 16 A, reference is made to IEC 60950-1:2005, Table 3D.

*Compliance is checked by inspection, by measurement and by fitting cords of the smallest and largest cross-sectional areas of the appropriate range shown in Table 15.*

**Table 15 – Nominal cross-sectional area to be accepted by TERMINALS**

RATED CURRENT CONSUMPTION of the apparatus <sup>a</sup> A	Nominal cross-sectional area mm <sup>2</sup>	
	Up to and including 3	0,5
Over 3 up to and including 6	0,75	to 1
Over 6 up to and including 10	1	to 1,5
Over 10 up to and including 16	1,5	to 2,5

<sup>a</sup> The RATED CURRENT CONSUMPTION includes currents which can be drawn from socket-outlets providing MAINS power for other apparatus.

**15.3.6** TERMINALS according to 15.3.3 shall have minimum sizes as shown in Table 16.

Stud TERMINALS shall be provided with washers.

For rated currents over 16 A, reference is made to IEC 60950-1, Amendment 2:2013 Table 3E.

*Compliance is checked by measurement and inspection.*

**Table 16 – Minimum nominal thread diameter**

RATED CURRENT CONSUMPTION of the apparatus <sup>a</sup> A	Minimum nominal thread diameter mm	
	Pillar type or stud type	Screw type
Up to and including 10	3	3,5
Over 10 up to and including 16	3,5	4

<sup>a</sup> The RATED CURRENT CONSUMPTION includes currents which can be drawn from socket-outlets providing MAINS power for other apparatus.

**15.3.7** TERMINALS shall be so designed that they clamp the conductor between metal surfaces with sufficient contact pressure and without damage to the conductor.

TERMINALS shall be so designed or located that the conductor cannot slip out when the clamping screws or nuts are tightened.

TERMINALS shall be so fixed that, when the means of clamping the conductor is tightened or loosened,

- the TERMINAL itself does not work loose;
- internal wiring is not subjected to stress; and
- CLEARANCES and CREEPAGE DISTANCES are not reduced below the values specified in Clause 13 and Annex J.

*Compliance is checked by inspection and measurement.*

**15.3.8** TERMINALS in circuits carrying a current exceeding 0,2 A under normal operating conditions shall be so designed that contact pressure is not transmitted through insulating material other than ceramic, unless there is sufficient resiliency in the metallic parts to compensate for any possible shrinkage of the insulating material.

*Compliance is checked by inspection.*

**15.3.9** For non-detachable MAINS supply cords, each TERMINAL shall be located in proximity to its corresponding TERMINALS of different potential and to the PROTECTIVE EARTHING TERMINAL, if any.

*Compliance is checked by inspection.*

TERMINALS shall be so located, guarded or insulated that, should a strand of a flexible conductor escape when the conductor is fitted, there is no risk of accidental contact between such a strand and:

- ACCESSIBLE conductive parts or conductive parts connected to them; and
- conductive parts not connected to the PROTECTIVE EARTHING TERMINAL and separated from ACCESSIBLE conductive parts by SUPPLEMENTARY INSULATION only.

*Compliance is checked by inspection and, unless a special cord is prepared in such a way as to prevent the escape of strands, by the following test.*

*An 8 mm length of insulation shall be removed from the end of a flexible conductor having the appropriate nominal cross-sectional area. One wire of the stranded conductor shall be left free and the other wires shall be fully inserted into, and clamped in the TERMINAL.*

*Without tearing the insulation back, the free wire shall be bent in every possible direction, but without making sharp bends round a guard.*

*If the conductor is HAZARDOUS LIVE, the free wire shall not touch any conductive part which is ACCESSIBLE or is connected to an ACCESSIBLE conductive part or, in the case of apparatus with DOUBLE INSULATION, any conductive part which is separated from ACCESSIBLE conductive parts by SUPPLEMENTARY INSULATION only.*

*If the conductor is connected to an earthing TERMINAL, the free wire shall not touch any HAZARDOUS LIVE part.*

#### **15.4 Devices forming a part of the MAINS plug**

**15.4.1** A device provided with pins intended to be introduced into fixed socket-outlets shall not impose undue strain on these socket-outlets.

*Compliance is checked by engaging the device, as during intended use, with the socket-outlet of a test apparatus as shown in Figure 11. The balancing arm of the test apparatus pivots about a horizontal axis through the centre lines of the contact tubes of the socket-outlet at a distance of 8 mm behind the engagement face of the socket-outlet.*

*With the device not in engagement, the balancing arm is in equilibrium, the engagement face of the socket-outlet being in the vertical position.*

*After the device has been engaged, the torque to be applied to the socket-outlet to maintain its engagement face in the vertical plane is determined by the position of a weight on the balancing arm. The torque shall not exceed 0,25 Nm.*

NOTE 1 This test is compatible with the test described in IEC 60884-1.

NOTE 2 The testing device shown in Figure 11 is intended for the testing of devices forming a part of the MAINS plug. Examples of MAINS plugs are given in IEC 60083. For devices forming a part of the MAINS plug with other dimensions, other testing devices and requirements can be necessary.

**15.4.2** The MAINS plug part of the device shall comply with the standards for the dimensions of MAINS plugs. The overall shape of the device shall be such, that it cannot be mistaken as a standard MAINS plug.

*Compliance is checked by measurement in accordance with the relevant standard.*

NOTE The dimensions of some types of MAINS plugs are given in IEC 60083. For any particular plug, check the current edition of any relevant national standard.

**15.4.3** The device shall have adequate mechanical strength.

*Compliance is checked by inspection and by the following tests:*

a) *The device shall be subjected to a drop test.*

*A sample of the complete device shall be subjected to three impacts that result from being dropped 1 m on to a horizontal surface in positions likely to produce the most adverse results.*

*The horizontal surface shall consist of hardwood of at least 13 mm thick, mounted on two layers of plywood each 19 mm to 20 mm thick, all supported on a concrete or equivalent non-resilient floor.*

*After the test, the specimen shall comply with the requirements of this standard, but it need not be operational.*

*Small pieces may be broken off, provided that the protection against electric shock is not affected.*

*Distortion of pins and damage to the finish and small dents which do not reduce the CLEARANCES or CREEPAGE DISTANCES below the values specified in Clause 13, are neglected.*

b) *The pins shall not turn when a torque of 0,4 Nm is applied, first in one direction for 1 min and then in the opposite direction for 1 min.*

NOTE This test is not carried out if rotation of the pins does not impair safety in the sense of this standard.

c) *A pull force as given in Table 17 is applied, without jerks, for 1 min on each pin in turn, in the direction of the longitudinal axis of the pin.*

*The pull force is applied within a heating cabinet at a temperature of (70 ± 2) °C, 1 h after the device has been placed in the heating cabinet.*

*After the test, the device is allowed to cool down to ambient temperature and no pin shall have been displaced in the body of the device by more than 1 mm.*

**Table 17 – Pull force on pins**

Ratings of the equivalent plug type	Number of poles	Pull force N
Up to and including 10 A 130/250 V	2	40
	3	50
Over 10 A up to and including 16 A 130/250 V	2	50
	3	54
Over 10 A up to and including 16 A 440 V	3	54
	More than 3	70

*For the purpose of this test, protective earthing contacts, irrespective of their number, are considered as one pole.*

*Tests b) and c) are made separately, each with new samples.*

## **16 External flexible cords**

**16.1** MAINS supply flexible cords shall be of the sheathed type and comply with the following as appropriate:

- if rubber sheathed, comply with IEC 60245;
- if PVC sheathed, comply with the IEC 60227 series.

Other types of cords can be used if they have equivalent or better electro-mechanical and fire safety properties as above.

NOTE 1 Where national or regional standards exist, they can be used to show compliance with the above paragraph.

*Compliance is checked by testing MAINS supply flexible cords in accordance with IEC 60227 or IEC 60245.*

NOTE 2 In Australia and New Zealand special national conditions apply for external flexible cords.

Non-detachable flexible cables and cords of CLASS I apparatus shall be provided with a green/yellow core connected to the PROTECTIVE EARTHING TERMINAL of the apparatus and, if a plug is provided, to the protective earthing contact of the plug.

*Compliance is checked by inspection.*

**16.2** Power supply cord conductors shall have a nominal cross-sectional area not less than those shown in Table 18.

**Table 18 – Nominal cross-sectional areas of external flexible cords**

<b>RATED CURRENT CONSUMPTION of the apparatus<sup>a</sup></b> A	<b>Nominal cross-sectional area</b> mm <sup>2</sup>
Up to and including 3	0,5 <sup>b</sup>
Over 3 up to and including 6	0,75
Over 6 up to and including 10	1
Over 10 up to and including 16	1,5
<sup>a</sup> The RATED CURRENT CONSUMPTION includes currents which can be drawn from the socket-outlets providing MAINS power for other apparatus. <sup>b</sup> This nominal cross-sectional area is allowed only for CLASS II apparatus and provided that the length of the supply cord, measured between the point where the cord or the cord guard enters the apparatus, and the entry to the plug, does not exceed 2 m.	

For higher currents, reference is made to IEC 60950-1:2005, Table 3B.

*Compliance is checked by measurement.*

NOTE In the USA and Canada, a minimum cross-sectional area of 0,81 mm<sup>2</sup> is required.

**16.3** Flexible cords, not complying with 16.1, used as a connection between the apparatus and other apparatus used in combination with it, and comprising HAZARDOUS LIVE conductors, shall comply with a) and b):

- a) Have adequate dielectric strength.

Compliance is checked by applying the dielectric strength test using a sample of approximately 1 m length and by applying the relevant test voltage according to 10.4.2 for the grade of insulation under consideration, as follows:

- for insulation of a conductor: by testing the individual conductor insulation;
- for SUPPLEMENTARY INSULATION, for example sleeving around a group of conductors: between a conductor inserted into the sleeve and metal foil wrapped tightly round the sleeve for a length of at least 100 mm.

NOTE Where a power supply cord, whose insulating properties comply with those of the cord types of 16.1, is used inside the apparatus, either as an extension of the external power supply cord or as an independent cable, its sheath is considered to be adequate SUPPLEMENTARY INSULATION.

b) Withstand bending and other mechanical stresses occurring during intended use.

Compliance is checked by the test of 3.1 of IEC 60227-2:1997, except that Table 19 of this standard applies.

**Table 19 – Mass and pulley diameter for stress test**

Overall diameter of the flexible cable or cord mm	Mass kg	Pulley diameter mm
Up to and including 6	1,0	60
Over 6 up to and including 12	1,5	120
Over 12 up to and including 20	2,0	180

The carrier moves to and fro 15 000 times (30 000 movements).

The voltage  $U$  between the conductors is the test voltage according to 10.4.

During and after the test, the specimen shall withstand the dielectric strength test specified in 10.4.

**16.4** Conductors of flexible cords used as a connection between the apparatus and other apparatus used in combination with it shall have a cross-sectional area such that the temperature rise of the insulation under normal operating conditions and under fault conditions is negligible.

Compliance is checked by inspection. In case of doubt, the temperature rises of the insulation are determined under normal operating conditions and under fault conditions. The temperature rises shall not exceed the values given in the appropriate columns of Table 3.

**16.5** The apparatus shall allow the external flexible cords, comprising one or more HAZARDOUS LIVE conductors, to be so connected that the connecting points of the conductors are relieved from strain, that the outer covering is protected from abrasion, and that the conductors are prevented from twisting.

Moreover, it shall not be possible to push an external cord back into the apparatus through its aperture if this can impair safety in the sense of this standard.

The method by which the relief from strain and the prevention of twisting is provided shall be clearly seen.

Makeshift methods, such as tying the cord into a knot or tying the cord with a string, are not permitted.

The devices for strain and twist relief shall either be made of insulating material, or have a fixed covering of insulating material other than natural rubber, if an insulation fault of the cord may make ACCESSIBLE conductive parts HAZARDOUS LIVE.

For CLASS I apparatus, the arrangement of the TERMINALS for the MAINS supply flexible cord, or the length of the conductors between the device for strain and twist relief and the TERMINALS, shall be such that the HAZARDOUS LIVE conductors become taut before the conductor connected to the PROTECTIVE EARTHING TERMINAL, in case the cord slips out of the device for strain and twist relief.

*Compliance is checked by inspection and by the following test.*

*The test is made with the type of flexible cord attached to the apparatus.*

*The apparatus is fitted with its flexible cord, the device for strain and twist relief being appropriately used. The conductors are introduced into the TERMINALS, and the TERMINAL screws, if any, are slightly tightened, so that the conductors cannot easily change their position.*

*After this preparation, pushing the cord further into the apparatus shall not be possible or shall cause no hazard in the sense of this standard.*

*A mark is made on the cord, under strain, near the aperture, and the flexible cord is subjected 100 times to a pull of 40 N for a duration of 1 s each. The pull shall not be applied in jerks.*

*Immediately afterwards, the cord is subjected for a period of 1 min to a torque of 0,25 Nm.*

*During the test, the cord shall not be displaced by more than 2 mm, the measurement being made while the cord is still under strain. The ends of the conductors shall not be noticeably displaced in the TERMINALS and no damage to the flexible cord shall be caused by the device for strain and twist relief.*

**16.6** Apertures for external flexible cords mentioned in 16.5 shall be so constructed that there is no risk of damage to the cord during its introduction or subsequent movement.

NOTE This can be done, for example, by rounding the edges of the aperture or by using an appropriate bushing of insulating material.

*Compliance is checked by inspection and by fitting flexible cords.*

**16.7** TRANSPORTABLE APPARATUS shall have an appliance inlet according to IEC 60320-1 for connection to the MAINS by detachable cord sets or shall have a means of stowage to protect the MAINS cord when not in use, for example a compartment, hooks or pegs.

*Compliance is checked by inspection.*

## **17 Electrical connections and mechanical fixings**

**17.1** Screw TERMINALS providing electrical contact and screw fixings which during the life of the apparatus will be loosened and tightened several times shall have adequate strength.

Screws exerting contact pressure and screws with a nominal diameter less than 3 mm which form part of the above-mentioned screw fixings shall screw into a metal nut or a metal insert.

However, screws having a nominal diameter less than 3 mm, which do not exert contact pressure, need not be screwed into metal, provided that the screw fixing withstands the torque specified in Table 20 for screws of 3 mm diameter.

Screw fixings which during the life of the apparatus will be loosened and tightened several times include TERMINAL screws, screws for fixing covers (as far as they must be loosened to open the apparatus), screws for fixing handles, knobs, legs, stands and the like.

Compliance is checked by the following test.

The screws are loosened and then tightened, with a torque according to Table 20:

- 5 times in the case of screws operating in a thread of metal;
- 10 times in the case of screws operating in wood, WOOD-BASED MATERIAL or in a thread in insulating material.

In the latter case, the screws are to be completely removed and reinserted each time.

The screws shall not be tightened in jerks.

After the test, there shall be no deterioration impairing safety in the sense of this standard.

The material in which the screws are inserted is verified by inspection.

**Table 20 – Torque to be applied to screws**

Nominal diameter of screw mm	Torque Nm		
	I	II	III
Up to and including 2,8	0,2	0,4	0,4
Over 2,8 up to and including 3,0	0,25	0,5	0,5
Over 3,0 up to and including 3,2	0,3	0,6	0,6
Over 3,2 up to and including 3,6	0,4	0,8	0,6
Over 3,6 up to and including 4,1	0,7	1,2	0,6
Over 4,1 up to and including 4,7	0,8	1,8	0,9
Over 4,7 up to and including 5,3	0,8	2,0	1,0
Over 5,3 up to and including 6,0	–	2,5	1,25

The test is made by means of a suitable test screwdriver, spanner or key, applying a torque as shown in Table 20, the appropriate column being

- for metal screws without heads, if the screw, when tightened, does not protrude from the hole: **I**
- for other metal screws and for nuts: **II**
- for screws of insulating material:
  - having a hexagonal head with the dimension across flats exceeding the overall thread diameter, or
  - with a cylindrical head and a socket for a key, the socket having a dimension across flats not less than 0,83 times the overall thread diameter, or
  - with a head having a slot or cross slots, the length of which exceeds 1,5 times the overall thread diameter: **II**
- for other screws of insulating material: **III**

**17.2** Means shall be provided to ensure the correct introduction of screws into female threads in non-metallic material, if they will be loosened and tightened several times during the life of the apparatus and contribute to safety in the sense of this standard.

*Compliance is checked by inspection and by manual test.*

*This requirement is considered to be met if introduction in a slanting manner is prevented, for example by guiding the screw in the part to be fixed by a recess in the nut or a lead to the screw.*

**17.3** Screws or other fixing devices intended to fix covers, legs, stands or the like, shall be captive in order to prevent replacement during servicing by screws or other fixing devices, which might cause a reduction of CLEARANCES or CREEPAGE DISTANCES between ACCESSIBLE conductive parts or parts connected to them and HAZARDOUS LIVE parts below the values given in Clause 13.

Such screws need not be captive if, when replaced by screws having the same nominal diameter, pitch and sharpness with a length of 10 times their nominal diameter, using the torque of Table 20, the distances are not less than those stated in Clause 13.

*Compliance is checked by inspection and measurement.*

**17.4** Conductive parts permanently fixed together and carrying a current exceeding 0,2 A across their interface under normal operating conditions shall be secured in such a way that loosening is prevented.

*Compliance is checked by inspection and by manual test.*

NOTE 1 Sealing by compound or the like provides satisfactory locking only for screw connections not subject to torsion.

NOTE 2 If the fixing consists of more than one screw or rivet, only one of them need be locked.

NOTE 3 For rivets, a non-circular shank or an appropriate notch can be a sufficient guard against rotation.

**17.5** Electrical connections in circuits carrying a current exceeding 0,2 A under normal operation conditions shall be so designed that contact pressure is not transmitted through insulating material other than ceramic, unless there is sufficient resiliency in the metallic parts to compensate for any possible shrinkage of the insulating material.

*Compliance is checked by inspection.*

**17.6** Stranded conductors of flexible supply cords carrying a current exceeding 0,2 A under normal operating conditions, which are connected to screw TERMINALS, shall not be consolidated by lead-tin soldering where they are subject to contact pressure, unless the clamping means is so designed that there is no risk of a bad contact due to cold flow of the solder.

*Compliance is checked by inspection.*

**17.7** Cover-fixing devices, which may be operated during the life of the apparatus, shall have adequate mechanical strength, if the failure of such devices would impair safety in the sense of this standard.

The locked and unlocked positions of these devices shall not be ambiguous, and it shall not be possible to unlock the devices inadvertently.

*Compliance is checked by inspection, by operating the device and by one of the following tests:*

- *In the case of devices the operation of which is effected by a combination of rotary and linear movements, the device is locked and unlocked and the torques or forces necessary for this operation are measured. While the device is in the locked position, a torque or force of twice the value necessary to lock the device, with a minimum of 1 Nm or 10 N is applied in the locking direction, unless it is unlocked by a smaller torque or force in the same direction.*

*This operation is performed 10 times.*

*The torque or force necessary to unlock the device shall be at least 0,1 Nm or 1 N.*

- *In the case of covers fixed by means of snap fasteners, the cover is removed and replaced 10 times in the intended way.*

*After this test the cover shall still comply with the tests by means of the rigid test finger and the test hook described in 9.1.7 a) and b).*

**17.8** Detachable legs or stands supplied by the manufacturer of the apparatus shall be delivered with the relevant fixing means.

*Compliance is checked by inspection.*

**17.9** Internal pluggable connections shall be so designed that unintended loosening is unlikely, if the loosening can impair the safety in the sense of this standard.

*Compliance is checked by inspection and in case of doubt by applying a pull of 2 N in any direction to the connection.*

NOTE For other internal connections, see 8.11.

## **18 Mechanical strength of picture tubes and protection against the effects of implosion**

### **18.1 General**

Picture tubes with a maximum face dimension exceeding 16 cm either shall be intrinsically protected with respect to effects of implosion and to mechanical impact, or the enclosure of the apparatus shall provide adequate protection against the effects of an implosion of the tube.

A protective film, attached to the faceplate of the picture tube as part of the implosion protection system, shall be covered on all edges by the enclosure of the apparatus.

A non-intrinsically protected picture tube shall be provided with an effective protective screen, which cannot be removed BY HAND. If a separate screen of glass is used, it shall not be in contact with the surface of the tube.

*Compliance is checked by inspection, by measurement, and by the tests of:*

- *IEC 61965 for intrinsically protected tubes, including those having integral protective screens;*
- *18.2 for apparatus having non-intrinsically protected tubes.*

NOTE 1 A picture tube is considered to be intrinsically protected with respect to the effects of implosion if, when it is correctly mounted, no additional protection is necessary.

NOTE 2 To facilitate the tests, the tube manufacturer is requested to indicate the most vulnerable area on the tubes to be tested.

## **18.2 Non-intrinsically protected picture tubes**

*The apparatus, with the picture tube and the protective screen in position, is placed on a horizontal support at a height of  $(75 \pm 5)$  cm above the floor, or directly on the floor if the apparatus is obviously intended to be positioned on the floor.*

*The tube is made to implode inside the enclosure of the apparatus by the following method.*

*Cracks are propagated in the envelope of each tube as described below.*

*An area on the side or on the face of the tube is scratched (see Figure 12) with a diamond stylus and this place is repeatedly cooled with liquid nitrogen or the like until a fracture occurs. To prevent the cooling liquid from flowing away from the test area, a dam of modelling clay or the like should be used.*

*After this test, no particles having a mass exceeding 2 g shall have passed a 25 cm high barrier, placed on the floor, 50 cm from the projection of the front of the apparatus, and no particle shall have passed a similar barrier at 2 m.*

## **19 Stability and mechanical hazards**

### **19.1 Stability requirements**

Apparatus having a mass of 7 kg or more shall have adequate stability. In addition, the stability shall be ensured when legs, carts or stands supplied or recommended by the manufacturer are fitted.

*Compliance is checked by the tests of 19.2, 19.3 and 19.4.*

Apparatus required to be fastened in place to meet the stability requirements and consequently provided with the warning of 5.5.2 f) is not required to be subjected to these tests. Apparatus expected to be installed by a USER and having a screw hole or other means to secure the apparatus, such as for securement to a table or for earth quake protection, is not considered to be fastened in place.

The test of 19.4 applies only to:

- apparatus with a mass of 25 kg or more, or
- apparatus, excluding loudspeaker systems, with a height of 1 m or more, or
- apparatus, excluding loudspeaker systems, in combination with a supplied or recommended cart or stand with a total height of 1 m or more.

*During the tests, the apparatus shall not overturn.*

### **19.2 Test at 10° to the horizontal**

*The apparatus, or apparatus in combination with a supplied or recommended cart or stand, is placed in its intended position of use on a plane, inclined at an angle of 10° to the horizontal, and then rotated slowly through an angle of 360° about its normal vertical axis.*

*All doors, drawers, casters, adjustable feet and other appurtenances are arranged in any combination that results in the least stability. The apparatus, or apparatus in combination with a supplied or recommended cart or stand, shall be blocked, if necessary, by means of a stop of the smallest dimensions possible, to keep it from sliding or rolling.*

*If, however, the apparatus, or apparatus in combination with a supplied or recommended cart or stand, is such that, were it to be tilted through an angle of 10° when standing on a horizontal*

*plane, a part of it not normally in contact with the supporting surface would touch the horizontal plane, the apparatus is placed on a horizontal support and the combination is tilted in the most unfavourable direction through an angle of 10°.*

NOTE The test on the horizontal support can be necessary, for example, for apparatus provided with small feet, casters or the like.

### **19.3 Vertical force test**

*The apparatus or apparatus in combination with a supplied or recommended cart or stand is placed on a non-skid surface that is at an angle not exceeding 1° to the horizontal with lids, flaps, drawers, doors, casters, wheels, adjustable feet and other appurtenances in the most unfavourable position.*

*A force of 100 N directed vertically downwards is applied in such a way as to produce the maximum overturning moment, to any point of any horizontal surface, protrusion or recess, provided that the distance from that point to the non-skid surface does not exceed 75 cm. The apparatus shall not overturn during the test. If, during the test, the supporting surface prevents the apparatus from overturning, the test shall be repeated such that the supporting surface is not used to pass the test.*

### **19.4 Horizontal force test**

*The apparatus or apparatus in combination with a supplied or recommended cart or stand is placed on a horizontal non-skid surface. All doors, drawers, casters, adjustable feet and other moveable parts are arranged in any combination that results in the least stability.*

*The apparatus or apparatus in combination with a supplied or recommended cart or stand shall be blocked, if necessary, by means of a stop of the smallest dimensions possible, to keep it from sliding or rolling.*

*An externally applied horizontal force of 13 % of the weight of the apparatus or 100 N, whichever is less, is applied in a horizontal direction to that point on the apparatus that will result in the least stability. The force shall not be applied more than 1,5 m above floor level.*

*If the apparatus or apparatus in combination with a supplied or recommended cart or stand becomes unstable, it shall not overturn at a tilt of less than 15° from the vertical.*

### **19.5 Test of edges and corners**

Edges or corners, except those required for proper apparatus functioning, shall be smoothed (no abrupt discontinuity) when they could otherwise be hazardous to the USER because of location or application in the apparatus.

*Compliance is checked by inspection.*

### **19.6 Mechanical strength of glass**

#### **19.6.1 Requirements**

Glass, with the exception of picture tubes and laminated glass, with a surface area exceeding 0,1 m<sup>2</sup> or with a major dimension exceeding 450 mm, shall not be shattered in a manner likely to result in a skin-lacerating injury.

*Compliance is checked by the test of 12.1.4 using the impact hammer only.*

*During and after the test, glass shall:*

- *not break or crack; or*

- *not expel pieces of glass greater than 30 g in mass or greater than 50 mm in any dimension; or*
- *pass the fragmentation test of 19.6.2 on a separate test sample.*

### **19.6.2 Fragmentation test**

*The test sample is supported over its whole area and precautions shall be taken to ensure that particles will not be scattered upon fragmentation. Then the test sample is shattered with a centre punch placed approximately 15 mm in from the midpoint of one of the longer edges of the test sample. Within 5 min of fracture, and without using any aid to vision, except spectacles if normally worn, the particles are counted in a square of 50 mm side located approximately at the centre of the area of coarsest fracture and excluding any area within 15 mm of any edge or hole.*

*The test sample shall fragment in such a way that the number of particles counted in a square of 50 mm side shall not be less than 45. If the construction is such that the particles are kept together (no loose particles in the square), the sample is considered to comply with the requirements.*

NOTE A suitable method of counting the particles is to place a square of 50 mm side of transparent material over the test sample and mark a spot of ink as each particle within the square is counted. To count particles at the edges of the square, select any two adjacent sides of the square and count all the particles intersected by these, and exclude all other intersected particles.

## **19.7 Wall or ceiling mounting means**

### **19.7.1 Requirements**

For apparatus with wall or ceiling mounting means:

- If the manufacturer specifies a specific wall or ceiling mount, the combination of the mount and the apparatus shall comply with 19.7.2, Test 1. The hardware used to fix the mounting means to the equipment shall either be provided with the apparatus, or described in detail in the user instructions (for example, length of screws, diameter of the screws, etc.).
- If the manufacturer does not specify a specific wall or ceiling mount, but the apparatus is provided with any part (for example a hook or threaded hole) which facilitates attaching a mount to the apparatus, such part shall comply with 19.7.2, Test 2, as appropriate. The user instruction shall advise on the safe use of such parts (for example, screw size including thread size and length, number of screws, etc.).
- If the apparatus is provided with threaded parts for attachment of the mounting means, the threaded parts without the mounting means shall additionally comply with 19.7.2, Test 3.

NOTE The tests are meant to test the fixing of the mounting means to the equipment and not to test the fixing to the wall or ceiling.

### **19.7.2 Test methods**

*If the construction involves plastic materials, the tests shall be performed after the stress relief test of 12.1.6.*

#### **Test 1**

*The apparatus is mounted in accordance with the manufacturer's instructions and the mounting means positioned, when possible, to represent the most severe stress on the supports.*

*A force in addition to the weight of the apparatus is applied downwards through the centre of gravity of the apparatus, for 1 min. The additional force shall be:*

- *three times the weight of the apparatus, or*
- *the weight of the apparatus plus 880 N,*

whichever is less.

In addition, for wall mounted apparatus, a horizontal force of 50 N is applied laterally for 60 s.

## Test 2

The test force shall be equivalent to the least of the following divided by the number of attachment points in the mounting system:

- four times the weight of the apparatus, or
- two times the weight of the apparatus plus 880 N.

Each point in the mounting system shall be subjected to a shear force perpendicular to its centre axis for 1 min. The force shall be applied in four directions, one direction at a time, separated by 90°.

Each point in the mounting system, one at a time, shall be subjected to an inward directed push force parallel to its centre axis for 1 min.

Each point in the mounting system, one at a time, shall be subjected to an outward directed pull force parallel to its centre axis for 1 min.

## Test 3

A torque according to column II of Table 20 shall be applied to each threaded part, one at a time. If a corresponding screw fastener is supplied by the manufacturer, it shall be used for the test. If no corresponding screw fastener is supplied by the manufacturer, even though a screw type may be recommended in the user instructions, any screw with the same diameter shall be used for the test.

### 19.7.3 Compliance

Compliance is checked by inspection and by the tests of 19.7.2, as applicable. The apparatus, its associated mounting means or the threaded parts shall not become dislodged and shall remain mechanically intact and secure during the test.

## 20 Resistance to fire

### 20.1 Requirements

The apparatus shall be so designed that the start and spread of fire is prevented as far as possible, and shall not give rise to danger of fire to the surroundings of the apparatus.

This is achieved as follows:

- by using good engineering practice in design and production of the apparatus to prevent the formation of POTENTIAL IGNITION SOURCES; and
- by using materials of low flammability for internal parts within the specified distances of POTENTIAL IGNITION SOURCES (see Table 21); and
- by using FIRE ENCLOSURES and/or barriers to limit the spread of fire.

The requirements are considered to be fulfilled if the apparatus complies with the requirements of 20.2 and 20.3.

NOTE In Australia and New Zealand, special national conditions apply which include tests based on reconciliation with the philosophy of the IEC 60695 series with respect to glow-wire testing, needle-flame testing, consequential testing and end-product consequential testing.

## **20.2 Electrical components and mechanical parts**

### **20.2.1 General**

Electrical components and mechanical parts, with the exception of those in a) and b), shall comply with the requirements of 20.2.2, 20.2.3, 20.2.4 and 20.2.5.

- a) Components that are contained in an enclosure having a flammability category of V-0 according to IEC 60695-11-10 and having openings only for the connecting wires filling the openings completely, and for ventilation not exceeding 1 mm in width regardless of length.
- b) The following parts, which would contribute negligible fuel to a fire:
  - small mechanical parts, such as mounting parts, gears, cams, belts and bearings, if the mass of the non-metallic material of each part does not exceed 4 g, excluding metal, glass and ceramic; and
  - small electrical components, such as:
    - integrated circuits, transistors, optocoupler packages;
    - capacitors with a volume not exceeding 1 750 mm<sup>3</sup>,provided these components are mounted on material of flammability category V-1 or better according to IEC 60695-11-10.

NOTE 1 Connectors are regarded as electrical components.

NOTE 2 In considering how to minimise propagation of fire and what "small parts" are, the cumulative effect of small parts adjacent to each other can be important to determine the possible effect of propagating fire from one part to another.

### **20.2.2 Electrical components**

Electrical components shall comply with the relevant flammability requirement of Clause 14.

Where there are no applicable flammability requirements in Clause 14, the requirements of 20.2.5 apply.

*Compliance is checked by appropriate tests of Clause 14 or 20.2.5*

### **20.2.3 Internal wiring**

Insulation on wiring shall not contribute to the spread of fire under following conditions:

- a) wiring working at voltages exceeding 4 kV (peak) a.c. or d.c., or
- b) wiring leaving an internal FIRE ENCLOSURE with the exception of insulation consisting of PVC, TFE, PTFE, FEP or neoprene,
- c) wiring within the areas mentioned in Table 21, unless they are shielded by a barrier according to Table 21, with the exception of insulation consisting of PVC, TFE, PTFE, FEP or neoprene.

NOTE Reference is made to ISO 1043-1 for the meaning of the abbreviations.

*Compliance is checked by the tests of Clause G.2.*

### **20.2.4 PRINTED BOARDS**

Base material of PRINTED BOARDS, on which the AVAILABLE POWER at a connection exceeds 15 W operating at a voltage exceeding 50 V up to and including 400 V (peak) a.c. or d.c. under normal operating conditions, shall be of flammability category V-1 or better according to IEC 60695-11-10 or VTM-1 or better according to ISO 9773, unless the PRINTED BOARDS are protected by an enclosure meeting the flammability category V-0 according to IEC 60695-11-10 or VTM-0 according to ISO 9773, or be made of metal, having openings only for connecting wires which fill the openings completely.

Base material of PRINTED BOARDS, on which the AVAILABLE POWER at a connection exceeds 15 W operating at a voltage exceeding 400 V (peak) a.c. or d.c. under normal operating conditions, and base material of PRINTED BOARDS supporting spark gaps which provide protection against overvoltages, shall be of flammability category V-0 according to IEC 60695-11-10 or VTM-0 according to ISO 9773, unless the PRINTED BOARDS are contained in a metal enclosure, having openings only for connecting wires which fill the openings completely.

*Compliance is checked for the smallest thickness of PRINTED BOARD used, in accordance with either:*

- a) IEC 60695-11-10 or ISO 9773; or
- b) with Clause G.1 on specimens of boards as used in the apparatus, but without components.

*The tests under b) are performed after a preconditioning of 24 h at a temperature of  $(125 \pm 2)$  °C in an air-circulating oven and a subsequent cooling period of 4 h at room temperature in a desiccator over anhydrous calcium chloride.*

#### **20.2.5 Components and parts not covered by 20.2.2, 20.2.3 and 20.2.4**

Subclause 20.2.5 does not apply to FIRE ENCLOSURES.

When the distance between POTENTIAL IGNITION SOURCES and components or parts mentioned in the heading does not exceed the values specified in Table 21, these components and parts shall comply with the relevant flammability category according to IEC 60695-11-10 as specified in Table 21, unless shielded from POTENTIAL IGNITION SOURCES by a barrier made of metal or meeting the flammability category as specified in Table 21.

No PASSIVE FLAMMABILITY requirements apply to components and parts shielded by the barrier unless required elsewhere in this standard. The barrier shall be solid and rigid and shall have dimensions covering at least the areas specified in Table 21 and shown in Figure 13. The dimensions of a non-metallic barrier shall be sufficient to prevent ignition of its edges and of the edges of openings in the barrier.

*Compliance is checked by inspection, measurement and by the test of Clause G.3.*

PRINTED BOARDS carrying POTENTIAL IGNITION SOURCES are not considered to be a barrier for the purpose of Clause 20.

POTENTIAL IGNITION SOURCES inside electrical components are not included in 20.2.5.

**Table 21 – Distances from POTENTIAL IGNITION SOURCES and consequential flammability categories**

Open-circuit voltage of the POTENTIAL IGNITION SOURCE	For apparatus containing voltages not exceeding 4 kV				For apparatus containing voltages exceeding 4 kV			
	Minimum distance from POTENTIAL IGNITION SOURCES to the components or parts  (see Figure 13)		Flammability category of components and parts according to IEC 60695-11-10, if the distance is less than the minimum distance required in the previous column	Minimum distance from POTENTIAL IGNITION SOURCE to non-metallic barrier  Barrier flammability category, if other than metal	Minimum distance from POTENTIAL IGNITION SOURCES to the components or parts  (see Figure 13)		Flammability category of components and parts according to IEC 60695-11-10, if the distance is less than the minimum distance required in the previous column	Minimum distance from POTENTIAL IGNITION SOURCE to non-metallic barrier.  Barrier flammability category, if other than metal
	Down-wards or side-ways	Up-wards			Down-wards or side-ways	Up-wards		
V (peak) a.c. or d.c.								
> 50 up to and including 400	13 mm	50 mm	HB75	No requirement	13 mm	50 mm	V-1	5 mm V-1
> 400 up to and including 4 000	13 mm	50 mm	V-1	5 mm V-1	20 mm	50 mm	V-1	5 mm V-0
> 4 000					See 20.3			

Wood and WOOD-BASED MATERIAL with a thickness of at least 6 mm is considered to fulfil the V-1 requirement of Clause 20.

For apparatus containing voltages exceeding 4 kV under normal operating conditions and where protection is based on distances exceeding those as specified in Table 21, the material of the outer enclosure shall comply with the flammability category HB40 or better according to IEC 60695-11-10. However, no flammability requirements apply to those parts or areas of the outer enclosure of the apparatus which are protected by barriers or internal FIRE ENCLOSURES.

*Compliance is checked for the smallest thickness used in accordance with IEC 60695-11-10 or Clause G.1.*

### 20.3 FIRE ENCLOSURE

**20.3.1** POTENTIAL IGNITION SOURCES with open-circuit voltages exceeding 4 kV (peak) a.c. or d.c. under normal operating conditions shall be contained in a FIRE ENCLOSURE which shall comply with the flammability category V-1 or better according to IEC 60695-11-10.

A FIRE ENCLOSURE is not required if:

- the open-circuit voltage of the POTENTIAL IGNITION SOURCE is limited to a value < 4 kV by means of an electronic protective circuit, or
- the open-circuit voltage of the POTENTIAL IGNITION SOURCE does not exceed 4 kV at the moment the faulty connection or interruption occurs.

The voltage is measured with the smallest distance across a faulty connection or interruption by which arcing could start.

Wood and WOOD-BASED MATERIAL with a thickness of at least 6 mm is considered to fulfil the V-1 requirement of Clause 20

Compliance is checked for the smallest thickness used in accordance with IEC 60695-11-10 or Clause G.1.

**20.3.2** Internal FIRE ENCLOSURES shall not have openings for ventilation exceeding 1 mm in width regardless of length.

Openings for connecting wires shall be filled completely by the wires.

Compliance is checked by inspection and measurement.

**20.3.3** If the requirements of 20.3.1 and 20.3.2 are met by an internal FIRE ENCLOSURE no flammability requirements apply to the outer enclosure of the apparatus and no PASSIVE FLAMMABILITY requirements apply to components or parts outside the internal FIRE ENCLOSURE, unless required elsewhere in the standard.

Insulation of internal wiring complying with 20.2.3 is considered to constitute part of an internal FIRE ENCLOSURE.

Compliance is checked by inspection.

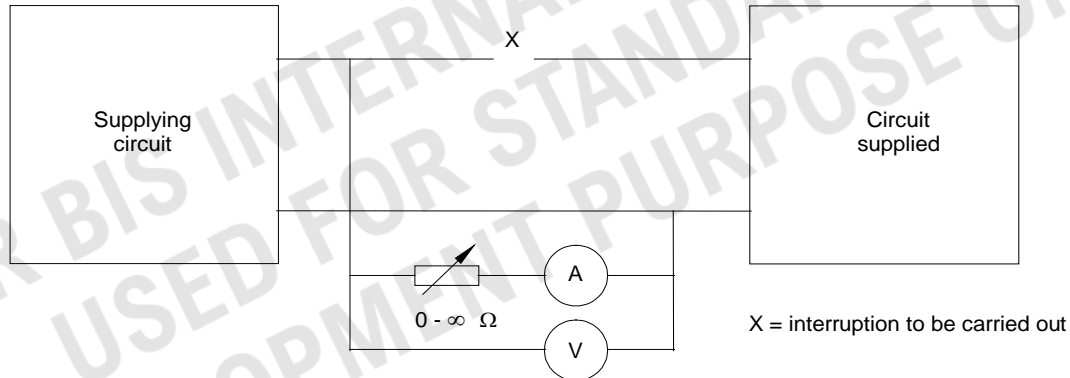

NOTE See 4.3.

**Figure 1 – Test circuit for fault conditions**

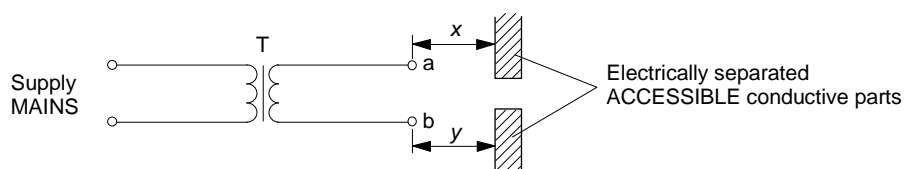

The diagram shows a SEPARATING TRANSFORMER T, where point a is HAZARDOUS LIVE relative to point b. If a and b are inside the apparatus, the sum of the distances x and y is taken into account for the purpose of checking compliance with 8.6.

NOTE See 8.6.

**Figure 2 – Example of an assessment of REINFORCED INSULATION**

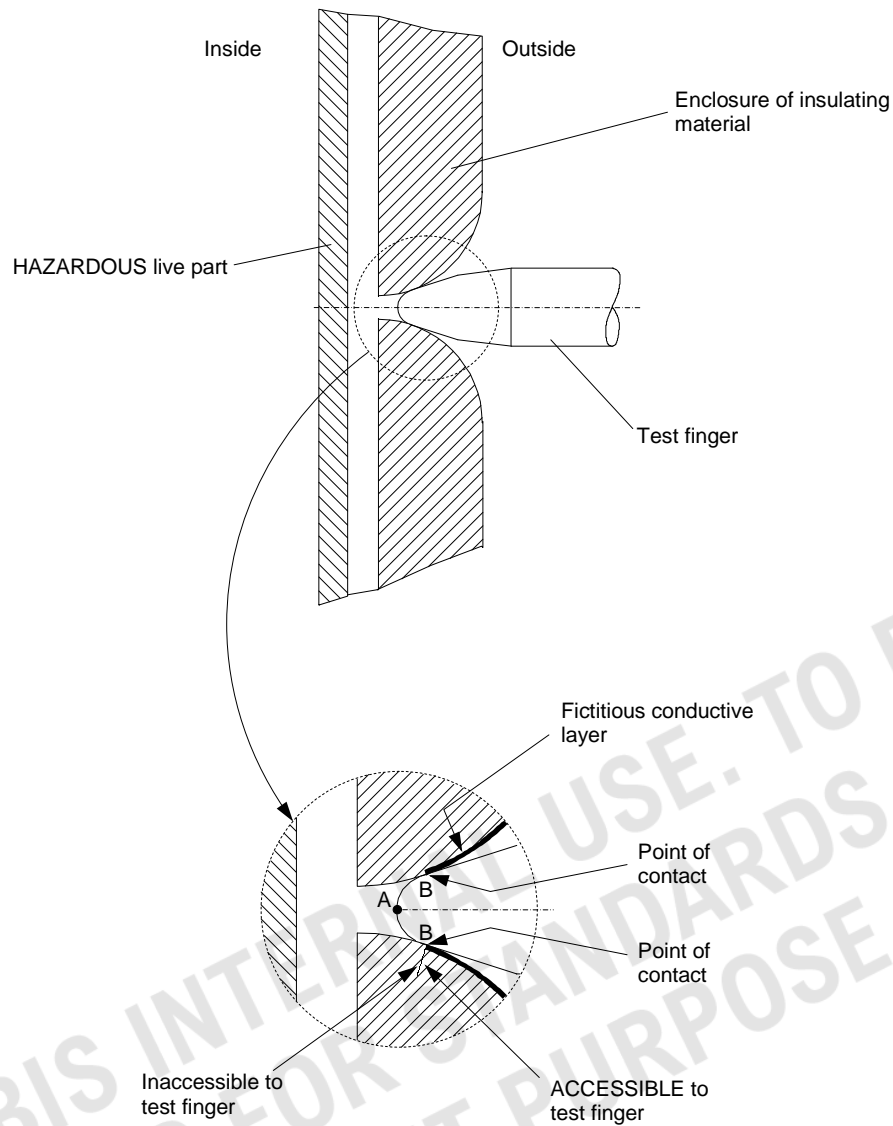

Point A is used for determining accessibility (see 9.1.1.3)

Point B is used for measurements of CLEARANCES and CREEPAGE DISTANCES (see Clause 13)

NOTE See 9.1.1.3 and 13.3.1.

**Figure 3 – Example of ACCESSIBLE parts**

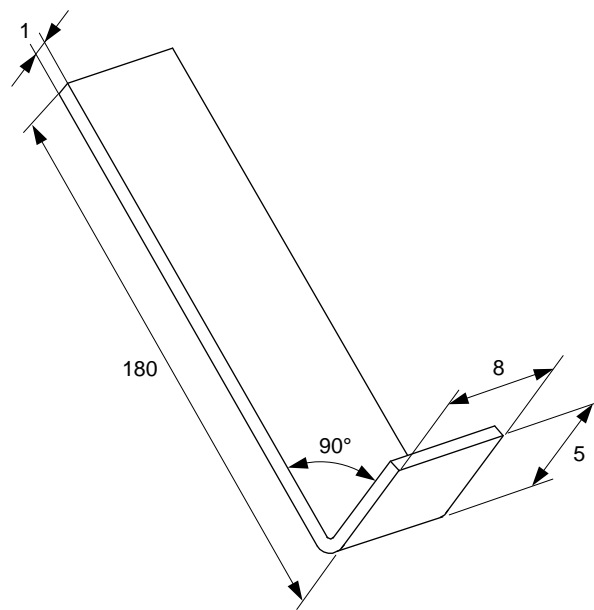

NOTE See 9.1.7.

Dimensions in millimetres

Figure 4 – Test hook

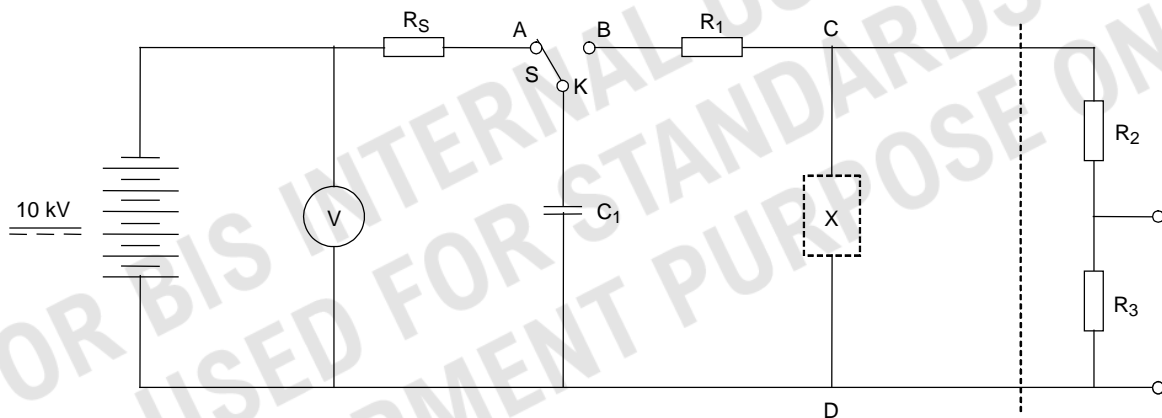

$$C_1 = 1 \text{ nF} \quad R_1 = 1 \text{ k}\Omega \quad R_2 = 100 \text{ M}\Omega \quad R_3 = 0,1 \text{ M}\Omega \quad R_s = 15 \text{ M}\Omega$$

The switch S is a critical part of the circuit. It shall be so designed that as little as possible of the available energy is dissipated in arcing or inadequate insulation. An example of such a switch is given in Figure 5b.

The component X under test is connected to the terminals C and D. Optionally the voltage divider  $R_2$ ,  $R_3$  may be provided so that an oscilloscope connected across  $R_3$  permits the observation of the voltage waveform across the component under test. This voltage divider is compensated so that the observed waveform corresponds with that across the component under test.

NOTE See 10.2 and 14.2.

Figure 5a – Surge test – Test circuit

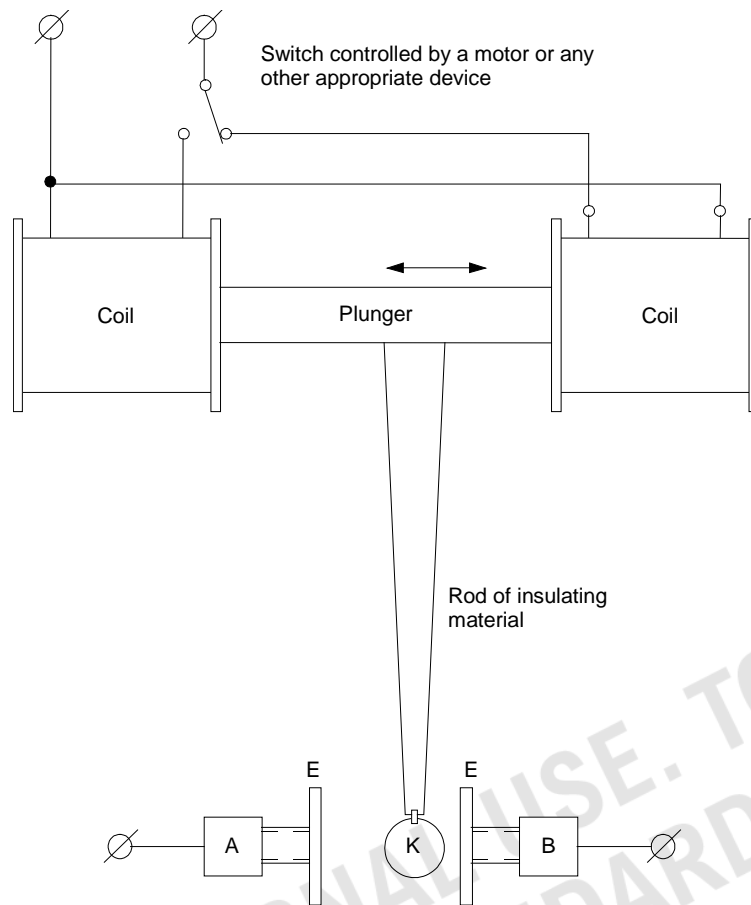

The switch (S in Figure 5a) comprises the following parts:

- the brass pillars A and B support circular electrodes E spaced at a distance of 15 mm;
- K is a brass sphere of 7 mm diameter and is supported on a rigid rod of insulating material approximately 150 mm long.

A, B and K are connected as shown in Figure 5a, K by means of a flexible wire.

Care shall be taken to avoid bouncing of sphere K.

Figure 5b – Surge test – Example of a switch to be used in the test circuit

Figure 5 – Surge test

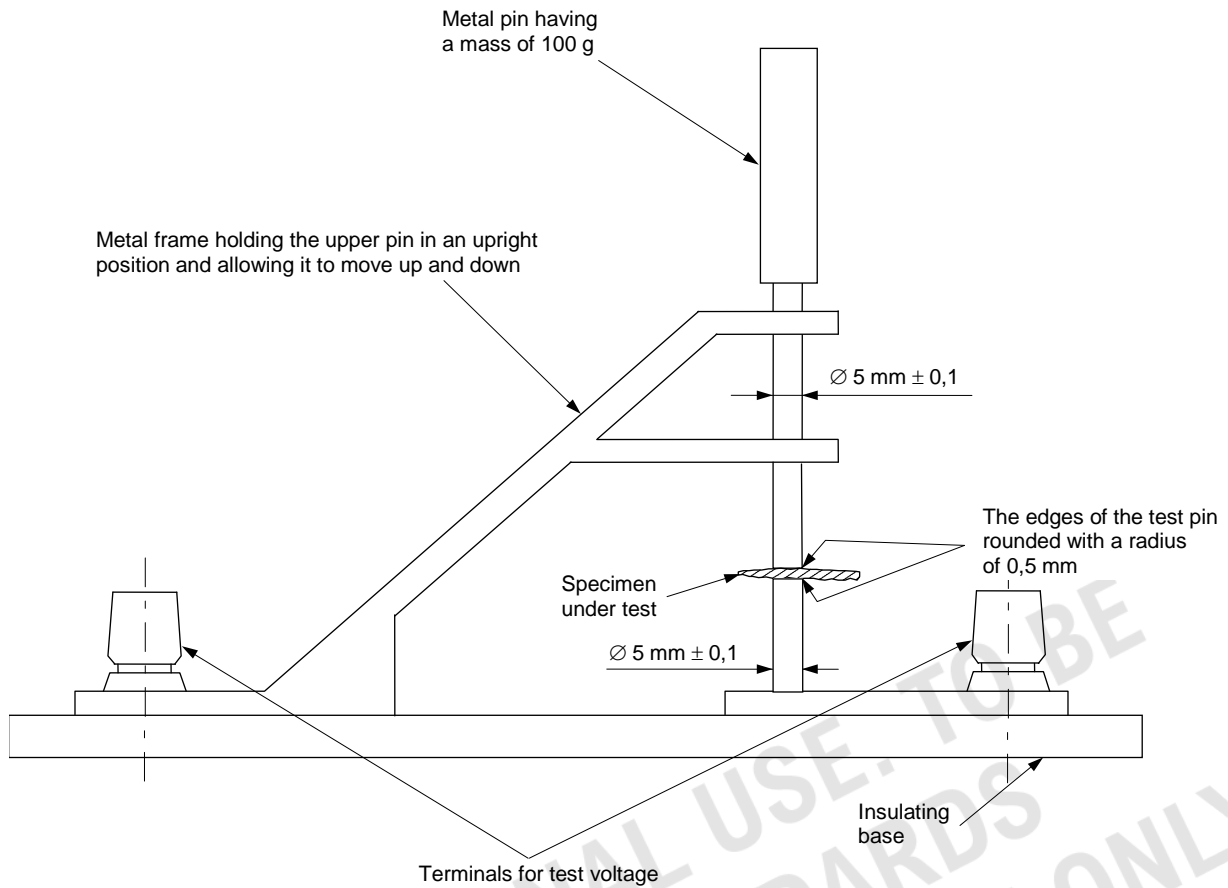

NOTE See 10.4.2.

Figure 6 – Dielectric strength test instrument

FOR BIS INTERNAL USE. TO BE  
USED FOR STANDARDS  
DEVELOPMENT PURPOSE ONLY

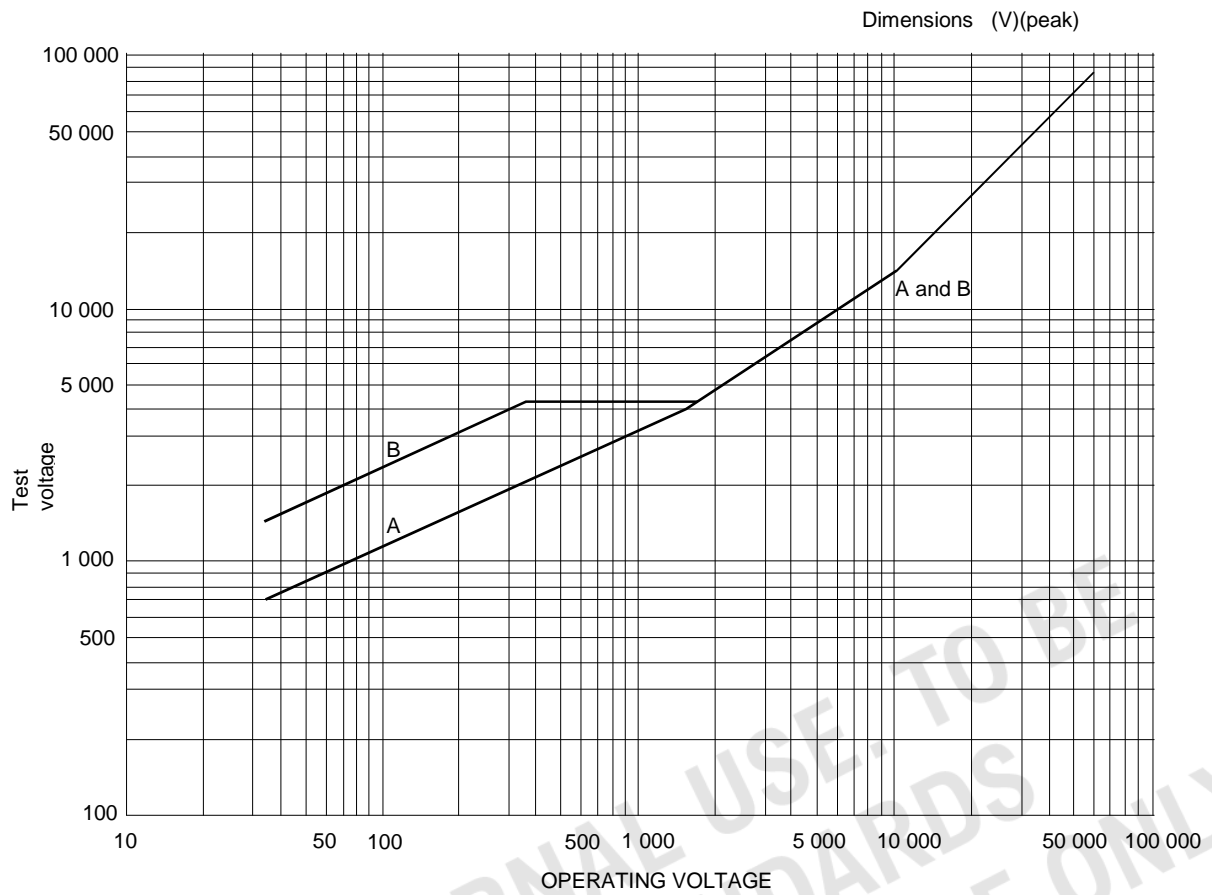

NOTE See 10.4.2 and Table 5.

Figure 7 – Test voltages

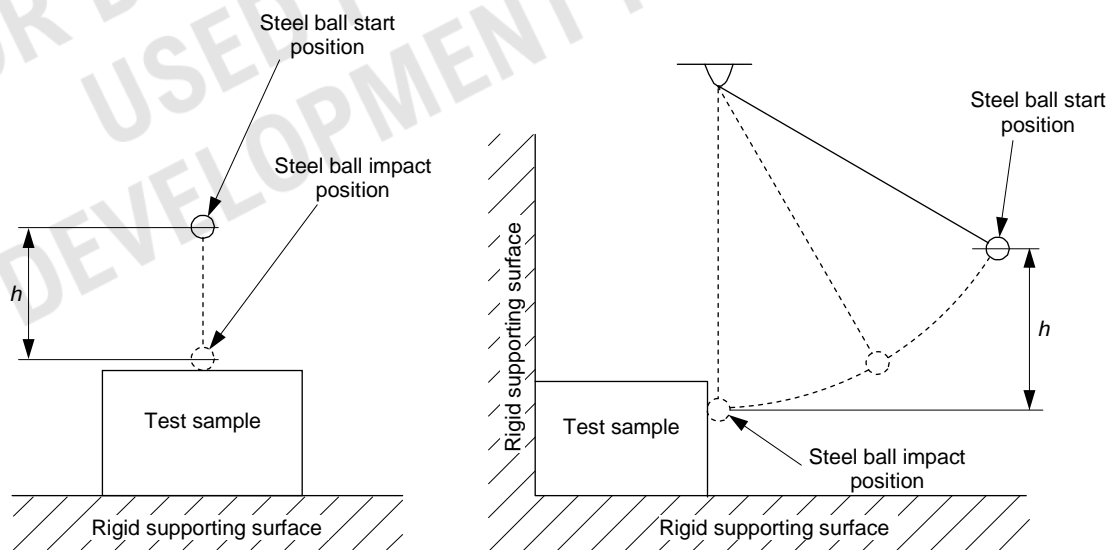

NOTE See 12.1.4.

Figure 8 – Impact test using a steel ball

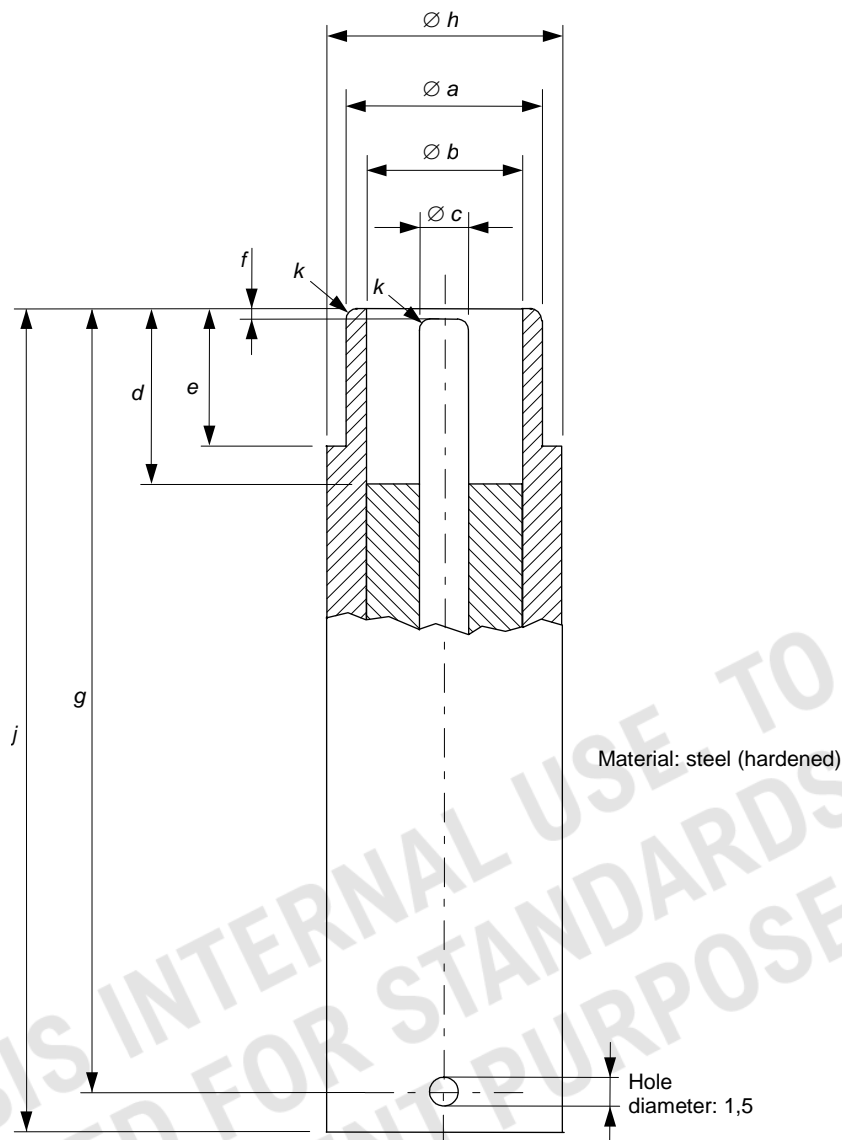

Dimensions in millimetres

<i>a</i>	<i>b</i> min.	<i>c</i>	<i>d</i> min.	<i>e</i> min.	<i>f</i>	<i>g</i>	<i>h</i>	<i>j</i>	<i>k</i> min.
9,576 <sup>0</sup> <sub>-0,1</sub>	8,05	2,438 <sup>0</sup> <sub>-0,1</sub>	9,1	7,112	0,8 ± 0,4	40 ± 0,4	12 ± 0,4	43 ± 0,4	0,3 radii

The mating section of the test plug is in accordance with IEC 60169-2, Figure 7.

NOTE See 12.5.

**Figure 9 – Test plug for mechanical tests on antenna coaxial sockets**

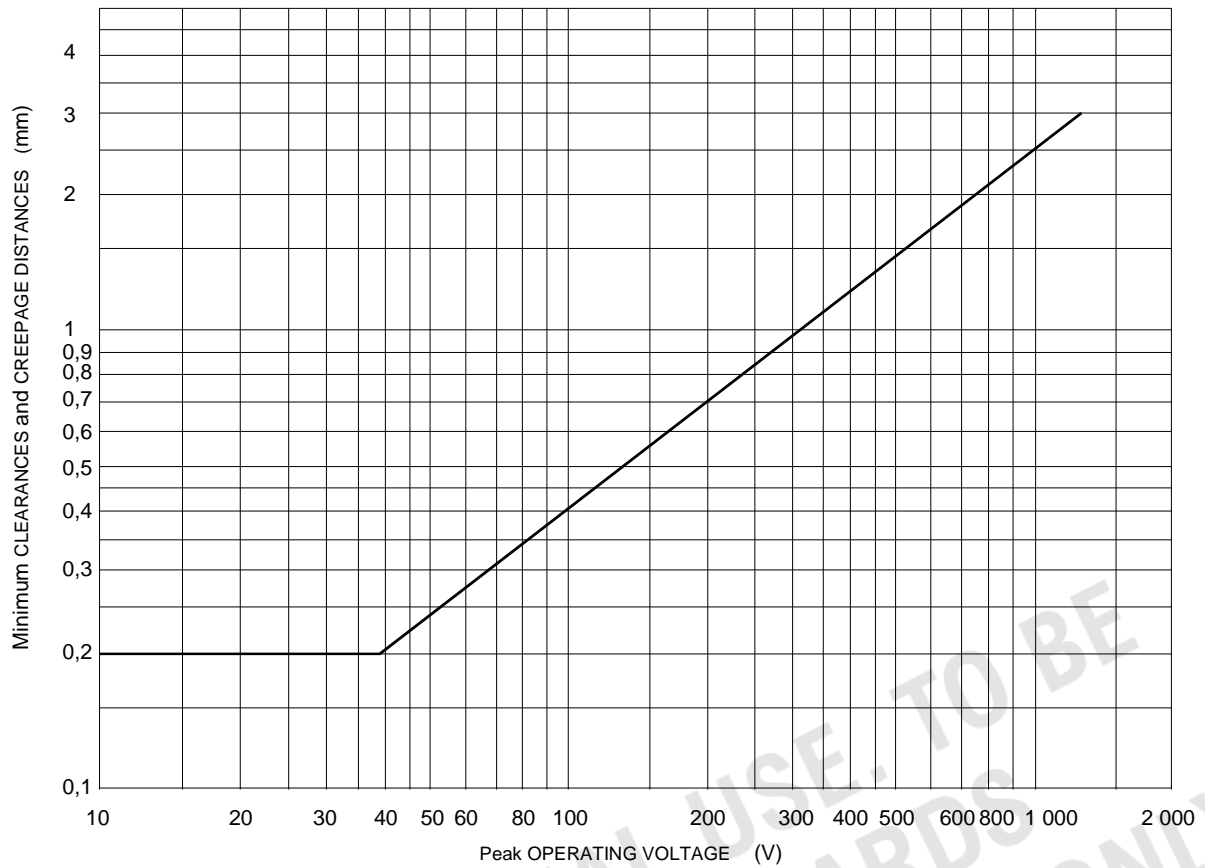

The curve is defined by the formula:

$$\log d = 0,78 \log (U/300)$$

with a minimum of 0,2 mm

where

$d$  is the distance;

$U$  is the peak voltage (V).

NOTE See 13.5.1.

**Figure 10 – Minimum CLEARANCES and CREEPAGE DISTANCES on PRINTED BOARDS**

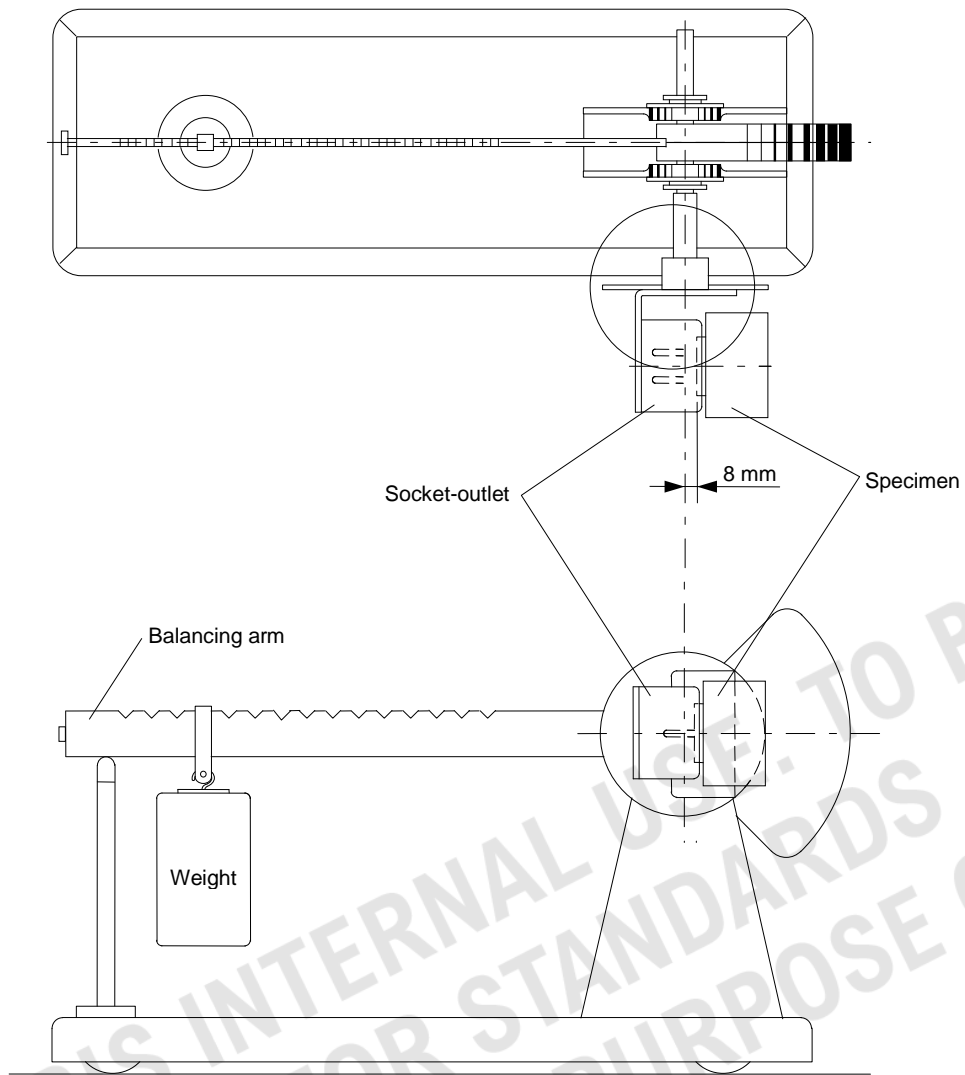

NOTE See 15.4.1.

**Figure 11 – Test apparatus for devices forming a part of the MAINS plug**

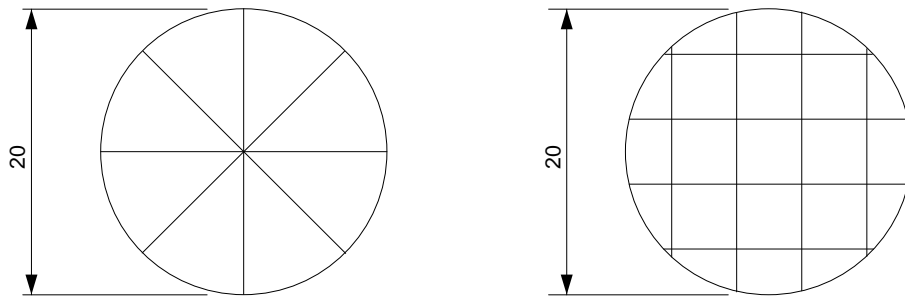

*Dimensions in millimetres*

NOTE See 18.2.

**Figure 12 – Scratch patterns for implosion test**

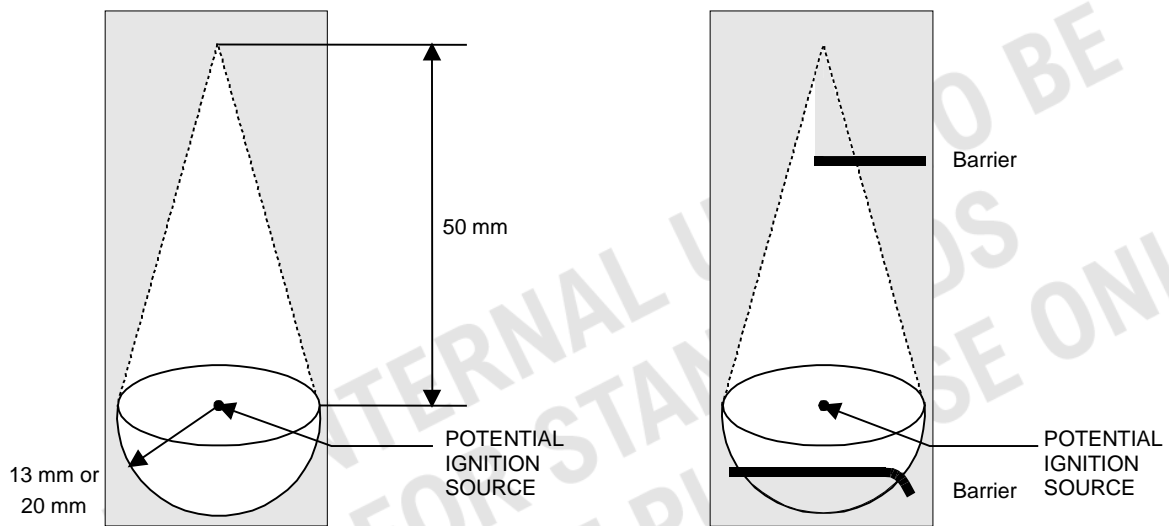

NOTE 1 In the shaded areas, the requirements of 20.2.5 but not covered by Table 21, apply.

NOTE 2 See 20.2.5

**Figure 13 – Distances from a POTENTIAL IGNITION SOURCE and an example for the design of barriers**

Dimensions in millimeters

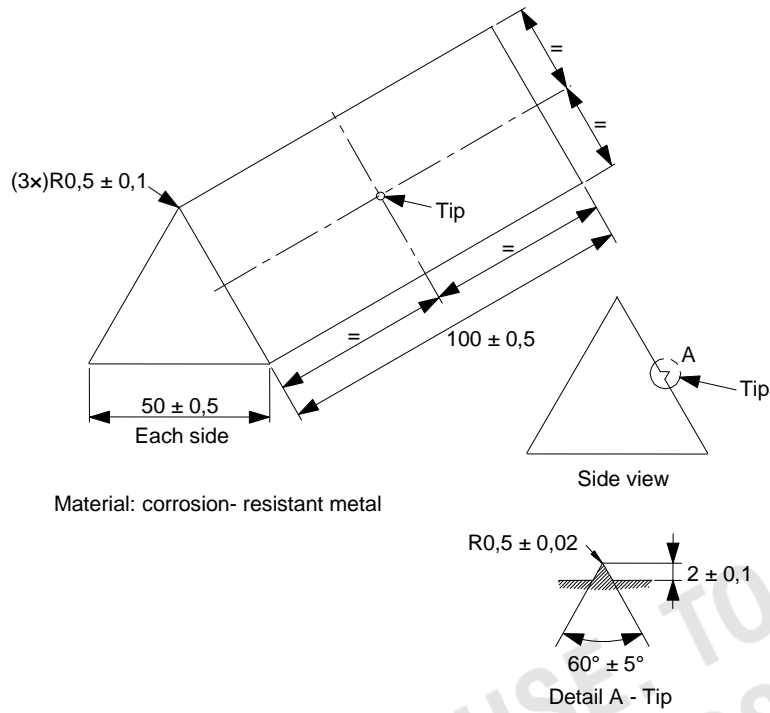

Figure 14 – Mandrel

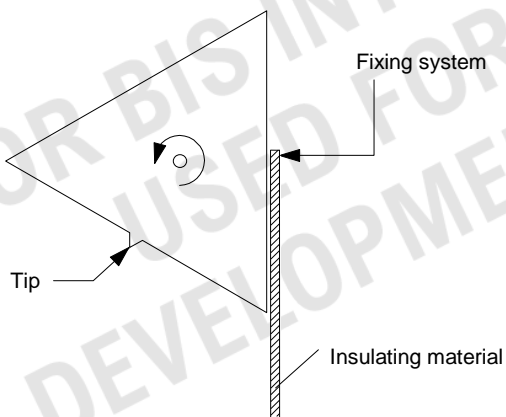

Figure 15 – Initial position of mandrel

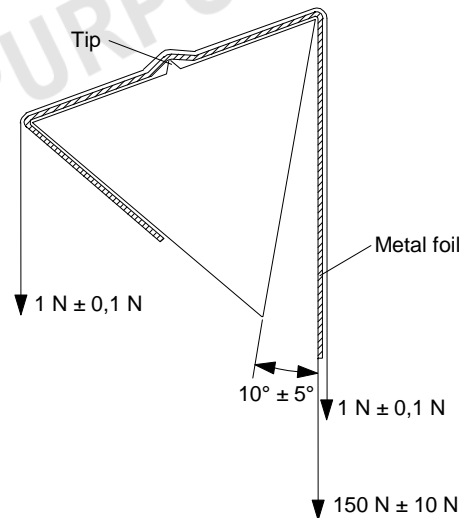
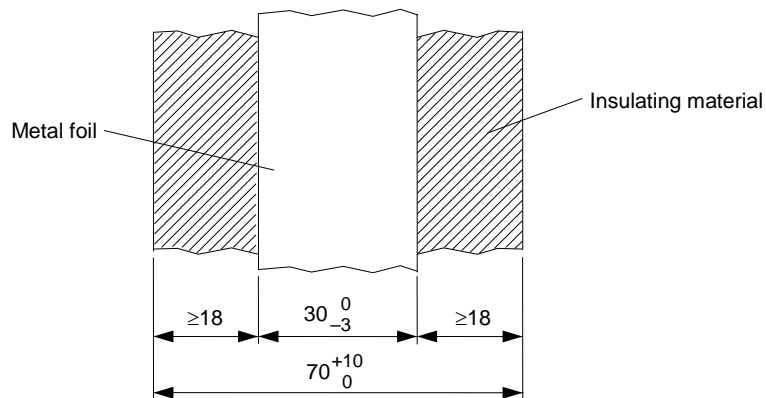

Figure 16 – Final position of mandrel

The final position of the mandrel is rotated  $230^\circ \pm 5^\circ$  from the initial position.

Dimensions in millimeters



NOTE 1 Figure 17 is slightly modified compared to Figure 6c of IEC 61558-1:2005.

Figures 15 and 16 are slightly modified compared to Figure 6b from IEC 61558-1:2005.

NOTE 2 See 8.21.

**Figure 17 – Position of metal foil on insulating material**

FOR BIS INTERNAL USE TO BE  
USED FOR STANDARDS  
DEVELOPMENT PURPOSE ONLY

**Annex A**  
(normative)

**Additional requirements for apparatus  
with protection against splashing water**

NOTE The clause numbering of this annex refers to the clauses of this standard

**A. 1 General**

The requirements of this standard, supplemented or replaced by those contained in this annex, apply to apparatus provided with protection against splashing water.

**A.5 Marking and instructions**

*Add the following item after 5.2 h):*

A.5.2 i) *Protection against splashing water*

Apparatus provided with protection against splashing water shall be marked at least with the designation IPX4 in accordance with IEC 60529.

*Compliance is checked by inspection.*

A.5.5.2 a) *Subclause 5.5.2 a) does not apply.*

**A.10 Insulation requirements**

*Modify 10.3 as follows:*

**A.10.3 Splash and humidity treatment**

**A.10.3.1 Splash treatment**

The enclosure shall provide adequate protection against splashing water.

*Compliance is checked by the treatment specified below, which is made on the apparatus fitted with external flexible cords in accordance with the requirements of Clause 16.*

*The apparatus is subjected to the test described in 14.2.4 a) of IEC 60529:1989.*

*Immediately after this treatment, the apparatus shall comply with the tests of 10.4 and inspection shall show that water, which may have entered the apparatus, does not cause any damage in the sense of this standard; in particular, there shall be no trace of water on insulations for which CREEPAGE DISTANCES are specified.*

**A.10.3.2 Humidity treatment**

*Subclause 10.3 applies, except that the duration of the test is seven days (168 h).*

**Annex B**  
(normative)

**Apparatus to be connected to the  
TELECOMMUNICATION NETWORKS**

The requirements of this standard supplemented by the requirements of IEC 62151 as referenced in this annex apply to apparatus within the scope of this standard intended to be connected to TELECOMMUNICATION NETWORKS.

NOTE 1 In countries listed in IEC 62151, special national conditions apply.

NOTE 2 Attention is drawn to the fact that the telecommunication authorities can impose additional requirements on apparatus to be connected to TELECOMMUNICATION NETWORKS. Those requirements generally concern the protection of the networks as well as the USERS of the apparatus.

IEC 62151:2000 Clause 1, except for 1.4, and Clause 2 apply.

IEC 62151:2000 Clause 3 applies, with the following modification:

*Replace 3.5.4 by the definition 2.4.10 of this standard.*

IEC 62151:2000 Clause 4 applies, with the exception of 4.1.2, 4.1.3 and 4.2.1.2.

*The requirements of 4.1.2 shall be replaced by the following requirements:*

In a single TNV-0 CIRCUIT or in interconnected TNV-0 CIRCUITS, the voltage between any two conductors of the TNV-0 CIRCUIT or CIRCUITS and, between any one such conductor and earth shall not exceed the values given in 9.1.1.2 of this standard.

NOTE 3 A circuit that meets the above requirements, but that is subject to overvoltages from a TELECOMMUNICATION NETWORK, is a TNV-1 CIRCUIT.

*The requirements of 4.1.3 shall be replaced by the following requirements:*

In the event of a single failure of BASIC INSULATION or SUPPLEMENTARY INSULATION, or of a component (excluding components with DOUBLE or REINFORCED INSULATION), the voltages between any two conductors of the TNV-0 CIRCUIT or CIRCUITS and between any one such conductor and earth shall not exceed the values given in 9.1.1.2 of this standard for more than 0,2 s. Moreover, the limit values as given in 11.1 shall not be exceeded.

Except as permitted in 4.1.4, one of the methods specified in 4.1.3.1, 4.1.3.2, or 4.1.3.3 shall be used.

Parts of the interface circuit that do not comply with the requirements for TNV-0 CIRCUITS under normal operating conditions shall therefore not be USER ACCESSIBLE.

*The requirements of 4.2.1.2 shall be replaced by the following requirements:*

NOTE 4 See also Clauses 5 and 6.

Separation of TNV-0 CIRCUITS, TNV-1 CIRCUITS and ACCESSIBLE conductive parts from TNV-2 CIRCUITS and TNV-3 CIRCUITS shall be such that

- under normal operating conditions, the limits specified in 4.2.1.1 a) for TNV-1 CIRCUITS (35 V peak, or 60 V d.c.) are not exceeded on the TNV-0 CIRCUITS, TNV-1 CIRCUITS and ACCESSIBLE conductive parts.

- in the event of a single insulation fault, the limits specified in 4.2.1.1 b) for TNV-2 CIRCUITS and TNV-3 CIRCUITS under normal operating conditions (70 V peak, or 120 V d.c.) are not exceeded on the TNV-0 CIRCUITS, TNV-1 CIRCUITS and ACCESSIBLE conductive parts. However, after 0,2 s the voltage limits of 4.1.2 (35 V peak, or 60 V d.c.) shall apply.

The separation requirements will be met if BASIC INSULATION is provided as indicated in Table B.1, which also shows where 6.1 applies; other solutions are not excluded.

**Table B.1 – Separation of TNV circuits**

Parts being separated		Separation
TNV-0 CIRCUIT or ACCESSIBLE conductive parts	TNV-1 CIRCUIT	6.1
	TNV-2 CIRCUIT	BASIC INSULATION
	TNV-3 CIRCUIT	BASIC INSULATION and 6.1
TNV-1 CIRCUIT	TNV-2 CIRCUIT	BASIC INSULATION and 6.1
TNV-2 CIRCUIT	TNV-3 CIRCUIT	6.1
TNV-1 CIRCUIT	TNV-3 CIRCUIT	BASIC INSULATION
TNV-1 CIRCUIT	TNV-1 CIRCUIT	functional insulation
TNV-2 CIRCUIT	TNV-2 CIRCUIT	functional insulation
TNV-3 CIRCUIT	TNV-3 CIRCUIT	functional insulation

BASIC INSULATION is not required provided that all of the following are met:

- the TNV-0 CIRCUIT, TNV-1 CIRCUIT or ACCESSIBLE conductive part shall be connected to a PROTECTIVE EARTHING TERMINAL in accordance with this standard; and
- the installation instructions specify that the PROTECTIVE EARTHING TERMINAL shall be permanently connected to earth; and
- the test of 4.2.1.5 shall be carried out if the TNV-2 or TNV-3 CIRCUIT is intended to receive signals or power that are generated externally during normal operation (for example in a TELECOMMUNICATION NETWORK).

At the choice of the manufacturer, it is permitted to treat a TNV-1 CIRCUIT or a TNV-2 CIRCUIT as a TNV-3 CIRCUIT. In this case, the TNV-1 CIRCUIT or TNV-2 CIRCUIT shall meet all the separation requirements for a TNV-3 CIRCUIT.

*Compliance is checked by inspection and measurement and, where necessary, by simulation of failures of components and insulations such as are likely to occur in the apparatus. Prior to the tests, insulation that does not meet the requirements for BASIC INSULATION is short-circuited.*

NOTE 5 Where BASIC INSULATION is provided and 6.1 also applies to this insulation, the test voltage prescribed in 6.2 is in most cases higher than that for BASIC INSULATION.

*Clause 5 of IEC 62151 applies, with the following modification in 5.3.1:*

The value 1,6 shall be replaced by the value 1,8.

*Clauses 6 and 7 of IEC 62151 apply.*

Annex A up to and including Annex C of IEC 62151 apply.

**Annex C**  
(normative)

**Band-pass filter for wide-band noise measurement**

For wide-band measurement see 6.1 of IEC 60268-1:1985.

The filter shall be a band-pass filter having a frequency response within the limits shown in Figure C.1.

A band-pass filter which has a substantially constant transmission factor between 22,4 Hz and 22,4 kHz, decreasing outside this frequency band at the rates specified for octave-band filters having mid-band frequencies of 31,5 Hz and 16 000 Hz specified in IEC 61260, has a response falling within the limits of this specification.

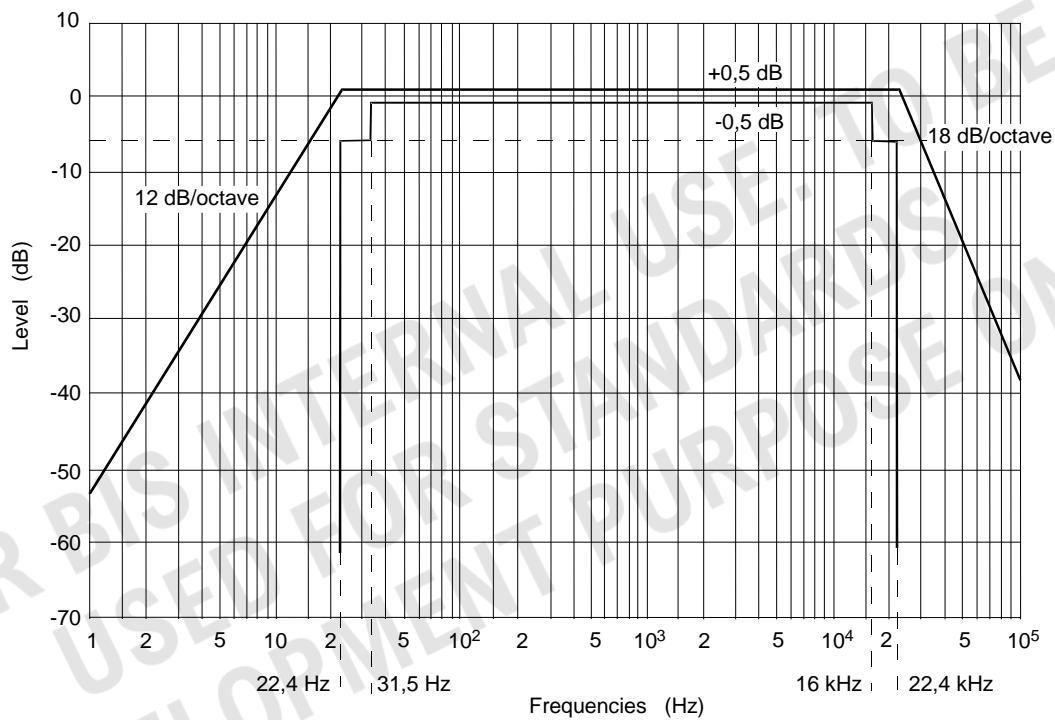

Source: Figure 5 of IEC 60268-1:1985.

NOTE 1 Strong signals just above or below the band-limits can, to some degree, influence the individual frequency response of the filter actually used.

NOTE 2 See 4.1.6.

**Figure C.1 – Band-pass filter for wide-band noise measurement  
(amplitude/frequency response limits)**

**Annex D**  
(normative)

**Measuring network for TOUCH CURRENTS**

Figure D.1 below shows the measuring network for TOUCH CURRENTS according to IEC 60990.

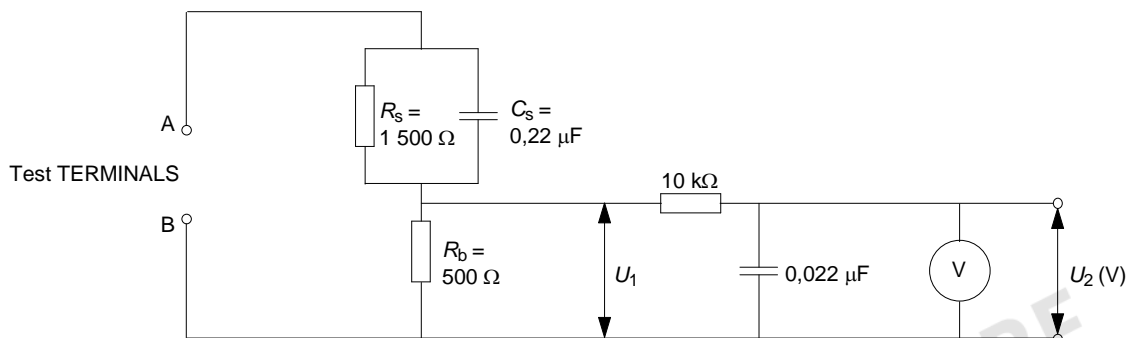

Resistance values in ohms ( $\Omega$ )

V: Voltmeter or oscilloscope (r.m.s. or peak reading)

Input resistance:  $\geq 1 \text{ M}\Omega$

Input capacitance:  $\leq 200 \text{ pF}$

Frequency range: 15 Hz to 1 MHz and d.c. respectively

Appropriate measures should be taken to obtain the correct value in case of non-sinusoidal waveforms.

The measuring instrument is calibrated by comparing the frequency factor of  $U_2$  with the solid line in Figure F.2 of IEC 60990 at various frequencies. A calibration curve is constructed showing the deviation of  $U_2$  from the ideal curve as a function of frequency.

TOUCH CURRENT =  $U_2/500$  (peak value).

NOTE See 9.1.1.2.

**Figure D.1 – Measuring network for TOUCH CURRENTS according to IEC 60990**

**Annex E**  
(normative)

**Measurement of CLEARANCES and CREEPAGE DISTANCES**

The methods of measuring CLEARANCES and CREEPAGE DISTANCES which are specified in the following figures are used in interpreting the requirements of this standard.

In the following figures, the value of  $X$  is given in Table E.1. Where the distance shown is less than  $X$ , the depth of the gap or groove is disregarded when measuring a CREEPAGE DISTANCE.

Table E.1 is valid only if the required minimum CLEARANCE is 3 mm or more. If the required minimum CLEARANCE is less than 3 mm, the value  $X$  is the lesser of:

- the relevant value in Table E.1, or
- one-third of the required minimum CLEARANCE.

**Table E.1 – Value of  $X$**

Pollution degree (see 13.1)	$X$ mm
1	0,25
2	1,0
3	1,5

In Figures E.1 to E.10, CLEARANCES and CREEPAGE DISTANCES are shown as follows:

■■■■■■ CREEPAGE DISTANCE      ————— CLEARANCE

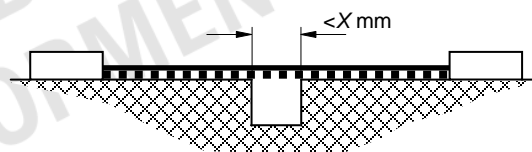

Condition: Path under consideration includes a parallel or converging-sided groove of any depth with width less than  $X$  mm.

Rule: CLEARANCE and CREEPAGE DISTANCE are measured directly across the groove.

**Figure E.1 – Narrow groove**

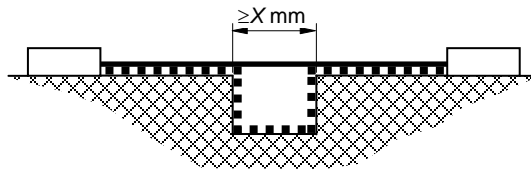

Condition: Path under consideration includes a parallel-sided groove of any depth, and equal to or more than X mm wide.

Rule: CLEARANCE is the "line-of-sight" distance, CREEPAGE DISTANCE path follows the contour of the groove.

Figure E.2 – Wide groove

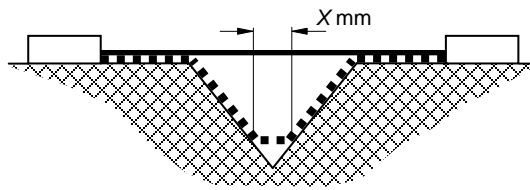

Condition: Path under consideration includes a V-shaped groove with internal angle of less than 80° and a width greater than X mm.

Rule: CLEARANCE is the "line-of-sight" distance. CREEPAGE DISTANCE path follows the contour of the groove but "short-circuits" the bottom of the groove by a link X mm long.

Figure E.3 – V-shaped groove

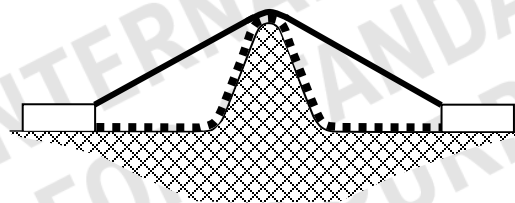

Condition: Path under consideration includes a rib.

Rule: CLEARANCE is the shortest direct air path over the top of the rib. CREEPAGE DISTANCE path follows the contour of the rib.

Figure E.4 – Rib

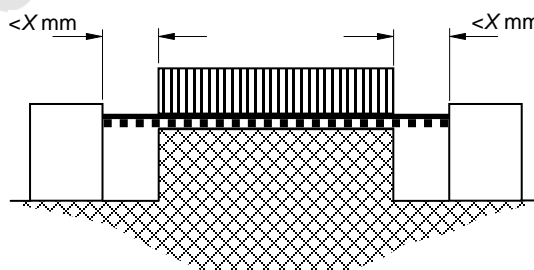

Condition: Path under consideration includes an uncemented joint with grooves less than X mm wide on either side.

Rule: CREEPAGE DISTANCE and CLEARANCE path is the "line-of-sight" distance shown.

Figure E.5 – Uncemented joint with narrow groove

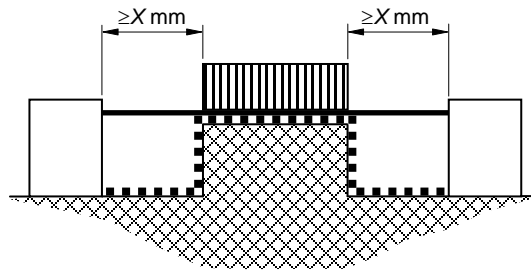

Condition: Path under consideration includes an uncemented joint with a groove equal to or more than X mm wide each side.

Rule: CLEARANCE is the "line-of-sight" distance. CREEPAGE DISTANCE path follows the contour of the groove.

**Figure E.6 – Uncemented joint with wide groove**

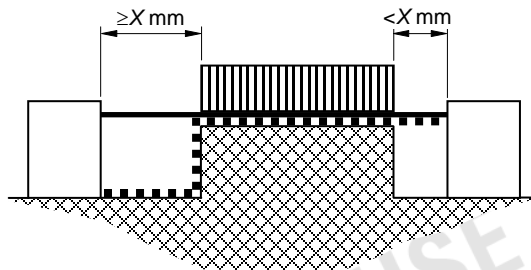

Condition: Path under consideration includes an uncemented joint with a groove on one side less than X mm wide and a groove on the other equal to or more than X mm wide.

Rule: CLEARANCE and CREEPAGE DISTANCE paths are as shown in Figure E.7.

**Figure E.7 – Uncemented joint with narrow and wide grooves**

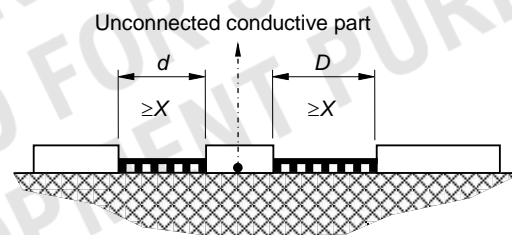

Condition: Insulation distance with intervening, unconnected conductive part.

Rule: CLEARANCE is the distance  $d + D$ , CREEPAGE DISTANCE is also  $d + D$ . Where the value of  $d$  or  $D$  is smaller than  $X$  it shall be considered as zero.

**Figure E.8 – Intervening, unconnected conductive part**

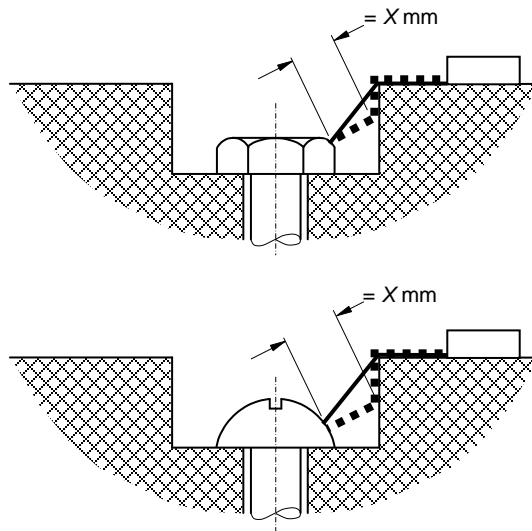

Gap between head of screw and wall of recess too narrow to be taken into account.  
Measurement of CREEPAGE DISTANCE is from screw to wall where the distance is equal to X mm.

**Figure E.9 – Narrow recess**

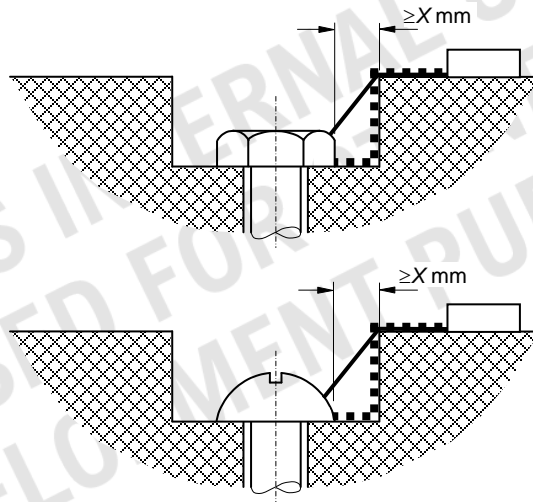

Gap between head of screw and wall of recess wide enough to be taken into account.

**Figure E.10 – Wide recess**

**Annex F**  
(normative)

**Table of electrochemical potentials**

FOR BIS INTERNAL USE. TO BE  
USED FOR STANDARDS  
DEVELOPMENT PURPOSE ONLY

## Annex G (normative)

### Flammability test methods

**G.1** If no test specimens in accordance with Clause 7 of IEC 60695-11-10:2013 are available, the following test methods may be applied.

The test is made according to IEC 60695-11-5 on three specimens of end products as used in the apparatus.

For the purpose of this standard, the following applies with regard to IEC 60695-11-5:

#### Clause 9 – Test procedure

##### – Subclause 9.1

This subclause is replaced by the following:

The test specimens are mounted in such a way as to simulate the conditions obtained when installed in the apparatus.

##### – Subclause 9.2

Replace the second paragraph by the following:

The test flame is applied to several points of the specimen, so that all critical areas are tested.

#### Clause 10 – Observations and measurements.

The second paragraph is replaced by the following:

Duration of the burning denotes the time interval from the moment the test flame is removed until any flame has been extinguished.

**G.1.1** If flammability category V-0 according to IEC 60695-11-10 is required, in addition, the following applies with regard to IEC 60695-11-5.

#### Clause 7 – Severities

The values of duration of application of the test flame are as follows:

The test flame is applied for 10 s. If a self-sustaining flame does not last longer than 15 s, the test flame is applied again for 1 min at the same point or at any other point. If again a self-sustaining flame does not last longer than 15 s, the test flame is then applied for 2 min at the same point or at any other point.

#### Clause 11 – Evaluation of test results

The existing text is replaced by the following:

After the first application of the test flame, the test specimens shall not be consumed completely. After any application of the test flame, the duration of the burning of any specimen shall not exceed 15 s, while the average burning time shall not exceed 10 s. The tissue paper shall not ignite and the board shall not scorch.

**G.1.2** If flammability category V-1 according to IEC 60695-11-10 is required, in addition, the following applies with regard to IEC 60695-11-5.

#### Clause 7 – Severities

The values of duration of application of the test flame are as follows:

The test flame is applied for 10 s. If a self-sustaining flame does not last longer than 30 s, the test flame is applied again for 1 min at the same point or at any other point. If again a

*self-sustaining flame does not last longer than 30 s, the test flame is then applied for 2 min at the same point or at any other point.*

*Clause 8 – Preconditioning (only applicable to components of 14.5.2)*

*The existing text is replaced by:*

*The specimens are stored for 2 h in an oven at a temperature of  $(100 \pm 2)$  °C.*

*Clause 11 – Evaluation of test results*

*The existing text is replaced by the following:*

*After the first application of the test flame, the test specimen shall not be consumed completely. After any application of the test flame, any self-sustaining flame shall extinguish within 30 s. No burning of the tissue paper shall occur and the board shall not scorch.*

**G.1.3** *If flammability category V-2 according to IEC 60695-11-10 is required, in addition, the following applies with regard to IEC 60695-11-5.*

*Clause 7 – Severities*

*The values of duration of application of the test flame are as follows:*

*The test flame is applied for 10 s. If a self-sustaining flame does not last longer than 30 s, the test flame is applied again for 1 min at the same point or at any other point. If again a self-sustaining flame does not last longer than 30 s, the test flame is then applied for 2 min at the same point or at any other point.*

*Clause 11 – Evaluation of test results*

*The existing text is replaced by the following:*

*After the first application of the test flame, the test specimen shall not be consumed completely.*

*After any application of the test flame, any self-sustaining flame shall extinguish within 30 s.*

**G.1.4** *If flammability category HB75 or HB40 according to IEC 60695-11-10 is required, the following applies with regard to IEC 60695-11-10.*

*Three specimens,  $125 \text{ mm} \pm 5 \text{ mm}$  in length by  $13 \text{ mm} \pm 0,5 \text{ mm}$  in width, cut from the thinnest part to be tested, are subjected to the burning test as described in IEC 60695-11-10:2013, Clause 8, Test method A.*

*The material shall be classified HB75 or HB40 respectively as described in 8.4 of IEC 60695-11-10.*

**G.2** *Compliance of cables and insulation of wires is checked according to IEC 60695-11-5.*

*For the purpose of this standard, the following applies with regard to IEC 60695-11-5.*

*Clause 7 – Severities*

*The values of duration of the application of the test flame are as follows:*

- first specimen: 10 s*
- second specimen: 60 s*
- third specimen: 120 s*

*Clause 9 – Test procedure*

- Subclause 9.2*

*Replace the fourth paragraph by the following:*

*The burner is supported so that its axis is in an angle of 45° to the vertical. The cable or wire is held in an angle of 45° to the vertical, its axis being in a vertical plane perpendicular to the vertical plane containing the axis of the burner.*

- Subclause 9.3 is replaced by the following:

*The test is made on three specimens taken from each type of cable or wire as used in the apparatus, for example with additional screening and sleeves.*

#### Clause 10 – Observations and measurements

*The second paragraph is replaced by the following:*

*Duration of the burning denotes the time interval from the moment the test flame is removed until any flame has extinguished.*

#### Clause 11 – Evaluation of the results

*The existing text is replaced by the following:*

*During the test, any burning of the insulating materials shall be steady and shall not spread appreciably. Any flame shall self-extinguish in 30 s from the removal of the test flame.*

- G.3** A barrier shall comply with the following requirements.

*Three specimens are subjected to the following tests:*

- 1) *In case of a non-metallic barrier, each test specimen is fixed horizontally and a needle flame as specified in IEC 60695-11-5 is applied from below with an angle of 45°.*

*The top of the flame shall be:*

- a) *applied to the barrier as used in the appliance, at a location likely to become ignited because of its actual proximity and distance to the POTENTIAL IGNITION SOURCE*

*or*

- b) *applied to a sample plate with the same thickness and made of the same material, touching the undersurface of this sample plate in the middle.*

*The flame shall be applied for 60 s in the same position.*

*The needle flame shall not penetrate the test specimen and after the application there shall be no hole in the test specimen.*

*No failure is allowed.*

- 2) *In case of openings in a barrier regardless of its material, the requirements shown in Figure 13 apply, unless it is not possible for the needle flame as specified in IEC 60695-11-5 to penetrate the barrier.*

*Compliance is tested according to 1) above. After the test there shall be no change with regard to the openings in the barrier. No failure is allowed.*

## Annex H (normative)

### Insulated winding wires for use without interleaved insulation (see 8.16)

#### H.1 General

The annex specifies winding wires whose insulation may be used to provide BASIC INSULATION, SUPPLEMENTARY INSULATION, DOUBLE INSULATION or REINFORCED INSULATION in wound components without interleaved insulation.

This annex covers round winding wires having diameters between 0,05 mm and 5,0 mm.

#### H.2 Type tests

##### H.2.1 General

*The wire shall pass the following TYPE TESTS, carried out at a temperature between 15 °C and 35 °C and a relative humidity between 45 % and 75 %, unless otherwise specified.*

##### H.2.2 Dielectric strength

*The test sample is prepared according to 4.4.1 of IEC 60851-5:2008 (for a twisted pair). The sample is then subjected to the relevant test of 10.4 of this standard, without the humidity treatment of 10.3, with a test voltage not less than twice the appropriate voltage in Table 5 of this standard, with a minimum of*

- 6 kV r.m.s. or 8,4 kV (peak) for REINFORCED INSULATION, or
- 3 kV r.m.s. or 4,2 kV (peak) for BASIC INSULATION or SUPPLEMENTARY INSULATION.

##### H.2.3 Flexibility and adherence

*Test 8 of 5.1.1 of IEC 60851-3:2009, using the mandrel diameters of Table H.1 of this standard.*

*The test sample is then examined in accordance with 5.1.1.4 of IEC 60851-3:2009, followed by the relevant test of 10.4 of this standard, without the humidity treatment of 10.3, except that the test voltage is applied between the wire and the mandrel. The test voltage shall be not less than the appropriate voltage in Table 5 of this standard, with a minimum of*

- 3 kV r.m.s. or 4,2 kV (peak) for REINFORCED INSULATION, or
- 1,5 kV r.m.s. or 2,1 kV (peak) for BASIC INSULATION or SUPPLEMENTARY INSULATION.

**Table H.1 – Mandrel diameter**

Nominal conductor diameter mm	Mandrel diameter mm ± 0,2 mm
0,05 to 0,34	4,0
0,35 to 0,49	6,0
0,50 to 0,74	8,0
0,75 to 2,49	10,0
2,50 to 5,00	4 times the conductor diameter <sup>a</sup>
<sup>a</sup> In accordance with IEC 60317-43.	

The tension to be applied to the wire during winding on the mandrel is calculated from the wire diameter to be equivalent to  $118 \text{ MPa} \pm 10 \%$  ( $118 \text{ N/mm}^2 \pm 10 \%$ )

#### H.2.4 Heat shock

Test 9 of IEC 60851-6:2012, followed by the dielectric strength test of Table 5 of this standard except that the test voltage is applied between the wire and the mandrel. The test voltage shall be not less than the appropriate voltage in Table 5 of this standard, with a minimum of

- 3 kV r.m.s. or 4,2 kV (peak) for REINFORCED INSULATION, or
- 1,5 kV r.m.s or 2,1 kV (peak) for BASIC INSULATION or SUPPLEMENTARY INSULATION.

The oven temperature is the relevant temperature of the thermal class of insulation in Table H. 2.

The mandrel diameter and tension applied to the wire during winding on the mandrel are as in H.2.3.

The dielectric strength test is conducted at room temperature after removal from the oven.

Table H.2 – Oven temperature

Thermal class	A (105)	E (120)	B (130)	F (155)	H (180)
Oven temperature $^{\circ}\text{C} \pm 5 \text{ }^{\circ}\text{C}$	200	215	225	240	260

#### H.2.5 Retention of dielectric strength after bending

Five samples are prepared as in H.2.2 and tested as follows. Each sample is removed from the mandrel, placed in a container and positioned so that it can be surrounded by at least 5 mm of metal shot. The ends of the conductor in the sample shall be sufficiently long to avoid flash-over. The shot shall be not more than 2 mm in diameter and shall consist of balls of stainless steel, nickel or nickel plated iron. The shot is gently poured into the container until the sample under test is covered by at least 5 mm of shot. The shot shall be cleaned periodically with a suitable solvent (for example 1,1,1-trichloroethane).

The test voltage shall be not less than the appropriate voltage in Table 5 of this standard, with a minimum of

- 3 kV r.m.s. or 4,2 kV (peak) for REINFORCED INSULATION, or
- 1,5 kV r.m.s or 2,1 kV (peak) for BASIC INSULATION or SUPPLEMENTARY INSULATION.

The test voltage is applied between the shot and the conductor.

### H.3 Testing during manufacture

#### H.3.1 General

The wire shall be subjected by the wire manufacturer to dielectric strength tests during manufacture as specified in H.3.2 and H.3.3.

#### H.3.2 ROUTINE TEST

The test voltage for ROUTINE TEST shall be the appropriate voltage in Table 5 of this standard, with a minimum of

- 3 kV r.m.s. or 4,2 kV (peak) for REINFORCED INSULATION, or
- 1,5 kV r.m.s. or 2,1 kV (peak) for BASIC INSULATION or SUPPLEMENTARY INSULATION.

### **H.3.3 Sampling test**

*Twisted pair samples shall be tested in accordance with 4.4.1 of IEC 60851-5:2008. The test voltage shall be twice the appropriate voltage in Table 5 of this standard, but not less than*

- 6 kV r.m.s. or 8,4 kV (peak) for REINFORCED INSULATION, or
- 3 kV r.m.s. or 4,2 kV (peak) for BASIC INSULATION or SUPPLEMENTARY INSULATION.

FOR BIS INTERNAL USE. TO BE  
USED FOR STANDARDS  
DEVELOPMENT PURPOSE ONLY

**Annex I  
(Void)**

FOR BIS INTERNAL USE. TO BE  
USED FOR STANDARDS  
DEVELOPMENT PURPOSE ONLY

## Annex J (normative)

### Alternative method for determining minimum CLEARANCES

#### J.1 General

This annex contains the alternative method for determining minimum CLEARANCES referred to in 13.3.

There is no dielectric strength test to verify CLEARANCES.

#### J.2 Summary of the procedure for determining minimum CLEARANCES

NOTE The minimum CLEARANCES for BASIC, SUPPLEMENTARY and REINFORCED INSULATION, whether in a primary circuit or another circuit, depend on the REQUIRED WITHSTAND VOLTAGE. The REQUIRED WITHSTAND VOLTAGE depends in turn on the combined effect of the normal WORKING VOLTAGE (including repetitive peaks due to internal circuitry such as switch mode power supplies) and non-repetitive overvoltages due to external transients.

To determine the minimum value for each required CLEARANCE, the following steps shall be used.

- a) Measure the peak WORKING VOLTAGE across the CLEARANCE in question.
- b) If the apparatus is MAINS operated:
  - determine the MAINS transient voltage (see Clause J.3); and
  - calculate the peak value of the nominal a.c. MAINS voltage.
- c) Use the rules in Clause J.5 a) and the above voltage values to determine the REQUIRED WITHSTAND VOLTAGE for a.c. MAINS supply transients and internal transients. In the absence of transients coming from a TELECOMMUNICATION NETWORK, go to step g).
- d) If the apparatus is to be connected to a TELECOMMUNICATION NETWORK, determine the TELECOMMUNICATION NETWORK TRANSIENT VOLTAGE (see Clause J.4).
- e) Use the TELECOMMUNICATION NETWORK TRANSIENT VOLTAGE and the rules in Clause J.5 b) to determine the REQUIRED WITHSTAND VOLTAGE for TELECOMMUNICATION NETWORK transients. In the absence of MAINS and internal transients, go to step g).
- f) Use the rules in Clause J.5 c) to determine the total REQUIRED WITHSTAND VOLTAGE.
- g) Use the REQUIRED WITHSTAND VOLTAGE to determine the minimum CLEARANCE (see Clause J.7).

#### J.3 Determination of MAINS transient voltage

For apparatus to be supplied from the a.c. MAINS supply, the value of the MAINS transient voltage depends on the overvoltage category and the nominal value of the a.c. MAINS voltage. In general, CLEARANCES in apparatus intended to be connected to the a.c. MAINS supply shall be designed for a MAINS transient voltage in overvoltage category II.

The applicable value of the MAINS transient voltage shall be determined from the overvoltage category and the nominal a.c. MAINS voltage using Table J.1.

Table J.1 – MAINS transient voltages

Nominal a.c. MAINS voltage line-to-neutral  Up to and including  V r.m.s.	MAINS transient voltage  V (peak)	
	Overvoltage category	
	I	II
50	330	500
100	500	800
150 <sup>a</sup>	800	1 500
300 <sup>b</sup>	1 500	2 500
600 <sup>c</sup>	2 500	4 000
NOTE 1 In Norway, due to the IT power distribution system used, the a.c. MAINS voltage is considered to be equal to the line-to-line voltage, and will remain 230 V in case of a single earth fault.		
NOTE 2 In Japan, the MAINS transient voltage for the nominal 100 V system should be selected from the 150 V line of the table.		
<sup>a</sup> Including 120/208 V or 120/240 V		
<sup>b</sup> Including 230/400 V or 277/480 V		
<sup>c</sup> Including 400/690 V		

#### J.4 Determination of TELECOMMUNICATION NETWORK TRANSIENT VOLTAGE

If the TELECOMMUNICATION NETWORK TRANSIENT VOLTAGE is not known for the TELECOMMUNICATION NETWORK in question, it shall be taken as:

- 1 500 V<sub>peak</sub> if the circuit connected to the TELECOMMUNICATION NETWORK is a TNV-1 CIRCUIT or a TNV-3 CIRCUIT; and
- 800 V<sub>peak</sub> if the circuit connected to the TELECOMMUNICATION NETWORK is a TNV-0 CIRCUIT or a TNV-2 CIRCUIT.

#### J.5 Determination of REQUIRED WITHSTAND VOLTAGE

##### a) MAINS and internal transients

- circuit CONDUCTIVELY CONNECTED TO THE MAINS receiving the unattenuated MAINS transient:

In such a circuit, the effect of transients coming from a TELECOMMUNICATION NETWORK is ignored, and the following rules shall be applied:

Rule 1) If the peak WORKING VOLTAGE  $U_{po}$  is less than the peak value of the nominal a.c. MAINS supply voltage, the REQUIRED WITHSTAND VOLTAGE is the MAINS transient voltage determined in Clause J.3;

$$U_{\text{REQUIRED WITHSTAND}} = U_{\text{MAINS transient}}$$

Rule 2) If the peak WORKING VOLTAGE  $U_{po}$  is greater than the peak value of the nominal a.c. MAINS voltage, the REQUIRED WITHSTAND VOLTAGE is the MAINS transient voltage determined in Clause J.3, plus the difference between the peak WORKING VOLTAGE and the peak value of the nominal a.c. MAINS voltage from Table J.1.

$$U_{\text{REQUIRED WITHSTAND}} = U_{\text{MAINS transient}} + U_{po} - U_{\text{MAINS peak}}$$

- circuit not CONDUCTIVELY CONNECTED TO THE MAINS whose supply circuit is CONDUCTIVELY CONNECTED TO THE MAINS receives the unattenuated MAINS transient:

In such a circuit, the REQUIRED WITHSTAND VOLTAGE shall be determined as follows, ignoring the effect of transients coming from TELECOMMUNICATION NETWORKS.

The above rules 1) and 2) are applied, with the MAINS transient voltage determined in Clause J.3 replaced by a voltage that is one step smaller in the following list:

330, 500, 800, 1 500, 2 500 and 4 000  $V_{\text{peak}}$ .

However, this reduction is not permitted for a floating circuit not CONDUCTIVELY CONNECTED TO THE MAINS unless it is in apparatus with a PROTECTIVE EARTHING TERMINAL and is separated from its circuit CONDUCTIVELY CONNECTED TO THE MAINS by an earthed metal screen, connected to protective earth in accordance with 15.2.

Alternatively, the above rules 1) and 2) are applied but the voltage determined by measurement, see Clause J.6 a), is taken as the MAINS transient voltage.

- circuits CONDUCTIVELY CONNECTED TO THE MAINS and circuits not CONDUCTIVELY CONNECTED TO THE MAINS not receiving the unattenuated MAINS transient:

In such circuits, the REQUIRED WITHSTAND VOLTAGE, ignoring the effect of transients coming from any TELECOMMUNICATION NETWORK, is determined as follows. The above rules 1) and 2) are applied, but a voltage determined by measurement, see Clause J.6 a), shall be taken as the MAINS transient voltage.

- circuits not CONDUCTIVELY CONNECTED TO THE MAINS supplied by a d.c. source having capacitive filtering:

In any earthed circuit not CONDUCTIVELY CONNECTED TO THE MAINS supplied by a d.c. source with capacitive filtering, the REQUIRED WITHSTAND VOLTAGE shall be taken as equal to the d.c. voltage.

b) TELECOMMUNICATION NETWORK transients

If only transients from a TELECOMMUNICATION NETWORK are involved, the REQUIRED WITHSTAND VOLTAGE is the TELECOMMUNICATION NETWORK TRANSIENT VOLTAGE determined in Clause J.4, unless a lower level is measured when tested according to Clause J.6 b).

c) Combination of transients

If both transients a) and b) are involved, the REQUIRED WITHSTAND VOLTAGE is the larger of the two voltages. The two values shall not be added together.

## **J.6 Measurement of transient levels**

The following tests are conducted only where it is required to determine whether or not transient voltage across the CLEARANCE in any circuit is lower than normal, due for example, to the effect of a filter in the apparatus. The transient voltage across the CLEARANCE is measured using the following test procedure.

*During the tests, the apparatus is connected to its separate SUPPLY APPARATUS, if any, but is not connected to the MAINS, nor to any TELECOMMUNICATION NETWORK, and any surge suppressors in circuits CONDUCTIVELY CONNECTED TO THE MAINS are disconnected.*

*A voltage-measuring device is connected across the CLEARANCE in question.*

- a) *To measure the reduced level of transients due to MAINS overvoltages, the impulse test generator of Annex K is used to generate 1,2/50  $\mu\text{s}$  impulses, with  $U_c$  equal to the MAINS transient voltage determined in J.3.*

*Three to six impulses of alternating polarity, with intervals of at least 1 s between impulses, are applied between each of the following points where relevant:*

- *line-to-line;*
- *all line conductors conductively joined together and neutral;*
- *all line conductors conductively joined together and protective earth; and*
- *neutral and protective earth.*

b) To measure the reduced level of transients due to TELECOMMUNICATION NETWORK overvoltages, the impulse test generator of Annex K is used to generate 10/700  $\mu$ s impulses, with  $U_c$  equal to the TELECOMMUNICATION NETWORK TRANSIENT VOLTAGE determined in J.4.

Three to six impulses of alternating polarity, with intervals of at least 1 s between impulses, are applied between each of the following TELECOMMUNICATION NETWORK connection points of a single interface type:

- each pair of TERMINALS (for example A and B or tip and ring) in an interface; and
- all TERMINALS of a single interface type joined together and earth.

Only one of a set of identical circuits is tested.

### J.7 Determination of minimum CLEARANCES

Each CLEARANCE shall comply with the minimum dimensions given in Table J.2, using the value of REQUIRED WITHSTAND VOLTAGE determined according to Clause J.5.

The specified CLEARANCES are not applicable to the air gap between the contacts of thermostats, THERMAL CUT-OUTS, overload protection devices, switches of microgap construction and similar components where the air gap varies with the contacts.

NOTE For air gaps between the contacts of disconnect devices, see 8.18.

For apparatus to be operated at more than 2 000 m above sea level, Table A.2 of IEC 60664-1:2007 should be used in addition to Table J.2.

Table J.2 – Minimum CLEARANCES

CLEARANCES in millimetres

REQUIRED WITHSTAND VOLTAGE  V peak or d.c.	Minimum CLEARANCES in air	
	BASIC and SUPPLEMENTARY INSULATION	REINFORCED INSULATION
up to 400	0,2 (0,1)	0,4 (0,2)
800	0,2 (0,1)	0,4 (0,2)
1 000	0,3 (0,2)	0,6 (0,4)
1 200	0,4 (0,3)	0,8 (0,6)
1 500	0,8 (0,5)	1,6 (1)
2 000	1,3 (1)	2,6 (2)
2 500	2 (1,5)	4 (3)
3 000	2,6 (2)	5,2 (4)
4 000	4 (3)	6
6 000	7,5	11
8 000	11	16
10 000	15	22
12 000	19	28
15 000	24	36
25 000	44	66
40 000	80	120
50 000	100	150
60 000	120	180
80 000	173	260
100 000	227	340

Except in circuits CONDUCTIVELY CONNECTED TO THE MAINS in Clause J.5 a), linear interpolation is permitted between the nearest two points, the calculated minimum CLEARANCES being rounded up to the next higher 0,1 mm increment.

The values in parentheses are applicable only if manufacturing is subjected to a quality control programme, (an example for such a programme is given in Annex M). In particular, DOUBLE and REINFORCED INSULATION shall be subjected to ROUTINE TESTS for dielectric strength.

Compliance with a CLEARANCE value of 8,4 mm or greater for circuits not CONDUCTIVELY CONNECTED TO THE MAINS is not required if the CLEARANCE path is

- entirely through air; or
- wholly or partly along the surface of an insulation of material group I (CTI.600);

and the insulation involved passes a dielectric strength test according to 10.4, using

- an a.c. test voltage whose r.m.s. value is equal to 1,06 times the peak WORKING VOLTAGE; or
- a d.c. test voltage equal to the peak value of the a.c. test voltage prescribed above.

If the CLEARANCE path is partly along the surface of a material that is not material group I, the dielectric strength test is conducted across the air gap only.

Compliance is checked by measurement, taking into account Annex E.

The following conditions are applicable.

Movable parts are placed in their most unfavourable positions.

When measuring CLEARANCES from an enclosure of insulating material through a slot or opening in the enclosure, the ACCESSIBLE surface is considered to be conductive as if it were covered by metal foil wherever it can be touched by the test finger, according to test probe B of IEC 61032:1997 (see 9.1.1), applied without appreciable force (see Figure 3, point B).

When measuring CLEARANCES, the test forces of 13.3.1 are to be applied.

**Annex K**  
(normative)

**Impulse test generators**  
(see 13.3.4 and Annex J, Clause J.6)

The circuit in Figure K.1, using the component values in Table K.1, is used to generate impulses, the  $C_1$  capacitor being charged initially to a voltage  $U_c$ .

The impulse test circuits are based on ITU-T Recommendation K.44

The impulse wave shapes are under open-circuit conditions and can be different under load conditions.

NOTE Extreme care is necessary when using these generators due to the high electric charge stored in capacitor  $C_1$ .

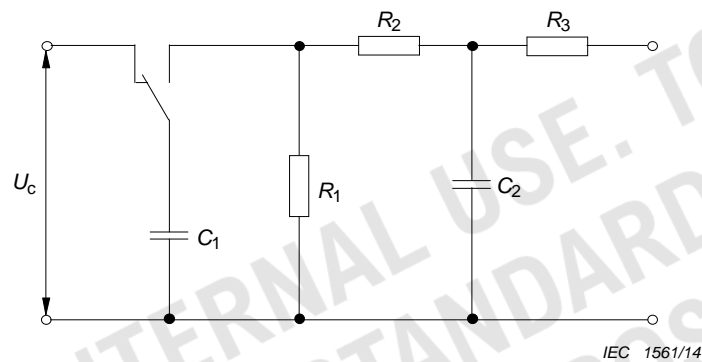

Figure K.1 – Impulse generating circuit

Table K.1 – Component values for impulse generating circuits

Test impulse	$C_1$	$R_1$	$R_2$	$C_2$	$R_3$
10/700 $\mu$ s	20 $\mu$ F	50 $\Omega$	15 $\Omega$	0,2 $\mu$ F	25 $\Omega$
1,2/50 $\mu$ s	1 $\mu$ F	76 $\Omega$	13 $\Omega$	33 nF	25 $\Omega$

## Annex L (normative)

### Additional requirements for electronic flash apparatus for photographic purposes

#### L.1 Overview

The requirements of this standard, supplemented or replaced by those contained in this annex, apply to electronic flash apparatus for photographic purposes.

NOTE 1 This annex replaces IEC 60491:1984.

NOTE 2 The clause numbering of this annex refers to the clauses of this standard.

#### L.2 General

*Add the following to 1.1.1:*

**L.1.1.1** This annex applies to the following electronic flash apparatus for photographic purposes, having a stored energy not exceeding 2 000 J, together with associated apparatus and not intended to be subjected to dripping or splashing:

- apparatus of the single-flash type which can have more than one flash head operating at the same time;
- apparatus for the illumination of sequential photographic exposures;
- battery chargers and SUPPLY APPARATUS to be used in connection with electronic flash apparatus for photographic purposes. These auxiliary units may form a part of the MAINS plug;
- accessories specified in the instruction leaflet.

This annex does not apply to stroboscopes.

As long as no appropriate requirements exist for apparatus having a stored energy exceeding 2 000 J, this annex may be used, in so far as it is applicable. Additional requirements may be necessary, for example, for explosion and thermal radiation.

This annex is intended to cover apparatus which can be used both in moderate and tropical climates.

For the modeling lamps combined with electronic flash apparatus for photographic purposes, additional requirements may be taken from IEC 60598-2-9 or IEC 60598-2-17, as far as applicable.

#### L.4 General test conditions

*Add the following subclauses after 4.2.13:*

**L.4.2.14** *The apparatus is tested with or without connection of flash heads, capacitors and other accessories.*

**L.4.2.15** *If the apparatus can be MAINS-operated, it is switched on for a period of 4 h without flashing; if only battery or rechargeable battery is supplied, it is switched on for 30 s.*

*Thereupon as many consecutive flashes as can be produced, with a maximum of 40, are made as quickly as possible. The rate of flashing is determined by the indicator or, if no indicator, by the measured voltage on the flash capacitors, which should be 85 % of the maximum peak voltage. The apparatus is supplied at its RATED SUPPLY VOLTAGE.*

*A battery charger is connected for 4 h to a fully discharged rechargeable battery for which the charger has been designed.*

*Add the following dashed items to 4.3.4:*

#### **L.4.3.4**

- *interruption of filaments of lamps;*
- *short and open circuiting of glow-discharge lamps (used for indication or regulation).*

*Add the following item to 4.3.5:*

#### **L.4.3.5**

- g) self-healing capacitors (for example, of the metallized paper type) as far as overheating is concerned.*

### **L.5 Marking and instructions**

*Add the following at the end of 5.5.1:*

**L.5.5.1** Battery chargers and SUPPLY APPARATUS shall be accompanied by an instruction leaflet in which shall be indicated the type or model number of flash apparatus with which they are to be used.

The flash apparatus shall be accompanied by an instruction leaflet in which shall be indicated the type or model number of SUPPLY APPARATUS or battery charger with which it is to be used.

Alternatively, this information may be given on the apparatus itself.

*Compliance is checked by inspection.*

### **L.7 Heating under normal operating conditions**

*Add the following to 7.1.6 after the first paragraph:*

**L.7.1.6** Lithium batteries shall meet the permissible temperature rise in Table 3, "Normal operating conditions", unless such batteries comply with the applicable electrical tests of IEC 60086-4.

### **L.9 Electric shock hazard under normal operating conditions**

*Add the following to 9.1.1.1 after the second paragraph:*

**L.9.1.1.1** TERMINALS for the connection to the synchronizer of the camera shall not be HAZARDOUS LIVE.

*Add the following to 9.1.1.2 after the first paragraph:*

L.9.1.1.2 *If possible, flashing is made during the measurements.*

## L.10 Insulation requirements

*Add the following to 10.4.2 directly before Table 5:*

**L.10.4.2** *In the case of apparatus with high frequency pulse ignition, the ignition pulse is ignored in computing the test voltage if the duration of the pulse does not exceed 1 ms.*

## L.11 Fault conditions

*Add the following to 11.2.8 after the first paragraph:*

**L.11.3.8** Lithium batteries shall meet the permissible temperature rise in Table 3, "Fault conditions", unless such batteries comply with all electrical tests of IEC 60086-4.

## L.12 Mechanical strength

*Add the following after the fourth paragraph of 12.1.4:*

**L.12.1.4** *Windows for flash tubes are excluded from the steel ball impact test.*

## L.14 Components

*Add the following subclause at the end of 14.7:*

**L.14.7.6** Furthermore, for MAINS SWITCHES, the characteristics of the switch, with reference to the marking, shall be appropriate for the function of the switch in the apparatus under normal conditions.

*Compliance is checked by inspection and by measurement.*

*The rated MAINS current of a flash apparatus is determined by the following formula:*

$$I_r = 1/3 \sqrt{\hat{i}_0^2 + \hat{i}_0 \hat{i}_1 + \hat{i}_1^2}$$

where

$\hat{i}_0$  *is the maximum MAINS current (peak value) immediately after a flash has been made.*

$\hat{i}_1$  *is the MAINS current (peak value) at the end of the re-charge period of the flash capacitor. The end of the re-charge period is determined by the indicator or, if there is no indicator, by the measured voltage on the flash capacitor, which shall be 85 % of the maximum peak voltage, the apparatus supplied at its RATED SUPPLY VOLTAGE.*

*The apparatus is operated under normal operating conditions except that the apparatus is connected to its RATED SUPPLY VOLTAGE.*

$\hat{i}_0$  and  $\hat{i}_1$  *are measured when the apparatus is ready for flash operation and has been connected to the MAINS supply for at least 30 min.*

*The peak surge current is the maximum peak value of the MAINS current when the flash apparatus is switched on, after the flash capacitor has been discharged completely. Current spikes up to 100  $\mu$ s duration are disregarded.*

*The measured peak surge current and calculated rated MAINS current ( $I_r$ ) shall not exceed the marked current rating of the MAINS SWITCH.*

**L.20 Resistance to fire**

*Add the following to 20.2.1:*

**L.20.2.1**

- c) A trigger coil circuit for discharge purposes in a flash apparatus is not considered to be a POTENTIAL IGNITION SOURCE.

FOR BIS INTERNAL USE. TO BE  
USED FOR STANDARDS  
DEVELOPMENT PURPOSE ONLY

**Annex M**  
(informative)

**Examples of requirements for quality control programmes  
for allowing reduced clearances**

NOTE This annex gives examples of requirements for quality control programmes as specified in 13.3 and Annex J for reduced CLEARANCES.

A manufacturer wishing to use reduced CLEARANCES permitted by 13.3 and Annex J should implement a quality control programme for those features of the construction listed in Table M.1. This programme should include specific quality controls for the tools and materials that affect CLEARANCES.

The manufacturer should also identify and plan the protection and, where applicable, installation processes which directly affect quality and should ensure that these processes are carried out under controlled conditions. Controlled conditions should include the following:

- documented work instructions defining process, apparatus, environment, and manner of production where the absence of such instructions would adversely affect quality, suitable working environment, compliance with reference standards or specifications and quality plans;
- monitoring and control of suitable processes and product characteristics during production and installation in the apparatus;
- criteria for workmanship stipulated to the extent necessary in written specifications or by means of representative samples; and
- records maintained for qualified processes, apparatus and personnel as appropriate.

Table M.1 provides the sampling plan for attributes and tests necessary to conform to the requirements of 13.3 and Annex J. The number of samples of production parts or assemblies should be based on IEC 60410 or ISO 2859-1 or equivalent national standards.

**Table M.1 – Rules for sampling and inspection – Reduced CLEARANCES**

Tests	BASIC INSULATION	SUPPLEMENTARY INSULATION	REINFORCED INSULATION
CLEARANCE <sup>a</sup>	Sampling S2 AQL 4	Sampling S2 AQL 4	Sampling S2 AQL 4
Dielectric strength test <sup>b</sup>	No test	No test	ROUTINE TEST one failure requires evaluation for cause
<p><sup>a</sup> To minimise test and inspection time, it is permitted to replace measurement of CLEARANCES by measurement of breakdown voltage. Initially the breakdown voltage is established for ten samples for which the correct CLEARANCE measurements have been confirmed. The breakdown voltage of subsequent parts or assemblies is then checked against a lower limit equal to the minimum breakdown voltage of the initial ten samples minus 100 V. If breakdown occurs at this lower limit, a part or assembly is considered a failure unless direct measurement of the CLEARANCE conforms to the requirement.</p> <p><sup>b</sup> The dielectric strength test for REINFORCED INSULATION should consist of one of the following alternatives:</p> <ul style="list-style-type: none"> <li>– six impulses of alternating polarity, using a 1,2/50 µs impulse (see Annex K) with a magnitude equal to the peak of the test voltage in Table 5 (see 10.4.2); or</li> <li>– a three cycle pulse of a.c. power frequency with a magnitude equal to the test voltage in Table 5 (see 10.4.2); or</li> <li>– six impulses of alternating polarity, using 10 ms d.c. impulses with a magnitude equal to the peak of the test voltage in Table 5 (see 10.4.2).</li> </ul>			

## Annex N (informative)

### Routine tests

#### N.1 General

The tests given in this annex are intended to reveal, as far as safety is concerned, unacceptable variations in material or manufacture. These tests do not impair the properties and the reliability of the apparatus, and should be made by the manufacturer on each apparatus during or at the end of the production.

In general, more tests, such as repetition of TYPE TESTS and sampling tests, have to be made by the manufacturer to ensure that every apparatus is in conformity with the sample that withstood the TYPE TEST of this standard, according to experience gained by the apparatus manufacturer.

The manufacturer may use a test procedure which is better suited to his production arrangements and may make the tests at an appropriate stage during production, provided it can be proved that apparatus which withstand the tests carried out by the manufacturer provide at least the same degree of safety as apparatus that withstand the tests specified in this annex.

NOTE Generally, an appropriate quality assurance system is employed, for example according to the ISO 9000 series.

The rules in Annex N are given as an example for ROUTINE TEST.

#### N.2 Tests during the production process

##### N.2.1 Correct polarity and connection of components or subassemblies

If incorrect polarity or connection of components or subassemblies might result in a safety hazard, the correct polarity and connection of these components or subassemblies should be checked by measurement or inspection.

##### N.2.2 Correct values of components

If incorrect values of components might result in a safety hazard, the correct value of these components should be checked by measurement or inspection.

##### N.2.3 Protective earthing connection of screens and metal barriers

For CLASS I apparatus with a screen or metal barrier (see 8.5) between HAZARDOUS LIVE parts and TERMINALS regarded as ACCESSIBLE (see 8.4) or ACCESSIBLE conductive parts respectively, the continuity of the protective earthing connection should be checked as late as possible during the production process between the screen or metal barrier and

- the protective earthing contact of the MAINS plug or appliance inlet, or
- the PROTECTIVE EARTHING TERMINAL in case of a PERMANENTLY CONNECTED APPARATUS.

The test current applied for 1 s to 4 s should be in the order of 10 A a.c., derived from a source having a no-load voltage not exceeding 12 V.

The measured resistance should not exceed

- 0,1  $\Omega$  for apparatus with a detachable power supply cord, or

- 0,2  $\Omega$  for apparatus with a non-detachable power supply cord.

Care should be taken that the contact resistance between the tip of the measuring probe and the metal parts under test does not influence the test results.

#### **N.2.4 Correct position of internal wiring**

If incorrect position of internal wiring might impair the safety, the correct position of internal wiring should be checked by inspection.

#### **N.2.5 Correct fit of internal plug connections**

If incorrect fit of internal plug connections might impair the safety, the correct fit of internal plug connections should be checked by inspection or manual test.

#### **N.2.6 Safety relevant markings inside the apparatus**

The legibility of markings relevant to safety inside the apparatus, for example with regard to fuses, should be checked by inspection.

#### **N.2.7 Correct mounting of mechanical parts**

If incorrect mounting of mechanical parts might impair the safety, the correct mounting should be checked by inspection or manual test.

### **N.3 Tests at the end of the production process**

#### **N.3.1 General**

The following tests should be made on the apparatus when completely assembled and just before packing.

#### **N.3.2 Dielectric strength test**

The insulation of the apparatus should be checked by the following tests. In general, these tests are considered to be sufficient.

An a.c. test voltage of substantially sine-wave form, having MAINS frequency, or a d.c. test voltage or a combination of both with a peak value specified in Table N.1, is applied between the MAINS supply TERMINALS connected in parallel and:

- TERMINALS regarded as ACCESSIBLE (see 8.4), and
- ACCESSIBLE conductive parts respectively,

which may become HAZARDOUS LIVE in the event of an insulation fault as a result of incorrect assembly.

TERMINALS regarded as ACCESSIBLE and ACCESSIBLE conductive parts may be connected together during the dielectric strength test.

**Table N.1 – Test voltage**

Application of test voltage	Test voltage V (peak) a.c. or d.c.	
	Rated MAINS voltage ≤150	Rated MAINS voltage >150
BASIC INSULATION	1 130 (800 r.m.s.)	2 120 (1 500 r.m.s.)
DOUBLE or REINFORCED INSULATION	2 120 (1 500 r.m.s.)	3 540 (2 500 r.m.s.)

Before the test voltage is applied, intimate contact should be made with the specimen.

Initially, not more than half of the prescribed test voltage is applied, then it is raised with a steepness not exceeding 1 560 V/ms to the full value which is held for 1 s to 4 s.

NOTE A steepness of 1 560 V/ms corresponds to the steepness of a sine-wave with a MAINS frequency of 60 Hz.

During the test, MAINS SWITCHES and functional switches, if any, CONDUCTIVELY CONNECTED TO THE MAINS, should be in the on-position and it should be secured by suitable means so that the test voltage is completely effective.

No flash-over or breakdown should occur during the test. The test voltage source should be provided with a current sensing (over-current) device which, when activated, gives an indication that the test has been failed. The test voltage source should still deliver the prescribed voltage until current tripping occurs.

Tripping of the current sensing device is regarded as a flashover or breakdown.

### **N.3.3 Protective earthing connection**

For CLASS I apparatus, the continuity of the protective earthing connection should be checked between the protective earthing contact of the MAINS plug or appliance inlet, or the PROTECTIVE EARTHING TERMINAL in case of a PERMANENTLY CONNECTED APPARATUS, and

- the ACCESSIBLE conductive parts, including TERMINALS regarded as ACCESSIBLE (see 8.4), which should be connected to the PROTECTIVE EARTHING TERMINAL, and
- the protective earthing contact of socket-outlets respectively, if provided to deliver power to other apparatus.

The test current applied for 1 s to 4 s should be in the order of 10 A a.c., derived from a source having a no-load voltage not exceeding 12 V.

The measured resistance should not exceed:

- 0,1 Ω for apparatus with a detachable power supply cord, or
- 0,2 Ω for apparatus with a non-detachable power supply cord.

Care should be taken that the contact resistance between the tip of the measuring probe and the conductive parts under test does not influence the test results.

### **N.3.4 Safety relevant markings on the outside of the apparatus**

The legibility of safety relevant markings on the outside of the apparatus, for example with regard to the supply voltage, should be checked by inspection.

## Bibliography

IEC 60130-2, *Connectors for frequencies below 3 MHz – Part 2: Connectors for radio receivers and associated sound equipment*

IEC 60130-9, *Connectors for frequencies below 3 MHz – Part 9: Circular connectors for radio and associated sound equipment*

IEC 60169-2, *Radio-frequency connectors – Part 2: Coaxial unmatched connector*

IEC 60169-3, *Radio-frequency connectors – Part 3: Two-pin connector for twin balanced aerial feeders*

IEC 60320-2-2:1998, *Appliance couplers for household and similar general purposes – Part 2-2: Interconnection couplers for household and similar equipment*

IEC 60335-2-56, *Safety of household and similar electrical appliances – Part 2: Particular requirements for projectors and similar appliances*

IEC 60335-2-82, *Safety of household and similar electrical appliances – Part 2: Particular requirements for service machines and amusement machines*

IEC 60598-2-9:1987, *Luminaires – Part 2: Particular requirements – Section 9: Photo and film luminaires (non-professional)*  
Amendment 1:1993

IEC 60598-2-17:1984, *Luminaires – Part 2: Particular requirements – Section 17: Luminaires for stage lighting, television and film studios (outdoor and indoor)*  
Amendment 2:1990

IEC 60664-4, *Insulation coordination for equipment within low-voltage systems – Part 4: Consideration of high-frequency stress*

IEC 60695 (all parts), *Fire hazard testing*

IEC 60728-11, *Cable networks for television signals, sound signals and interactive services - Part 11: Safety*

IEC 60884-1, *Plugs and socket-outlets for household and similar purposes – Part 1: General requirements*

IEC 60906-1:2009, *IEC system of plugs and socket-outlets for household and similar purposes – Part 1: Plugs and socket-outlets 16 A 250 V a.c.*

IEC 61558-2-1, *Safety of power transformers, power supply units and similar – Part 2: Particular requirements for separating transformers for general use*

IEC 61558-2-4, *Safety of power transformers, power supply units and similar – Part 2: Particular requirements for isolating transformers for general use*

IEC 61558-2-6, *Safety of power transformers, power supply units and similar – Part 2: Particular requirements for safety isolating transformers for general use*

IEC 62087, *Methods of measurement for the power consumption of audio, video and related equipment*

ISO/IEC Guide 37:1995, *Instructions for use of products of consumer interest*

ISO/IEC Guide 51:1999, *Safety aspects – Guidelines for their inclusion in standards*

ISO 1043-1, *Plastics – Symbols and abbreviated terms – Part 1: Basic polymers and their special characteristics*

ISO 9000 (all parts), *Quality management and quality assurance standards*

ICRP 15:1969, *Protection against ionizing radiations from external sources*. International Commission on Radiological Protection

---

FOR BIS INTERNAL USE. TO BE  
USED FOR STANDARDS  
DEVELOPMENT PURPOSE ONLY



